

- ▲ Dyna-Tube Extrusion, aerodynamic radius corner shape, high strength — low weight.
- ▲ Offset design to accommodate the new style exhaust systems.
- ▲ 4" Foot assembly provides increased trailer clearance, easier mounting and durability.

- ▲ New T-Beam extrusion provides for a better weight to strength ratio, for improved load resistance. This allows Merritt to decrease T-beam profile by one inch, allowing greater swing room clearance.
- ▲ Seven Mounting Kits available.

- ▲ 5" uprights require less mounting space and give unparalleled load resistance.
- ▲ Great for storage, one door, two door and full three door enclosures are available. Internal shelves and chain hangers are popular options. Keep your storage items out of the weather and out of sight.

## LIMITED SECURITY RACK (LSR)



Dyna-Light LSR - Pictured W/328 Kit



Diamond Back LSR



Offset LSR

**OPTIONS AVAILABLE - ADD TO YOUR LSR BASE UNIT** (SEE PAGE 1B FOR DETAILS)



Jail Bar Window  
22"W x 25"H  
Order #367 Weight 6



E-Z View Window  
26 5/8"W x 22 3/16"H  
Order #369



E-Z View Full Window  
Order #386



Grab Handle, 25"  
Order #142 Weight 1



Top Mount Light Bar, 14" Pad  
Order #141-1 Weight 7



Top Mount Light Bar, 51.5" Pad  
Order #141-2 Weight 19



Beacon Bracket, Fixed  
Order #393 Weight 2

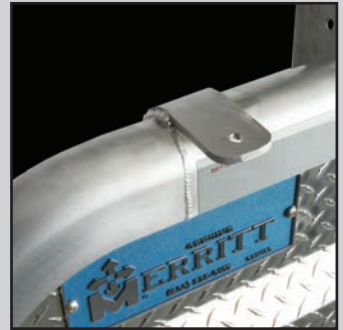

Bracket, Load Light  
Order #144 Weight 1

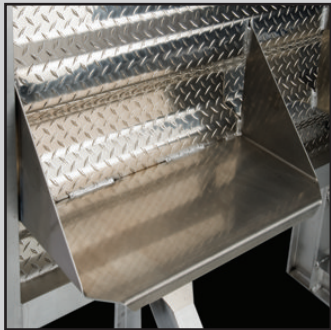

Tray Panel Mount 12" x 26"  
Order #326 Weight 8



20 3/4" x 30 1/2" Base Tray  
Order #337 Weight 9



20" x 24" x 24" Tuck-Away Box  
Order #230 Weight 47



Stop & Turn Light Bracket  
Order #145-1 Weight 5  
Order #145-2  
Two round lights for Diamond Back LSR  
Order #145-3 Two oval lights  
Order #145-4 Three round lights  
Order #145-5 Three oval lights\*  
Order #145-6 One round light\*  
\* will not fit on models 317 or 318

**ADDITIONAL OPTIONS**

Order #	Description	Wt	Order #	Description	Wt	Order #	Description	Wt
128	Chain Rack Without Locking Cover	5	334	Lid Assembly for 24" Tray	4	145	Stop & Turn Light Bracket	5
1281	HD Chain Rack Without Locking Cover	7	331	Lid Assembly for Full Width Tray	14	413	Beacon Bracket, Sliding	9
147	Chain Rack With Locking Cover	7	330	Center Compartment w/Lid	26	377	Shelf Center Enclosure, 9" Deep	3
1471	HD Chain Rack With Locking Cover	9	335	Top Mount Tarp Tray	20	378	Shelf Center Enclosure, 18" Deep	6
333	Tray, 24" Wide 11.25" H x 8.5" D	13	392	Hose Hanger Assembly	5	379	Retainer, Chain Center Enclosure	3
333-18	Tray, 18" Wide 11.25" H x 8.5" D	11	341	Enclosure Shelf for Model 340	7	380	Chain Rack, Single	3
329	Tray, Full Width 11.25" H x 8.5" D	20	143	Load Light with Lexan Cover	1			
332	Divider Panel for Full Width Trays	1						

**Models and/or Specifications Subject to Change Without Notice.**

F.O.B. - Atlanta GA, Birmingham AL, Dallas TX, Henderson CO, Houston TX, Minneapolis MN, Nashville TN, Pittsburgh PA, Sacramento CA, Kansas City KS, Calgary, AB (Canada), Toronto, ON (Canada)





**OPTIONS AVAILABLE - ADD TO YOUR LSR BASE UNIT** (SEE PAGE 1B FOR DETAILS)



*Deluxe Option Kit-Full Tray  
with Two Locking Chain Racks*  
Order #328 Weight 28



*Deluxe Option Kit- 24" Trays or 18" Trays  
with Two Locking Chain Racks*  
Order #363 Weight 24



*Chain Rack with Locking Cover*  
Order #147 Weight 7  
Order #147-1 Weight 9



*Center 373-1 (44 x 10 x 26)  
Enclosure 375 (44 x 18 x 27)*  
Weight 373-1 (55) 375 (67)



*Side Enclosures 9" Deep*  
Order #381 Weight 63  
Not available on model 317



*Full Two or Three Door Enclosures - 14" O.D./11" I.D.*  
317=2 Door • 318, 319, 320, 321, 322=3 Door  
Order #340 Weight 118



*3 Door Deep Drop Enclosure - 14" O.D./11" I.D.*  
319, 320, 321 & 322 Models  
Order #390 Weight 116



*Full Two or Three Door Enclosures - 14" O.D./11" I.D.*  
317=2 Door • 318, 319, 320, 321, 322=3 Door  
Order #3400 Weight 118 W/Polished Aluminum Doors  
Order #3401 Weight 163 W/Stainless Steel Doors



*Jail Bar Three Door Enclosures - 14" O.D./11" I.D.*  
Order 3402 Weight 118

**Models and/or Specifications Subject to Change Without Notice.**

F.O.B. - Atlanta GA, Birmingham AL, Dallas TX, Henderson CO, Houston TX, Minneapolis MN, Nashville TN, Pittsburgh PA, Sacramento CA, Kansas City KS, Calgary, AB (Canada), Toronto, ON (Canada)



# LIMITED SECURITY RACK-BASE UNIT LSR

ORDER INFORMATION

Order #	Description/Dimensions H x W	Shipping Wt.	Maximum Static Load Resistance: Lbs.
317	Dyna-Light 68" x 70" Radius Corner	122	25,030 Lbs.
318	Dyna-Light 68" x 76" Radius Corner	125	25,695 Lbs.
319	Dyna-Light 68" x 86" Radius Corner	130	26,009 Lbs.
320	Dyna-Light 68" x 80" Radius Corner	128	23,798 Lbs.
321	Dyna-Light 73" x 78" For Mack CH series	133	23,042 Lbs.
322	Dyna-Light 75" x 86" Radius Corner	140	22,519 Lbs.
3750	Dyna-Light 80" x 76" Tall Cab Application	176	24,557 Lbs.
370	Diamondback 68" x 70" 45° Corner	122	24,058 Lbs.
371	Diamondback 68" x 86" 45° Corner	130	26,235 Lbs.
3172	Dyna-Light 68" x 61" Offset	115	23,585 Lbs.
3182	Dyna-Light 68" x 64" Offset	117	23,585 Lbs.
3192	Dyna-Light 68" x 69" Offset	120	23,585 Lbs.
3202	Dyna-Light 68" x 66" Offset	118	23,585 Lbs.
3212	Dyna-Light 73" x 68" Offset	126	23,585 Lbs.
3222	Dyna-Light 75" x 69" Offset	133	23,585 Lbs.

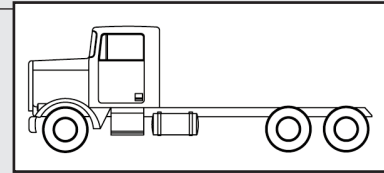

Model #317/318/370 • Conventional Without a Sleeper

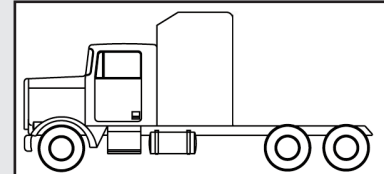

Model #320/319/322/371 • Conv. With Sleeper

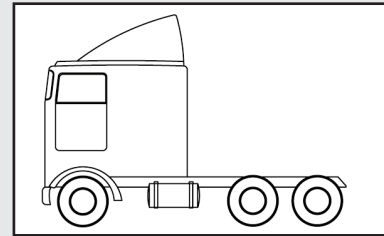

Model #319/320/322/371 • COE With Sleeper

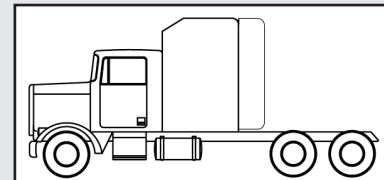

Model #320 • COE & Conv. W/Sleeper and Fairing Extensions

▲ Dyna-Light and Diamond Back LSR's have been tested by an independent engineering firm for maximum uniformly distributed static load.

▲ Must be Installed to Merritt Specifications with a Merritt Mounting Kit.

▲ Mounting Kits not Included. Reference Mounting Kit - Page 3A and 3B

▲ Merritt LSR's are not to be used in conjunction with log trailers or pole trailers.

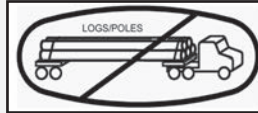

## WARNING LIMITED RESISTANCE TEST

Each model LSR has been designed and tested in conjunction with a Merritt Mounting Kit. Each model LSR has been tested to resist a maximum uniformly distributed static load as stated above.

Each model LSR offers limited resistance against impact. Merritt Equipment Co. makes no representations, implied or otherwise, except for the uniformly distributed static load resistance test as stated above. Any load or force in excess of the uniformly distributed static load resistance test may result in failure of this product which can result in serious injury or death.

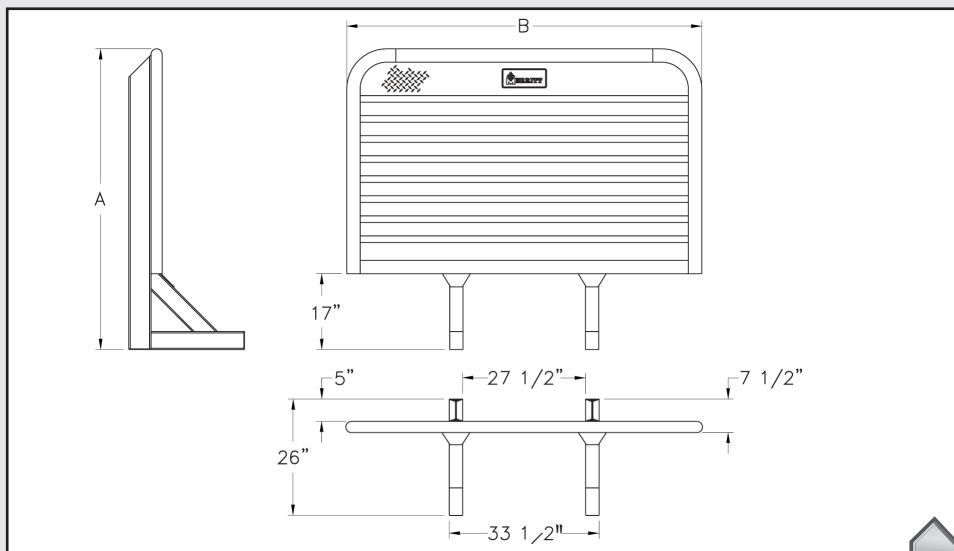

Model	A	B
317 / 370	68"	70"
318	68"	76"
319 / 371	68"	86"
320	68"	80"
321	73"	78"
322	75"	86"
3750	80"	76"
3172	68"	61"
3182	68"	64"
3192	68"	69"
3202	68"	66"
3212	73"	68"
3222	75"	69"

add these from above

Models and/or Specifications Subject to Change Without Notice.

F.O.B. - Atlanta GA, Birmingham AL, Dallas TX, Henderson CO, Houston TX, Minneapolis MN, Nashville TN, Pittsburgh PA, Sacramento CA, Kansas City KS, Calgary, AB (Canada), Toronto, ON (Canada)



- ▲ 7 models to choose from, to allow you flexibility for your needs.
- ▲ Metal surfaces are Zinc plated for durability and appearance.
- ▲ Dyna-Clamps can be mounted with u-bolt up or down position.

- ▲ Deluxe kit and Problem Solver kits for the times when items block the frame rail and a clamp will not work. (drilling required & nuts/bolts/washers not included for the side brackets)

- ▲ Stress blocks are included to fit between the u-bolt and the LSR leg. This spreads the clamping force over a larger area.

# LSR MOUNTING KITS



DYNA-CLAMP



## LSR MOUNTING KITS

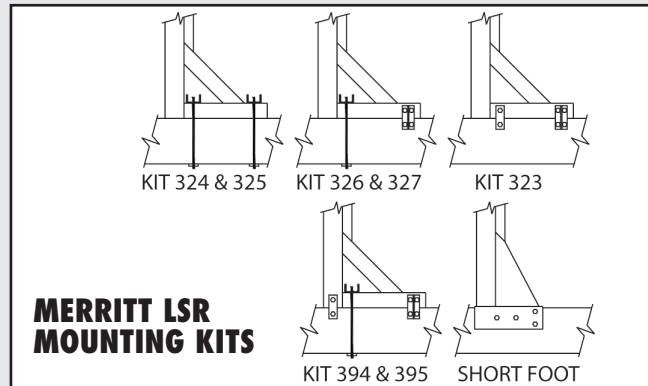
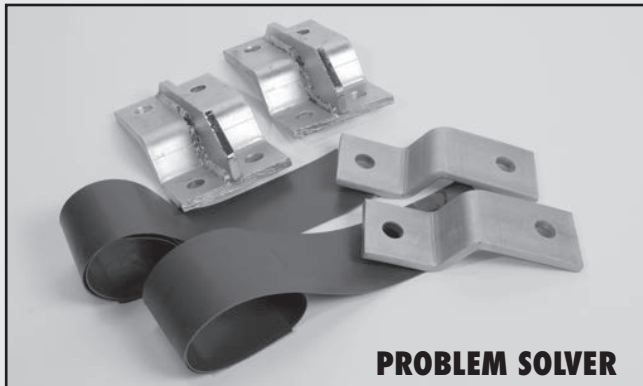
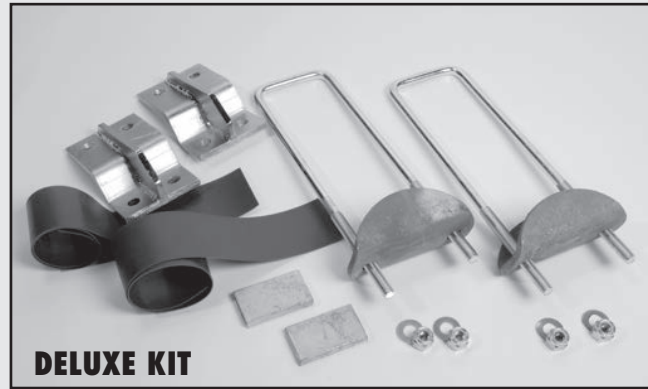
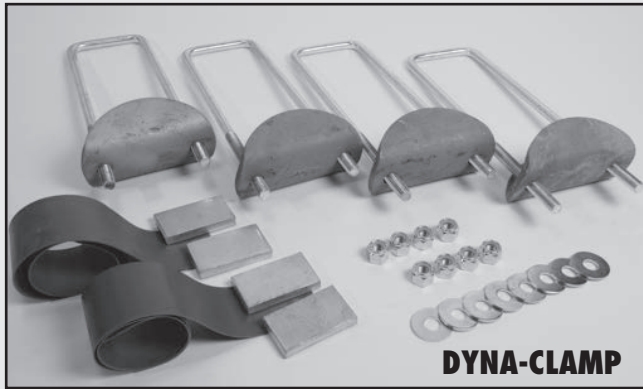

### DYNA-CLAMP\*

Order #	Description/Dimensions	Weight
324	Dyna-Clamp Kit (17" U-bolts) For Frame Rails 11" Deep or Less	31
325	Dyna-Clamp Kit (21" U-bolts) For Frame Rails Over 11"	33

*Designed for most installation needs*

*\*All parts zinc coated for corrosion resistance.*

### PROBLEM SOLVER\*

Order #	Description/Dimensions	Weight
323	Problem Solver Kit (nuts and bolts not included)	15

*Designed for difficult installations in and around air tanks, hanger brackets, crossmembers, fuel tanks, etc*

**MOUNTING KIT SELECTION:** Merritt offers several mounting kits as indicated in the diagram above. The operator is directed to select the best system for the application. If your installation application requires maximum attachment, we refer you to the 394 and 395 kits. If your installation application could be forced to move or slip on the frame, we refer you to any one of the systems 323, 326, 327, 394, 395 and the short foot which all bolt through the frame as part of the mounting.

### DELUXE KIT\*

Order #	Description/Dimensions	Weight
326	Deluxe Mounting Kit (17" U-bolts) For Frame Rails 11" Deep or Less	25
327	Deluxe Mounting Kit (21" U-bolts) For Frame Rails Over 11"	26

*Designed to give an extra option for problem installations.  
Two Brackets and Two U-Bolts.*

### 3-POINT MOUNTING KIT\*

Order #	Description/Dimensions	Weight
394	3-Point Mounting Kit (17" U-bolts) For Frame Rails 11" Deep or Less	35
395	3-Point Mounting Kit (21" U-bolts) For Frame Rails Over 11"	36

*Four Brackets and Two U Bolts.*

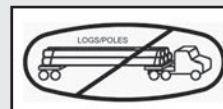

▲ Merritt LSR's are not to be used in conjunction with log trailers or pole trailers.

**Models and/or Specifications Subject to Change Without Notice.**

F.O.B. - Atlanta GA, Birmingham AL, Dallas TX, Henderson CO, Houston TX, Minneapolis MN, Nashville TN, Pittsburgh PA, Sacramento CA, Kansas City KS, Calgary, AB (Canada), Toronto, ON (Canada)

