

S7277

2015-2017 FORD MUSTANG GT,
COUPE ONLY, 5.0, CAT-BACK, 3.0" DUAL
REAR, STREET PROFILE

MBRP®

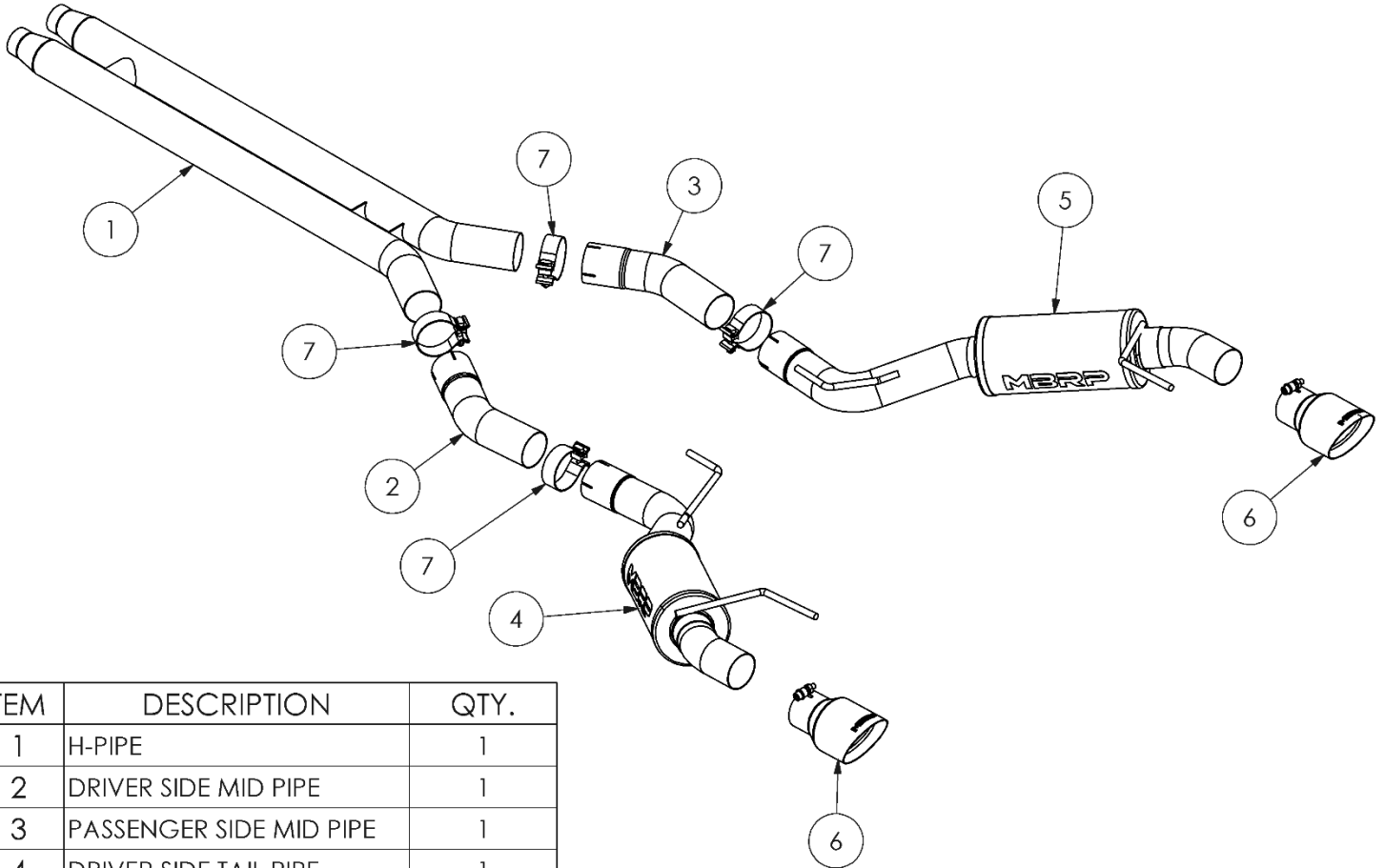

ITEM	DESCRIPTION	QTY.
1	H-PIPE	1
2	DRIVER SIDE MID PIPE	1
3	PASSENGER SIDE MID PIPE	1
4	DRIVER SIDE TAIL PIPE	1
5	PASSENGER SIDE TAIL PIPE	1
6	TIP	2
7	3.0" CLAMP	4

PLEASE READ BEFORE STARTING INSTALLATION

While MBRP has made every effort to ensure that all components of this system are of superior quality and properly packaged, it is the installer's responsibility to ensure the following before removal of the factory exhaust:

- that ALL components shown above are present.
- that ALL mating components fit together.
- that there are no damaged components.
- that the system you have purchased is appropriate for your vehicle year, model and configuration.
- that the system will not interfere with any modifications previously installed or planned.
- that you have read and understand these instructions.

If you have any questions or are uncertain about any aspect of the installation of this system to your vehicle please contact your dealer before commencing installation.

MBRP®

Removal of Stock System



Figure 1

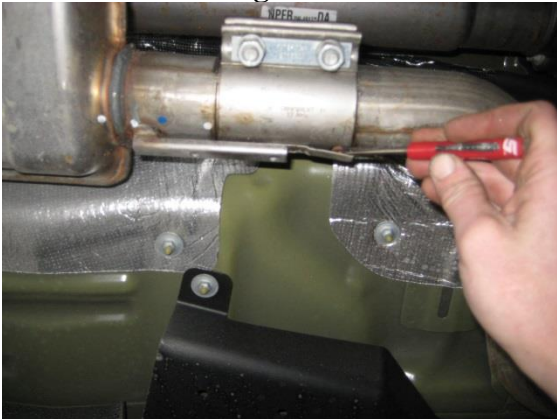

Figure 2



Figure 3

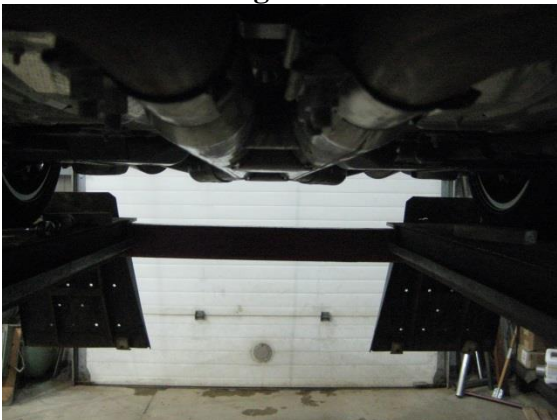

Figure 4

1. Apply a penetrating lubricant liberally to all exhaust fasteners, hangers and rubber insulators.

2. Remove the M8 bolts from the mid hanger brackets and remove them from the vehicle. Retain these parts as they will be reused.

Refer to Figure 1.

3. Loosen both clamps ahead of the resonator, lift the lock tabs and slide the clamps rearward to disconnect the OEM catback exhaust. Use caution, The OEM catback is one piece and heavy.

Refer to Figure 2.

4. Remove the OEM catback by lowering the inlet end and sliding the assembly forward to remove it from the rear hangers. Remove the OEM clamps as they will be reused.

5. Unbolt and remove the rear hanger brackets. Retain these parts, they will be reused.

Installation of MBRP Ltd. Performance Exhaust

1. Install the previously removed clamps onto the inlets of the **H Pipe** and install the assembly onto the vehicle with the flat side of the pipe support brackets facing the ground. Tighten the clamps enough to allow for adjustment while ensuring the **H Pipe** is level as viewed from the rear of the car.

Refer to Figures 3 and 4.

2. Install a **3" Clamp** onto each of the **H-Pipe** outlets. Install each of the **Mid Pipes** ensuring to use the correct pipe on each side.

Note: The **Mid Pipe** with the longer inlet length is the driver side pipe.

MBRP®



Figure 5

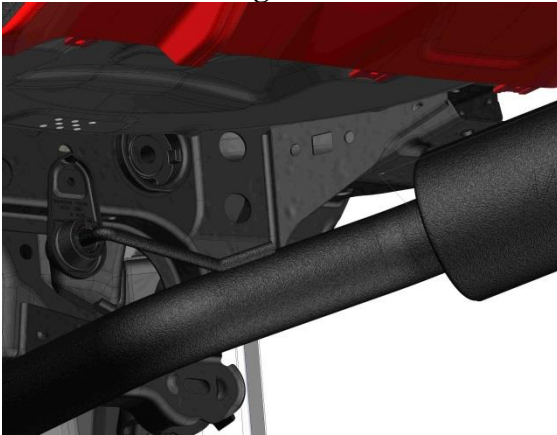

Figure 6



Figure 7

3. Install a **3" Clamp** onto each of the **Mid Pipe** outlets. Install the **Driver Side Muffler Assembly** by pre installing the mid hanger bracket, and rear hanger bracket in the appropriate locations on the **Driver Side Muffler Assembly**. Install the **Driver Side Muffler Assembly** onto the outlet of the **Mid Pipe** then install the mid and rear hanger brackets on the vehicle. The mid and rear hanger brackets have hooks that will hold them in position on the vehicle until the M8 bolts are reinstalled. Tighten the rear hanger bracket bolts but leave the mid hanger bracket bolt loose for now.

Refer to Figures 5 and 6.

4. Install the **Passenger Side Muffler Assembly** using the same procedure as illustrated in step 3. Tighten both 3" Clamps just enough to allow for adjustment.

5. Install both **Tips** and tighten just enough to allow for adjustment. **Refer to Figure 7.**

6. Align the exhaust as required. Tighten all hardware and clamps, starting at the front and working rearward to secure the system. Check along the full length of the exhaust system to ensure there is adequate clearance for fuel lines, vent lines, brake lines, frame, bodywork, suspension, and any wiring, etc. If there is any interference detected, relocate, or adjust to provide adequate clearance. Ensure all clamp connections are secure and components are unable to rotate or slide. Band clamps require approximately 45 lb-ft (60 N-m) of torque. Verify clearances, system security and band clamp torque after 30-60 miles (50-100 km) of driving

Note: The mid hanger brackets can be used to help center the **Tips** in the Facia. Once all clamps are tight, adjust the mid hanger brackets to fine tune the placement of the **Tips** then tighten the M8 bolts.

Congratulations! You are ready to begin experiencing the improved performance and driving pleasure of your **MBRP** performance exhaust system. We know you will enjoy your purchase.