

S6282

08-10 FORD 6.4L, F250/F350/450, 4"
PARTICULATE FILTER BACK w. DOWNPIPE

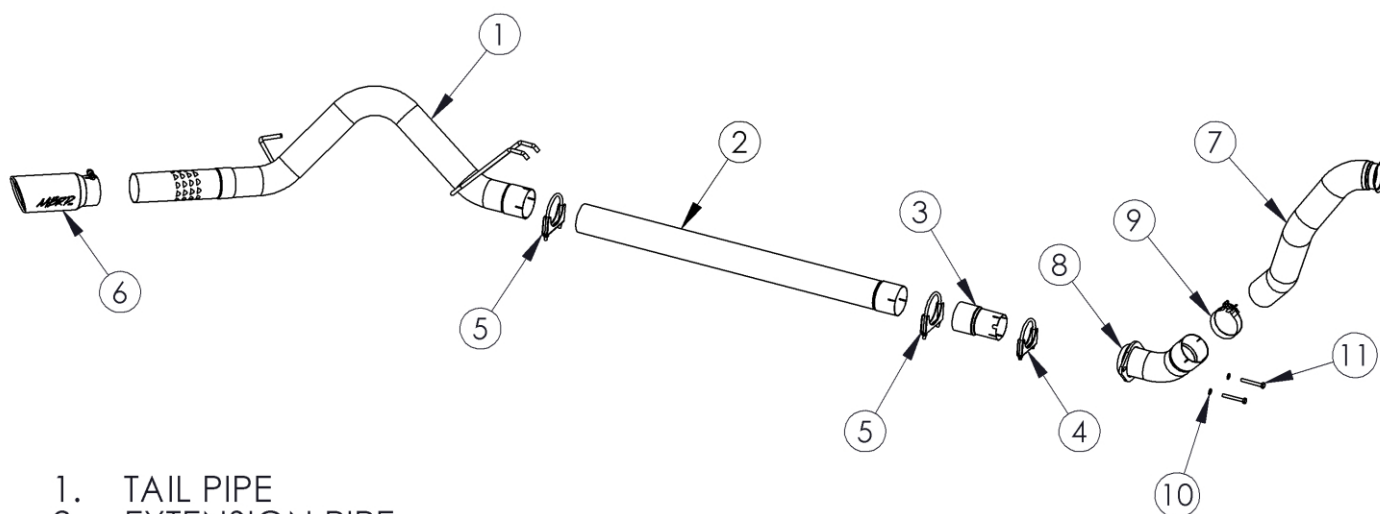

1. TAIL PIPE
2. EXTENSION PIPE
3. 3.5" TO 4" ADAPTER
4. 3.5" CLAMP
5. 4" CLAMP (2PCS)
6. EXHAUST TIP
7. LOWER DOWNPIPE
8. UPPER DOWNPIPE
9. 4" BAND CLAMP
10. WASHER (2 PCS)
11. BOLT (2 PCS)

PLEASE READ BEFORE STARTING INSTALLATION

While MBRP Inc. has made every effort to ensure that all components of this system are of superior quality and properly packaged it is the installer's responsibility to ensure the following before removal of the factory exhaust:

- that ALL components shown above are present.
- that ALL mating components fit together.
- that there are no damaged components.
- that the system you have purchased is appropriate for your vehicle year, model and configuration.
- that the system will not interfere with any modifications previously installed or planned.
- that you have read and understand these instructions.

If you have any questions or are uncertain about any aspect of the installation of this system to your vehicle, please contact your dealer before commencing installation.

2008 Ford Super Duty 6.4L Powerstroke Diesel

Removal of Stock System:



Figure 1



Figure 2

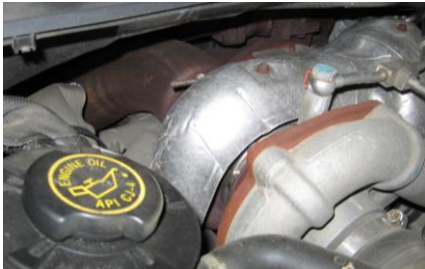

Figure 3



Figure 4



Figure 5

Filter-back exhaust:

1. Apply some penetrating lubricant liberally to all exhaust fasteners, hangers and rubber insulators.
2. Loosen the nut on the band clamp located behind the particulate filter using a 15mm wrench or socket. **Refer to Figure 1.**
3. Cut the exhaust as shown in **Figure 2**. Remove the muffler and tail pipe from the OEM rubber insulators. Remove from the vehicle.

Down pipe:

4. Remove the heat shield from the turbo by removing the five 8mm head bolts. This shield cannot be fully removed but sliding it out of the way will allow access to the V band Clamp at the turbo outlet. **See Figure 3.**
5. Loosen the OEM V-band Clamp at the turbo outlet. Once loose, the clamp bolt can be released from the clamp. There is a retaining tab located at the 12 o'clock position on the OEM down pipe that must be pried off the turbo flange to allow the pipe assembly to be removed. **Refer to Figure 4.**
6. Remove the 2 OEM bolts from the ball flange at the outlet of the down pipe. Keep these bolts, they will be reused. Use a pry-bar to shift the particulate filter rearward to allow the OEM down pipe to drop down a few inches.
7. The OEM down pipe must be cut in order to remove it. Use a sawsall with a long enough blade to cut through the pipe. Note the location of the cut. **Refer to Figure 5.**
8. Remove the lower section of the OEM down pipe. The upper section of the down pipe can now be removed by working the down pipe down while rotating it clockwise approx 90 degrees as viewed from below. This will take some work, as it is a very tight fit.

Installation of MBRP Inc. Performance Exhaust:

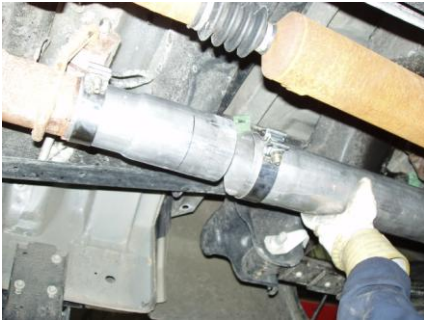

Figure 7



Figure 8



Figure 9



Figure 10

Filter-back exhaust:

1. The **Extension Pipe** provided is pre-cut for the crew cab long bed configuration. Cut the **Extension Pipe** to the required length for the vehicle being installed to. **Refer to Figure 6.**

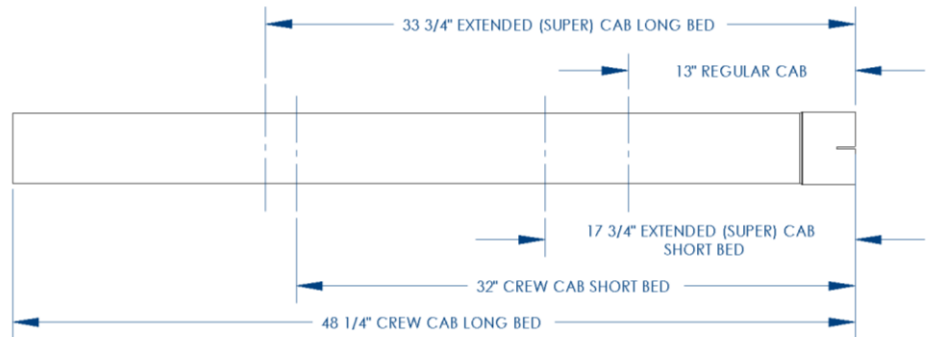

Figure 6

2. Slide the **3 1/2\"**
3. Slide the **4\"**
4. Install the Tail Pipe onto the Extension Pipe. Install the **Tail Pipe** hangers into the OEM rubber insulators. The clamp should remain loose enough for adjustability. **Refer to Figure 8.**
5. Install the **Exhaust Tip** using a 17mm wrench. Align the exhaust as required. Starting at the front of the exhaust, tighten all clamps and connections.
6. Check along the length of the exhaust system to ensure that there is adequate clearance around the spare tire, fuel and brake lines or any wiring. If any interference is detected, relocate or adjust as necessary.

Down pipe:

7. Install the **Upper Pipe** in the reverse order of removing the upper section of the OEM pipe. Again, it is tight, but it will fit. Once the **Upper Pipe** is in position, loosely install the OEM V-band Clamp. **See Figure 9.**
8. Install the **Lower Pipe** by first sliding the supplied **4\"**



9. Using the supplied **M10 Hex Bolts**, loosely secure the 2 bolt down pipe flange to the OEM flange. **Refer to Figure 10.**

10. Ensure that there is enough clearance between the MBRP Downpipe Assembly and the firewall, transmission cooler lines, and frame. Adjust if necessary. Once clearances have been checked, tighten all clamps and flanges.

11. Reinstall the OEM turbo heat shield with the previously removed hardware.



Congratulations! You are ready to begin experiencing the improved power, sound and driving experience of your MBRP Inc. performance exhaust system. We hope you enjoy your purchase.