

S62530

2015-16 FORD F250/F350/F450 6.7L
POWERSTROKE CREWCAB & SUPERCAB,
DPF-BACK, 5" SINGLE SIDE

MBRP
INC.
PERFORMANCE EXHAUST

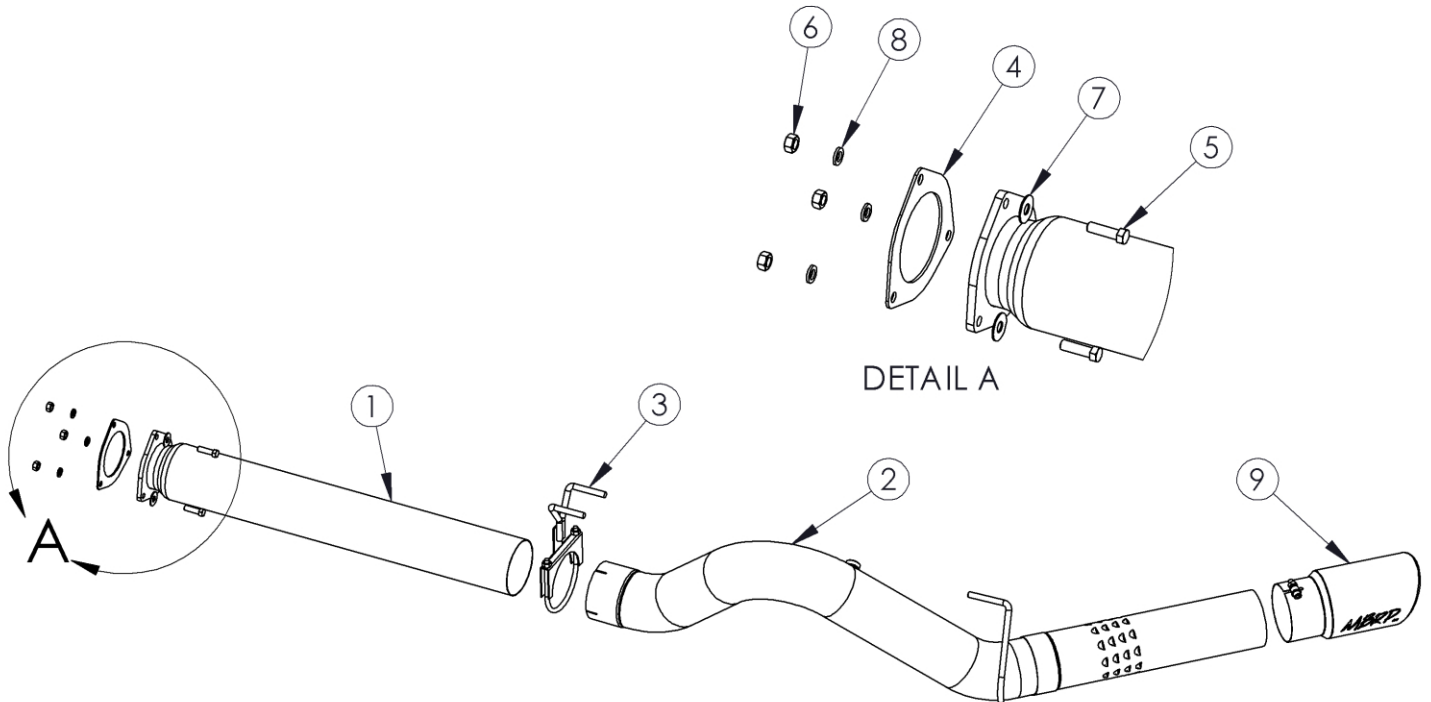

1. 5" EXTENSION PIPE
2. TAIL PIPE
3. 5" HANGER CLAMP
4. FLANGE GASKET
5. 7/16" HEX BOLT (3 PCS)
6. 7/16" HEX NUT (3PCS)
7. 7/16" FLAT WASHER (3 PCS)
8. 7/16" LOCK WASHER (3 PCS)
9. EXHAUST TIP

PLEASE READ BEFORE STARTING INSTALLATION

While MBRP Inc. has made every effort to ensure that all components of this system are of superior quality and properly packaged, it is the installer's responsibility to ensure the following before removal of the factory exhaust:

- that ALL components shown above are present.
- that ALL mating components fit together.
- that there are no damaged components.
- that the system you have purchased is appropriate for your vehicle year, model and configuration.
- that the system will not interfere with any modifications previously installed or planned.
- that you have read and understand these instructions.

If you have any questions or are uncertain about any aspect of the installation of this system to your vehicle please contact your dealer before commencing installation.

Removal of Stock System

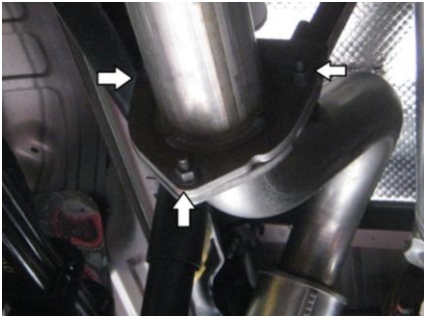

Figure 1

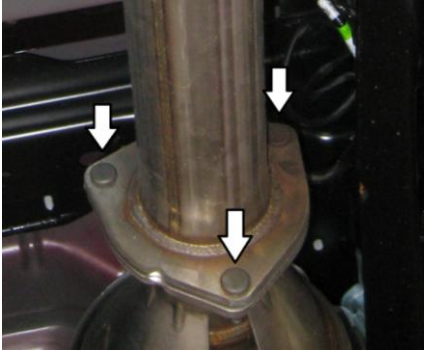

Figure 2

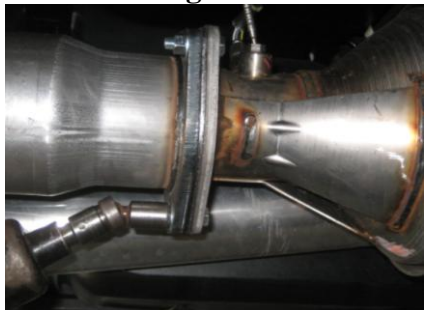

Figure 4



Figure 5



Figure 6

1. Apply some penetrating lubricant to all exhaust fasteners, hangers, and rubber insulators.
2. Loosen the three (3) nuts securing the extension pipe flange to the over-axle pipe. **Refer to Figure 1.**
3. Remove the temperature sensor from the over-axle/tail pipe. Remove the factory over-axle/tail pipe.
4. Loosen the three (3) nuts securing the extension pipe to the flange directly behind the exhaust filter and remove the extension pipe. **Refer to Figure 2.**

Installation of MBRP Inc. Performance Exhaust

1. The **Extension Pipe** is pre-cut for the 172.4" (crew-cab long-box) wheelbase. Cut the **Extension Pipe** to the appropriate length for the installation vehicle. **Refer to Figure 3.**

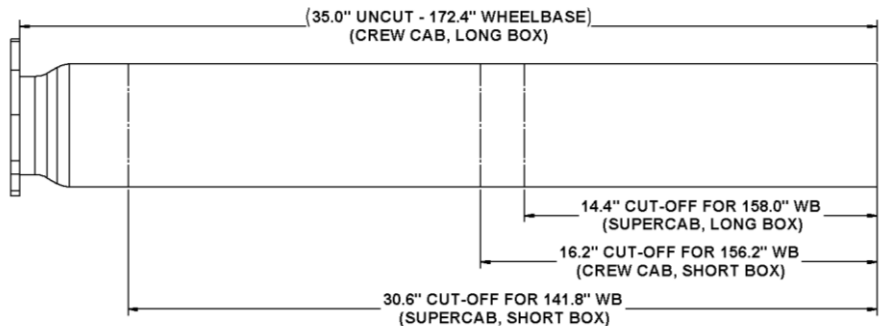

Figure 3

2. Mate the **Extension Pipe** flange to the stock exhaust flange with the **Gasket** between them and fasten the flanges together with the hardware provided. **Refer to Figure 4.**
3. Fit the **Hanger Clamp** loosely over the end of the extension pipe and insert the hangers into the rubber isolators.
4. Install the **Tail Pipe** onto the **Extension Pipe**, inserting the hanger into the rearward factory rubber isolator. **Refer to Figure 5.**
5. Align the exhaust as required and tighten the **Hanger Clamp**.
6. Attach temperature sensor to bung on **Tail Pipe**. **Refer to Figure 6.**
7. Install and adjust the **Exhaust Tip** to suit. Tighten the lock bolt located on the **Exhaust Tip**.
8. Ensure that there is adequate clearance around the spare tire or any fuel and brake lines.

Congratulations! You are ready to begin experiencing the improved power, sound, and driving experience of your MBRP Inc. performance exhaust system. We know you will enjoy your purchase.