

S62340P

03-07 FORD F250/F350 6.0L
POWERSTROKE, TURBO BACK (STOCK
CAT), 5" SINGLE SIDE

MBRP

INC.

PERFORMANCE EXHAUST

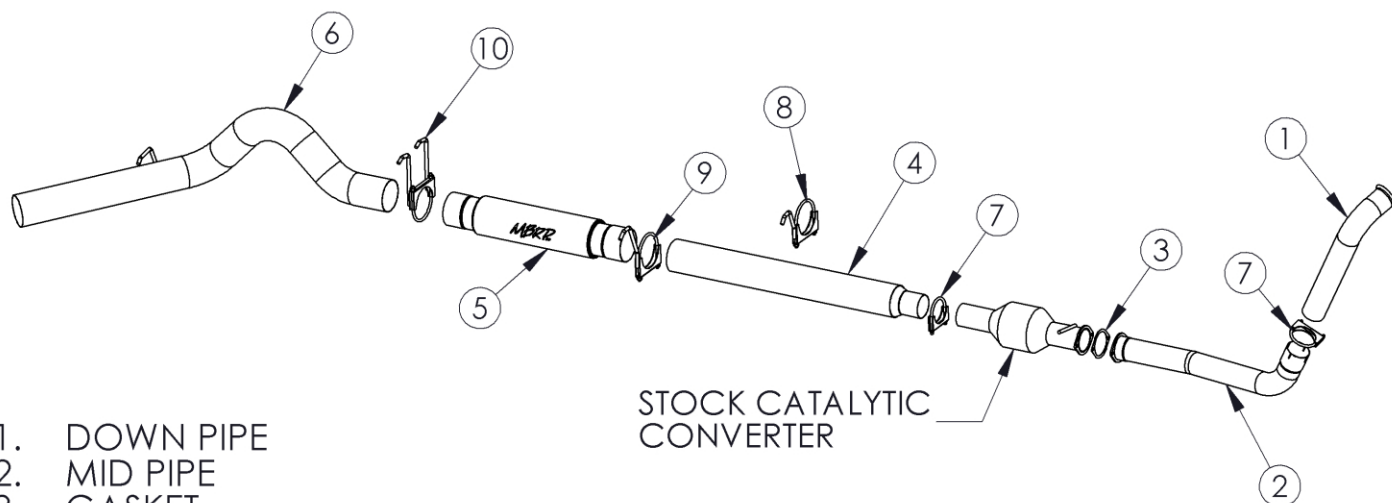

1. DOWN PIPE
2. MID PIPE
3. GASKET
4. 3.5" TO 5" EXTENSION PIPE - 44"
5. HIGH FLOW MUFFLER
6. TAIL PIPE
7. 3.5" CLAMP (2PCS)
8. 5" HANGER CLAMP
9. 5" HANGER CLAMP
10. 5" HANGER CLAMP

STOCK CATALYTIC
CONVERTER

PLEASE READ BEFORE STARTING INSTALATION

While MBRP Inc. has made every effort to ensure that all components of this system are of superior quality and properly packaged it is the installer's responsibility to ensure the following before removal of the factory exhaust:

- that ALL components shown above are present.
- that ALL mating components fit together.
- that there are no damaged components.
- that the system you have purchased is appropriate for your vehicle year, model and configuration.
- that the system will not interfere with any modifications previously installed or planned.
- that you have read and understand these instructions.

If you have any questions or are uncertain about any aspect of the installation of this system to your vehicle please contact your dealer before commencing installation.

Removal of stock system:

1. Loosen the nut on the clamp located behind the catalytic converter using a 15mm wrench or socket.
2. Remove the muffler and tail pipe from the OEM rubber hangers. On 03-04 trucks remove bottom shock bolt of the passenger side shock to remove the system in one piece. **This is not required on 05 and newer models.** Separate the stock exhaust at the slip joint located behind the catalytic converter and remove the muffler and tail pipe from under the truck. **Re-install the bottom shock bolt.**
3. Remove the catalytic converter by removing the two nuts holding the inlet flange together using a 15mm wrench or socket. Retain the nuts for the re-installation of the catalytic converter.
4. Using a 15mm wrench or socket, remove the catalytic converter by removing the two nuts holding the inlet flange together.
5. Remove the down pipe from the turbo by removing the clamp using an 11mm socket. Retain the clamp for the installation of the new down pipe. Cut the down pipe in front of the transmission cross member to remove. (**Note:** The stock down pipe can be removed in one piece by removing the transmission cross member. It is recommended that this only be done by qualified, trained professionals using tools and equipment designed to safely carry out this procedure.)
6. Remove the spare tire. You may not be able to reinstall your spare tire after the installation of this exhaust system.

Installation of MBRP Inc. Performance Exhaust:

1. Install the **Down Pipe** in the same position as the stock down pipe and attach the flared end to the turbo using the stock band clamp. Do not fully tighten until all components are in place.
2. Attach the **Mid Pipe** to the **Down Pipe** using the **3.5" Clamp** to secure the slip joint.
3. Attach the factory catalytic converter to the **Mid Pipe** by placing the gasket supplied between the flanges and installing the two nuts that were removed previously.
4. Install the **3.5" to 5" Extension Pipe** over the OEM pipe behind the **Catalytic Converter**. The **Extension Pipe** is pre-cut to fit a crew cab long bed truck. For extended cab long bed trucks the **Extension Pipe** needs to be cut to a length of 26.5". For crew cab short bed trucks the **Extension Pipe** needs to be cut to a length of 24.5". For extended cab short bed trucks the **Extension Pipe** needs to be cut to a length of 11.25".

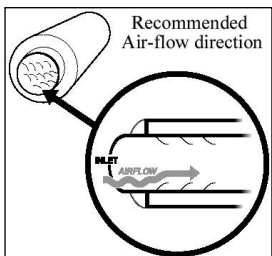

5. Install the **Hanger Clamp** into the OEM rubber hanger located on the frame beside the inlet of the **Muffler**.
6. Install the **Muffler** over the **Extension Pipe** so that the exhaust will flow smoothly over the louvers. Refer to the illustration on the left.
7. Install the **Hanger Clamp** into the two OEM rubber hangers located above the outlet of the **Muffler**.
8. Install the **Tail Pipe** from the rear of the truck, over the axle and attach to the outlet of the **Muffler**. Install tail pipe hanger into the OEM hanger to complete.
9. Install the provided clamps around pipes where needed. Adjust the **Tail Pipe** and check along the whole length of the exhaust system to ensure there is adequate clearance around the fuel and brake lines or any wiring. If any interference is detected relocate or adjust.
10. Make sure exhaust is in place before tightening clamps. Start at the front of the exhaust system and tighten all connections.
11. If a tip has been purchased, install and adjust to suit. Tighten lock bolt located on the **Tip**. **A Tip is not included with this kit.** Tips may be purchased separately, check with your dealer.

Congratulations! You are ready to begin enjoying the improved performance and driving experience of your MBRP Inc. performance exhaust system. We hope you enjoy your purchase.