

S6218P

94-97 FORD F250/350 7.3L POWERSTROKE, TURBO BACK, OFF ROAD, AUTOMATIC ONLY, 4"
SINGLE SIDE

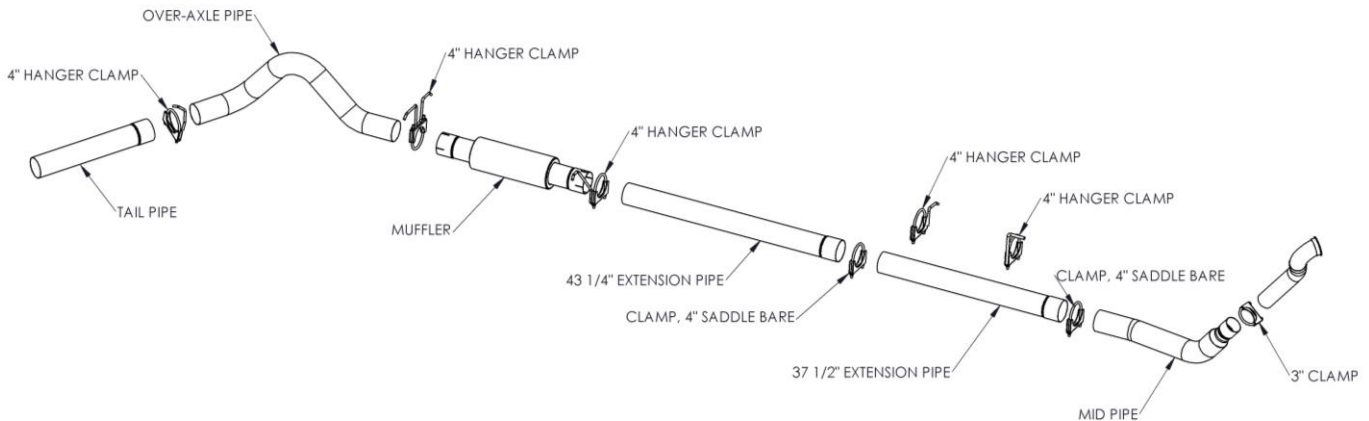

PLEASE READ BEFORE STARTING INSTALLATION

MBRP Inc. has made every effort to ensure that all components of this system are of superior quality and properly packaged. It is the installer's responsibility to ensure that all components are present and fit together as shown. Please also ensure that all components are undamaged before removal of the factory exhaust. Finally check that this system properly matches the make and model of the vehicle and will not interfere with previous or planned modifications.

Removal of stock FORD system:

Note: will not work with standard transmission

1. Loosen the nut on the band clamp located behind the catalytic converter.
2. Remove the muffler and tail pipe from the OEM rubber hangers. Separate the stock exhaust at the slip joint located behind the catalytic converter and remove the muffler and tail pipe from under the truck.
3. Remove the catalytic converter by removing the two nuts holding the inlet flange together.
4. From underneath the vehicle cut the factory down pipe as high as can be reached safely. Again cut the down pipe from above, as far from the turbocharger as safely possible. Remove the remaining piece of the down pipe from the turbo by removing the band clamp. Retain the band clamp for the installation of the new down pipe.

Installation of MBRP Inc. Performance Exhaust:

1. Install the Down Pipe in the same position as the stock down pipe. You will need to create room for this Down Pipe by bending back the pinch weld connecting the firewall to the floor in the area where the Down Pipe will pass through. Make sure that there is adequate clearance around the Down Pipe so that there will not be any interference after the Down Pipe is installed. Connect the flared end of the Down Pipe to the turbo using the stock band clamp. Do not fully tighten until all components are in place.
2. Attach the Mid Pipe to the Down Pipe using the 3" Clamp supplied to secure the slip joint. Install the Hanger Clamp into the rubber insulator previously used for the catalytic converter and secure to the Mid Pipe.
3. Hang the "T" Hanger Clamp in the factory rubber insulators. The insulators are located right above where the rear outlet of the factory muffler was located.
4. Temporarily install the Muffler in place and measure from the front of the Muffler to the Mid Pipe. Cut the Extension Pipes to result in the required combined length.
5. Attach the Extension Pipes to the Mid Pipe. Place the Hanger Clamp into the rubber insulator located on the frame beside this joint and loosely install around the slip joint.
6. Install the Muffler over the Extension Pipe and loosely install the "T" Hanger Clamp over the end of the Muffler. Place the appropriate 4" Hanger Clamp into the rubber insulator located on the frame beside this joint and loosely install around slip joint.
7. Install the Tail Pipe and Over Axle Pipe from the rear of the truck, over the axle and attach to the Muffler outlet. Install the appropriate 4" Hanger Clamp into the OEM hanger to complete.
8. Add remaining 4" Clamps where required. Adjust the Tail Pipe and check along the whole length of the exhaust system to ensure that there is adequate clearance around the spare tire, fuel and brake lines or any wiring. If any interference is detected relocate or adjust. Start at the front of the exhaust system and begin tightening all connections.

Congratulations! You are ready to begin experiencing the improved power, sound and driving experience of your MBRP Inc. performance exhaust system. We hope you enjoy your purchase.