

S6218

94-97 FORD F250/350 7.3L POWERSTROKE,
TURBO BACK, OFF ROAD, AUTOMATIC
ONLY, 4" SINGLE SIDE

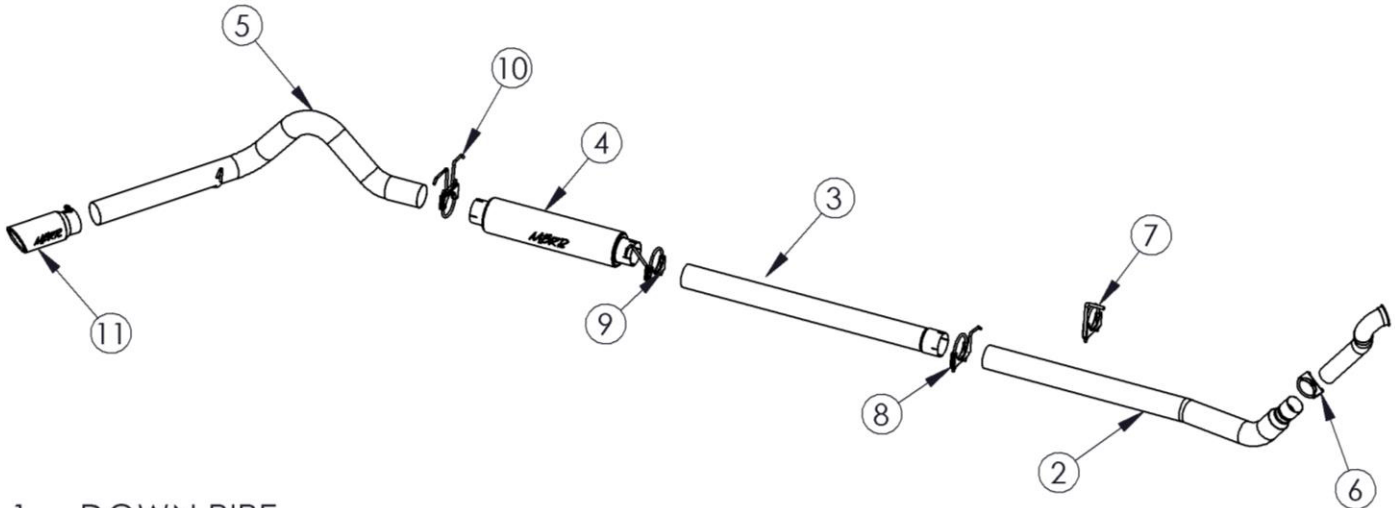

**NOTE: WILL NOT WORK WITH
STANDARD TRANSMISSION**



1. DOWN PIPE
2. MID PIPE
3. EXTENSION PIPE
4. HIGH FLOW MUFFLER
5. TAIL PIPE
6. 3" CLAMP
7. 4" HANGER CLAMP
8. 4" HANGER CLAMP
9. 4" HANGER CLAMP
10. 4" "T" - HANGER CLAMP
11. EXHAUST TIP

PLEASE READ BEFORE STARTING INSTALATION

While MBRP Inc. has made every effort to ensure that all components of this system are of superior quality and properly packaged it is the installer's responsibility to ensure the following before removal of the factory exhaust:

- that ALL components shown above are present.
- that ALL mating components fit together.
- that there are no damaged components.
- that the system you have purchased is appropriate for your vehicle year, model and configuration.
- that the system will not interfere with any modifications previously installed or planned.
- that you have read and understand these instructions.

If you have any questions or are uncertain about any aspect of the installation of this system to your vehicle please contact your dealer before commencing installation.



Removal of stock FORD system:

1. Loosen the nut on the band clamp located behind the catalytic converter.
2. Remove the muffler and tail pipe from the OEM rubber hangers. Separate the stock exhaust at the slip joint located behind the catalytic converter and remove the muffler and tail pipe from under the truck.
3. Remove the catalytic converter by removing the two nuts holding the inlet flange together.
4. From underneath the vehicle cut the factory down pipe as high as can be reached safely. Again cut the down pipe from above, as far from the turbocharger as safely possible. Remove the remaining piece of the down pipe from the turbo by removing the band clamp. Retain the band clamp for the installation of the new down pipe.

Installation of MBRP Inc. Performance Exhaust:

1. Install the Down Pipe in the same position as the stock down pipe. You will need to create room for this **Down Pipe** by bending back the pinch weld connecting the firewall to the floor in the area where the **Down Pipe** will pass through. Make sure that there is adequate clearance around the **Down Pipe** so that there will not be any interference after the **Down Pipe** is installed. Connect the flared end of the **Down Pipe** to the turbo using the stock band clamp. Do not fully tighten until all components are in place.
2. Attach the **Mid Pipe** to the **Down Pipe** using the **3" Clamp** supplied to secure the slip joint. Install the **Hanger Clamp** into the rubber insulator previously used for the catalytic converter and secure to the **Mid Pipe**.
3. Hang the **"T" Hanger Clamp** in the factory rubber insulators. The insulators are located right above where the rear of the factory muffler was located.
4. Temporarily install the **Muffler** in place and measure from the front of the **Muffler** to the **Mid Pipe**. This will give you the required length to cut the **Extension Pipe**.
5. Cut the **Extension Pipe** to the required length. Attach the **Extension Pipe** to the **Mid Pipe**. Place the **Hanger Clamp** into the rubber insulator located on the frame beside this joint and loosely install around the slip joint.

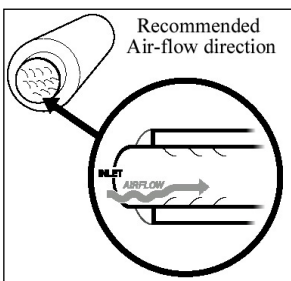

6. Install the **Muffler** over the **Extension Pipe** and loosely install the **"T" Hanger Clamp** over the end of the **Muffler**. Place the remaining **Hanger Clamp** into the rubber insulator located on the frame beside this joint and loosely install around slip joint.



7. Install the **Tail Pipe** from the rear of the truck, over the axle and attach to the **Muffler** outlet. Install the tail pipe hanger into the OEM hanger to complete.
8. Adjust the **Tail Pipe** and check along the whole length of the exhaust system to ensure that there is adequate clearance around the spare tire, fuel and brake lines or any wiring. If any interference is detected relocate or adjust.
9. Make sure the exhaust is in place before tightening clamps. Start at the front of the exhaust system and begin tightening all connections.
10. Install and adjust **Tip** to suit. Using a 17mm wrench tighten lock bolt located on **Tip**.

Congratulations! You are ready to begin enjoying the improved performance and driving experience of your MBRP Inc. Performance Diesel Exhaust system. We hope you enjoy your purchase.