

S6104

03-04 DODGE CUMMINS, 2500/3500,
TURBO BACK

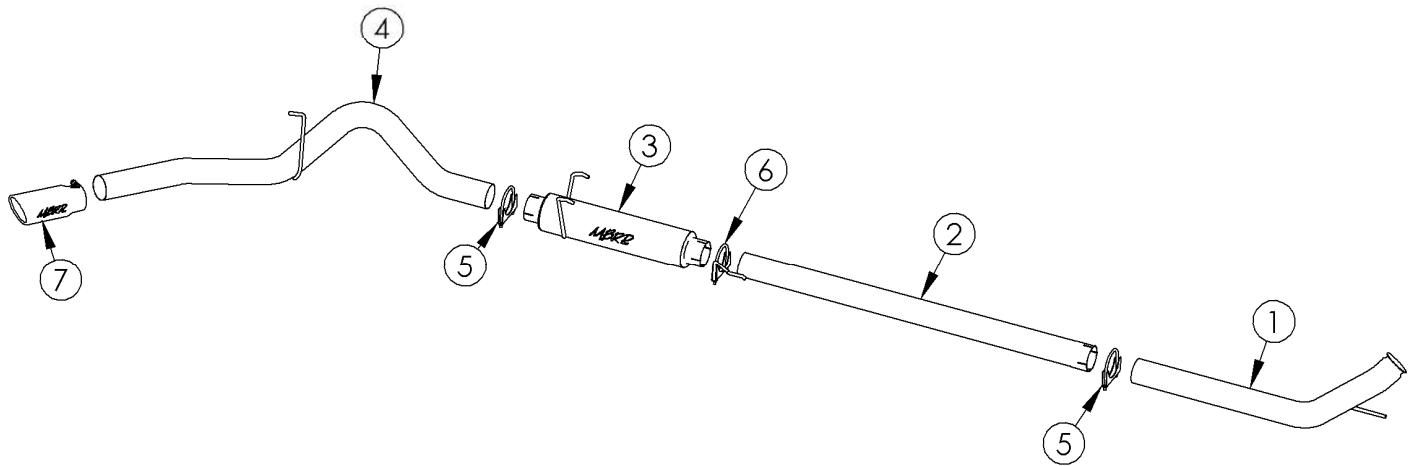

1. DOWN PIPE
2. EXTENSION PIPE
3. HIGH FLOW MUFFLER
4. TAIL PIPE
5. 4" CLAMP (2PCS)
6. 4" HANGER CLAMP
7. EXHAUST TIP

PLEASE READ BEFORE STARTING INSTALLATION

While MBRP Inc. has made every effort to ensure that all components of this system are of superior quality and properly packaged, it is the installer's responsibility to ensure the following before removal of the factory exhaust:

- that ALL components shown above are present.
- that ALL mating components fit together.
- that there are no damaged components.
- that the system you have purchased is appropriate for your vehicle year, model and configuration.
- that the system will not interfere with any modifications previously installed or planned.
- that you have read and understand these instructions.

If you have any questions or are uncertain about any aspect of the installation of this system to your vehicle please contact your dealer before commencing installation.



Figure 1



Figure 2



Figure 3



Figure 4

Removal of Stock System

1. Apply a penetrating lubricant liberally to all exhaust fasteners, hangers and rubber insulators.
2. Remove the exhaust system from the rubber insulators and remove all of the clamps from the system.
3. Separate the slip joint behind the muffler and remove the tail pipe.
4. Separate the slip joint connecting the down pipe and the extension pipe. Remove the muffler and extension pipe.
5. Loosen the band clamp connecting the down pipe to the turbo and remove the down pipe. **Do not discard the band clamp as it is required for the installation. Refer to Figure 1.**

Installation of MBRP Inc. Performance Exhaust

1. Install the **Down Pipe** in the same position as the stock down pipe by sliding the hanger into the OEM hanger bracket and then attaching the flared end to the turbo using the stock band clamp. Do not fully tighten until all components are in place. **Refer to Figure 2.**
2. Install the **Extension Pipe** over the **Down Pipe**. The **Extension Pipe** may require cutting to accommodate vehicles other than the Quad Cab long bed. (**Installation tip:** Temporarily hang the muffler in place using the three OEM rubber hangers and measure from the muffler to the down pipe to determine the length required.) **Refer to Figure 3.**



Figure 5



Figure 6



Figure 7



Figure 8

3. Install the **Muffler** over the **Extension Pipe** and into the OEM rubber hangers. **Refer to Figure 4.**

4. Remove the factory rubber insulator for the factory tail pipe and install it onto the **Tail Pipe** hanger. Install the **Tail Pipe** from the rear of the truck, over the axle. Attach it to the outlet of the **Muffler** and finish hanging the **Tail Pipe** by reinstalling the factory insulator. **Refer to Figures 5 & 6.**

5. Install the provided **Clamps** around the pipes where required. **Refer to Figure 7.**

6. Adjust the **Tail Pipe** and check along the whole length of the exhaust system to ensure there is adequate clearance around the fuel and brake lines or any wiring. If any interference is detected relocate or adjust.

7. Install and adjust the **Exhaust Tip** to suit. Using a 17mm wrench tighten the lock bolt located on the **Exhaust Tip**. **Refer to Figure 8.**

8. Align the exhaust as required. Starting at the front of the exhaust, tighten all clamps and connections.

Congratulations! You are ready to begin experiencing the improved power, sound and driving experience of your MBRP Inc. performance exhaust system. We hope you enjoy your purchase.