

S60200

01-07 CHEV/GMC 2500/3500 6.6L
DURAMAX, DOWN PIPE BACK (WITH
FRONT PIPE), OFF-ROAD,

MBRP
INC.
PERFORMANCE EXHAUST

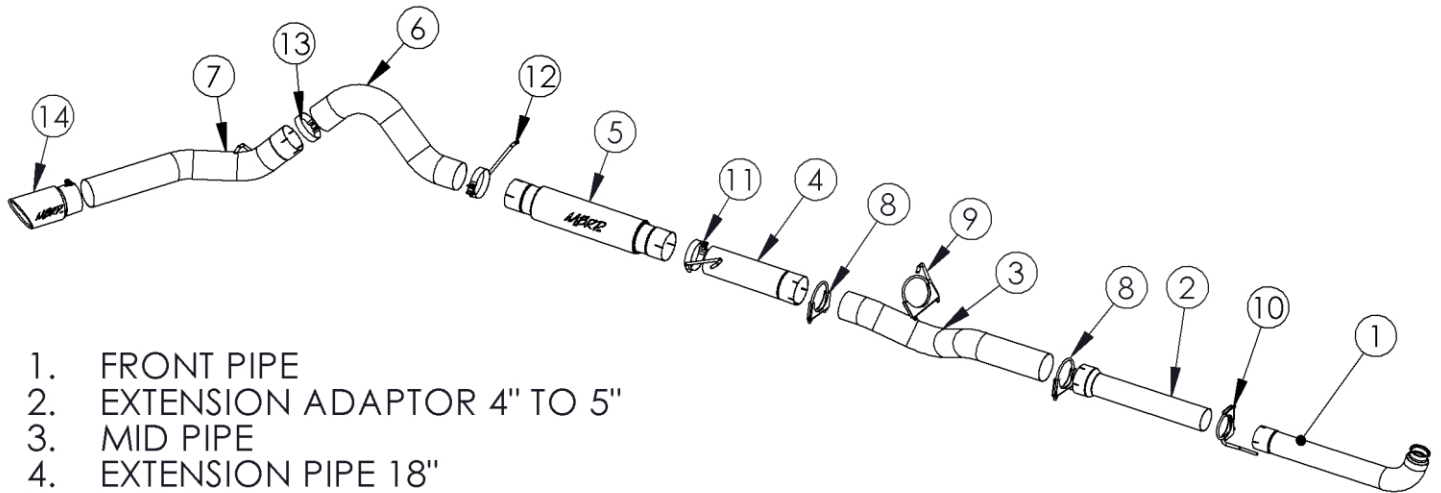

1. FRONT PIPE
2. EXTENSION ADAPTOR 4" TO 5"
3. MID PIPE
4. EXTENSION PIPE 18"
5. MUFFLER
6. OVER AXLE PIPE
7. TAIL PIPE
8. 5" CLAMP
9. 5" HANGER CLAMP
10. 4" HANGER CLAMP
11. 5" HANGER BAND CLAMP
12. 5" HANGER BAND CLAMP
13. 5" BAND CLAMP
14. EXHAUST TIP

PLEASE READ BEFORE STARTING INSTALATION

While MBRP Inc. has made every effort to ensure that all components of this system are of superior quality and properly packaged it is the installer's responsibility to ensure the following before removal of the factory exhaust:

- that ALL components shown above are present.
- that ALL mating components fit together.
- that there are no damaged components.
- that the system you have purchased is appropriate for your vehicle year, model and configuration.
- that the system will not interfere with any modifications previously installed or planned.
- that you have read and understand these instructions.

If you have any questions or are uncertain about any aspect of the installation of this system to your vehicle please contact your dealer before commencing installation.

Removal of stock system:

1. Apply a penetrating lubricant liberally to all exhaust fasteners, hangers and rubber insulators.
2. Using a 15mm socket or wrench, disconnect the factory exhaust system at the four bolt flange located behind the catalytic converter. If the vehicle is not equipped with a catalytic converter disconnect the four bolt flange located approximately under the passenger side seat.
3. Remove the exhaust system from the rubber insulators and remove from under the vehicle. If a hoist is not available for use, it may be necessary to cut the tail pipe behind the muffler for removal of the system.
4. Unbolt the OEM hanger from the transmission and remove.
5. Loosen the factory clamp and remove the stock front pipe. Some vehicles are not equipped with a catalytic converter. **Do not discard the clamp as it is required for the installation.**
6. Remove the spare tire. You may not be able to reinstall your spare tire after the installation of this exhaust system.

Installation of MBRP Inc. Performance Exhaust:

1. Install the Front Pipe onto the factory Down Pipe using the band clamp removed previously. Do not fully tighten to allow for adjustment.
2. Install the hanger removed previously by sliding the outside hole in the rubber insulator over the **4" Hanger Clamp** on the **Front Pipe** and re-connect to the transmission.
3. Install the **Extension Adaptor 4" to 5"** into the **Front Pipe**. The **Extension Adaptor** pipe does not require cutting to fit crew cab trucks. For extended cab trucks, approximately 9½" needs to be cut off the **Extension Adaptor**. Installation tip: Temporarily hang the **Tail Pipe, Over Axle, Muffler Delete, Extension Pipe** (if required) and **Mid Pipe** in place and measure to the **Front Pipe** to verify the length required.
4. Rotate the **Extension Pipe** toward the drive shaft and loosely install the **5" Hanger Clamp**. This will support the Extension Pipe during the **Muffler** installation. Regular cab trucks do not require the installation of this **5" Hanger Clamp**.
5. Crew cab & extended cab long bed trucks require the use of the **18" Extension Pipe** provided. This is to be positioned between the **Muffler** and the **Mid Pipe**. The **18" Extension Pipe** is not required with short box trucks.

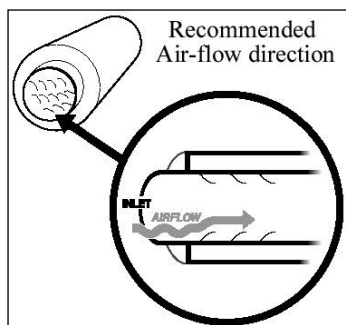

6. Install the **Muffler** over the required pipe so that the exhaust will flow smoothly over the louvers. Refer to the illustration on the left.
7. Install the **5" Hanger Band Clamp** into the OEM rubber hanger located on the frame above the inlet of the **Muffler**. Refer to the illustration on the 1st page.
8. Install the **Over Axle Pipe** and the **5" Hanger Band Clamp** to the **Muffler** outlet. Install the Tail Pipe onto the Over Axle Pipe using the **5" Band Clamp** provided and attach the hanger into the OEM rubber hanger. Adjust for best axle clearance and **Tail Pipe** exit location to complete. Install the remaining clamps where required, refer to illustration for clarification.

9. Install and adjust the **Exhaust Tip** to suit.
10. Adjust **Tail Pipe** and check along the whole length of the exhaust system to ensure there is adequate clearance around the fuel & brake lines, wiring and body panels. If any interference is detected relocate or adjust. Start at the front of the exhaust system and tighten all connections.

Congratulations! You are ready to begin enjoying the improved performance and driving experience of your MBRP Inc. performance exhaust system. We hope you enjoy your purchase.