

S5504

2006 - 2008, JEEP COMMANDER
4.7L & 5.7L HEMI, CAT BACK SINGLE

MBRP INC.

PERFORMANCE EXHAUST

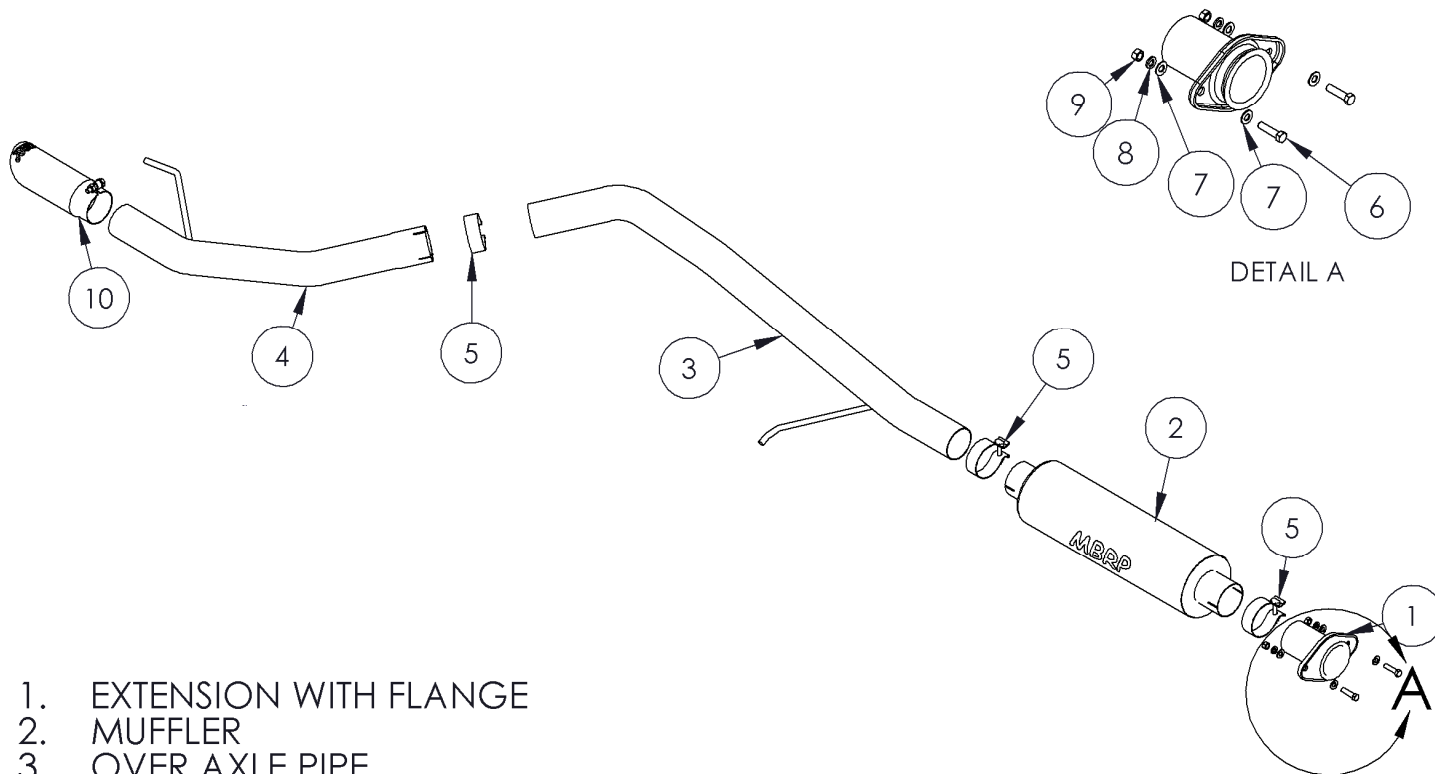

1. EXTENSION WITH FLANGE
2. MUFFLER
3. OVER AXLE PIPE
4. TAIL PIPE
5. 3" CLAMP (SADDLE CLAMP IN ALUMINIZED SYSTEM) (3PCS)
6. 3/8" x 1 1/2" BOLT (2PCS)
7. 3/8" WASHER (2PCS)
8. 3/8" LOCK WASHER (2PCS)
9. 3/8" NUT (2PCS)
10. EXHAUST TIP

PLEASE READ BEFORE STARTING INSTALATION

While MBRP Inc. has made every effort to ensure that all components of this system are of superior quality and properly packaged, it is the installer's responsibility to ensure the following before removal of the factory exhaust:

- that ALL components shown above are present.
- that ALL mating components fit together.
- that there are no damaged components.
- that the system you have purchased is appropriate for your vehicle year, model and configuration.
- that the system will not interfere with any modifications previously installed or planned.
- that you have read and understand these instructions.

If you have any questions or are uncertain about any aspect of the installation of this system to your vehicle please contact your dealer before commencing installation.

2007-2008 JEEP COMMANDER

Removal of stock system:



Figure 1

1. Apply a penetrating lubricant liberally to all exhaust fasteners, hangers and rubber insulators.



Figure 2

2. Cut the exhaust behind the muffler so that it can be removed from the vehicle. **Refer to Figure 1.** Note some vehicles will have a flange behind the muffler so cutting can be avoided.

3. Remove the nuts from the studs holding the front flange together and disconnect exhaust system. The ground strap will be reused on installation. **Refer to Figure 2.**



Figure 3

4. Remove the hangers from the rubber insulators. The rearmost hanger has a weighted nut which must be removed. Remove the exhaust from the vehicle. **Refer to Figure 3.**



Figure 4

Installation of MBRP Inc. Performance Exhaust:

1. Install the **Tail Pipe** hanger into the rearmost existing rubber isolator. **Refer to Figure 4.**



Figure 5

2. Slide a **3" Clamp** over the **Tail Pipe** and loosely install the **Over Axle Pipe** onto the **Tail Pipe**. Refer to **Figure 5**.



Figure 6

3. Slide a **3" Clamp** over the outlet side of the **Muffler**. Install the **Muffler** to the **Over Axle Pipe**. Slide a **3" Clamp** onto the inlet of the **Muffler** then install the **Extension Pipe and Flange**. Refer to **Figure 6**.

4. Install the **Extension Pipe Flange** to the existing flange using the fasteners provided. Refer to **Figure 7**.



Figure 7

5. Install the hanger for the **Over Axle Pipe** to the existing rubber insulator. Refer to **Figure 8**.

6. Install and adjust the **Exhaust Tip** to suit. Using a 17mm wrench tighten the lock bolt located on the **Exhaust Tip**. Refer to **Figure 9**.

7. Align the exhaust as required. Starting at the front of the exhaust, tighten all clamps and connections.



Figure 8

8. Check along the whole length of the exhaust system to ensure that there is adequate clearance around the spare tire, fuel and brake lines or any wiring. If any interference is detected relocate or adjust.



Figure 9



Congratulations! You are ready to begin experiencing the improved power, sound and driving experience of your MBRP Inc. performance exhaust system. We hope you enjoy your purchase.