

# S5408

CAT-BACK, 3" SINGLE-SIDE EXHAUST  
2016 + UP 5.6L NISSAN TITAN XD

**MBRP**  
INC.  
PERFORMANCE EXHAUST

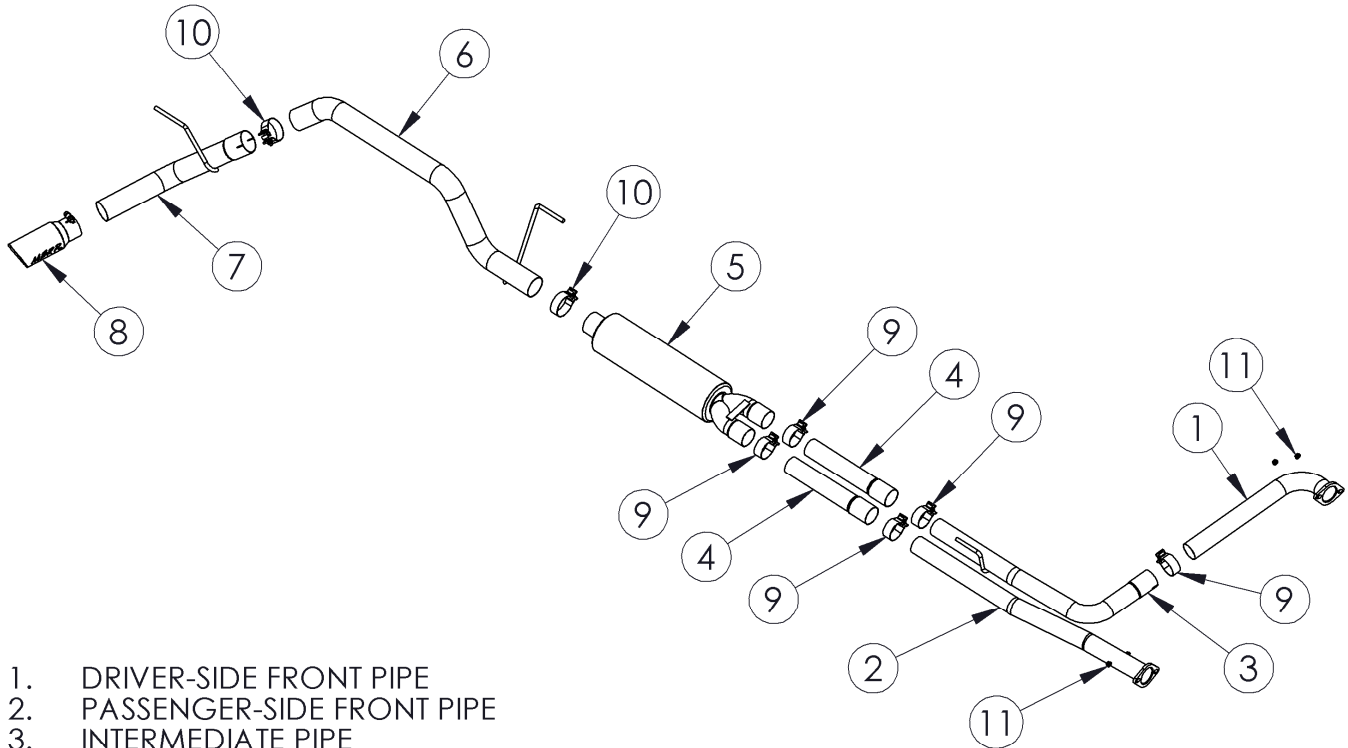

1. DRIVER-SIDE FRONT PIPE
2. PASSENGER-SIDE FRONT PIPE
3. INTERMEDIATE PIPE
4. EXTENSION PIPE
5. MUFFLER
6. OVER AXLE PIPE
7. TAIL PIPE
8. EXHAUST TIP
9. 2.5" BAND CLAMP (3PCS)
10. 3" BAND CLAMP (2PCS)
11. 10mm FLANGE NUT (4PCS)

## PLEASE READ BEFORE STARTING INSTALLATION

While MBRP Inc. has made every effort to ensure that all components of this system are of superior quality and properly packaged, it is the installer's responsibility to ensure the following before removal of the factory exhaust:

- that ALL components shown above are present.
- that ALL mating components fit together.
- that there are no damaged components.
- that the system you have purchased is appropriate for your vehicle year, model and configuration.
- that the system will not interfere with any modifications previously installed or planned.
- that you have read and understand these instructions.

If you have any questions or are uncertain about any aspect of the installation of this system to your vehicle please contact your dealer before commencing installation.

## Removal of Stock System

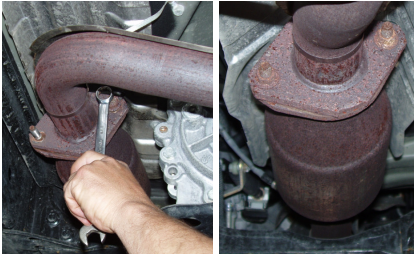

Figure 1

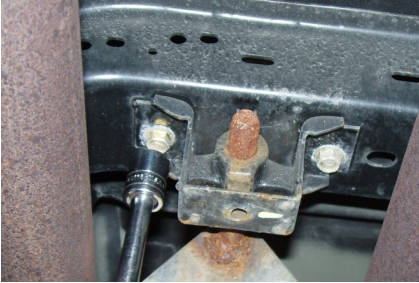

Figure 2



Figure 3



Figure 4



Figure 5

1. Apply a penetrating lubricant liberally to all exhaust fasteners, hangers and rubber insulators.
2. Remove the nuts from the exhaust flanges behind the catalytic converters. **Refer to Figure 1.**
3. Remove the front exhaust hanger from the vehicle frame (it will be reused). **Refer to Figure 2.**
4. Lubricate, then remove the hardware from the rearmost exhaust hanger. Keep for reinstallation. **Refer to Figure 3.**
5. The exhaust can now be removed in one piece by sliding it rearwards out of the hanger above the muffler, then bringing the front down and the tail forward, over the rear axle. This will require two people. If a second person is not present, remove the tail pipe by loosening the clamp behind the muffler, and then remove the front section.

## Installation of MBRP Inc. Performance Exhaust

1. Install the **Driver-Side Front Pipe** using the OEM gasket and existing hardware. The nuts can be replaced with the **10mm Flange Nuts**. Leave the hardware loose enough for some adjustment. **Refer to Figure 4.**
2. Slide a **2 1/2" Clamp** over the **Intermediate Pipe** and install it onto the **Driver-Side Front Pipe**. **Refer to Figure 5.**
3. Slide the existing factory hanger onto the **Intermediate Pipe** hanger and reattach it to the vehicle. **Refer to Figure 6.**
4. Install the **Passenger-Side Front Pipe** using the OEM gasket and existing hardware. The nuts can be replaced with the **10mm Flange Nuts**. Leave the hardware loose enough for some adjustment.
5. For Crew Cab (151.6" wheelbase) trucks, slide two **2 1/2" Clamps** onto the **Extension pipes** and attach them to the **Passenger-Side Front Pipe** and the **Intermediate Pipe**. **Refer to Figure 7.** For King Cab and Single Cab (139.8" wheelbase) configurations, the **Extension Pipes** are not used.



Figure 6



Figure 7



Figure 8



Figure 9



Figure 10

6. Slide two **2 ½" Clamps** onto the **Muffler** inlets and attach it to the **Extension Pipes** (or **Intermediate Pipe** and **Passenger-Side Front Pipe** for 139.8" wheelbases). Do not fully tighten the clamps yet. **Refer to Figure 7.**

7. Slide a **3" Clamp** over the outlet side of the **Muffler**. Position the **Over Axle Pipe** over the axle and loosely attach it to the **Muffler**. Install the **Over Axle Pipe** hanger into the factory rubber insulator. **Refer to Figure 8.**

8. Slide a **3" Band Clamp** over the **Tail Pipe** and install it onto the **Over Axle Pipe**. Slide the **Tail Pipe** hanger into the rearmost rubber insulator and reattach it to the frame. **Refer to Figure 9.**

9. Install and adjust the **Exhaust Tip** to suit. Using an 8mm Allen wrench, tighten the lock bolt located on the **Exhaust Tip**. **Refer to Figure 10.**

10. Align the exhaust as required. Starting at the front of the exhaust, tighten all clamps and connections.

11. Check along the entire length of the exhaust system to ensure that there is adequate clearance around the spare tire, fuel and brake lines, and any wiring. If any interference is detected, relocate or adjust.



**Congratulations!** You are ready to begin experiencing the improved power, sound, and driving experience of your MBRP Inc. performance exhaust system. We know you will enjoy your purchase.