

# S5342

CAT BACK, 2.5" SINGLE SIDE EXHAUST  
2010-2018 TOYOTA 4-RUNNER 4.0L,  
2011-2016 LAND CRUISER PRADO

**MBRP**  
INC.  
PERFORMANCE EXHAUST

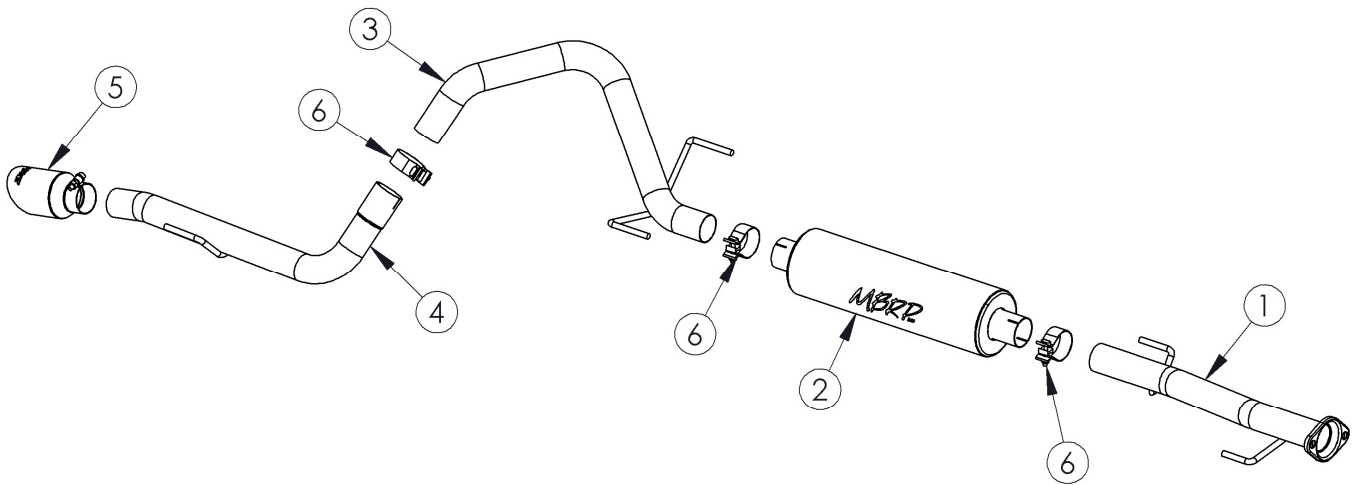

1. FRONT PIPE
2. MUFFLER
3. OVER-AXLE PIPE
4. TAIL PIPE
5. EXHAUST TIP
6. 2 1/2" CLAMP(3PCS)

## PLEASE READ BEFORE STARTING INSTALLATION

While MBRP Inc. has made every effort to ensure that all components of this system are of superior quality and properly packaged, it is the installer's responsibility to ensure the following before removal of the factory exhaust:

- that ALL components shown above are present.
- that ALL mating components fit together.
- that there are no damaged components.
- that the system you have purchased is appropriate for your vehicle year, model and configuration.
- that the system will not interfere with any modifications previously installed or planned.
- that you have read and understand these instructions.

If you have any questions or are uncertain about any aspect of the installation of this system to your vehicle please contact your dealer before commencing installation.

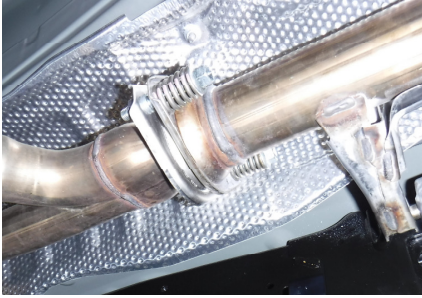

**Figure 1**



**Figure 2**



**Figure 3**

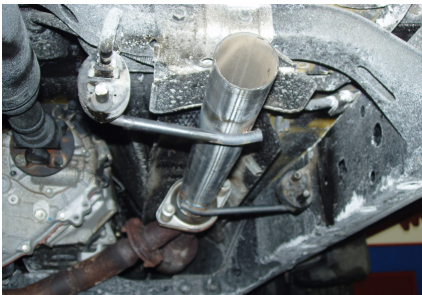

**Figure 4**



**Figure 5**

## Removal of Stock System

1. Apply a penetrating lubricant liberally to all exhaust fasteners, hangers, and rubber insulators.
2. Remove the bolts and springs holding the front flange together and disconnect the exhaust system. Do not discard this hardware; it will be reused during the installation. **Refer to Figure 1.**
3. Remove the hardware from the flange behind the muffler, then remove the rear hanger from the rubber insulator and remove the tail pipe from the vehicle. **Refer to Figures 2 & 3.** Removing the spare-tire heat shield will make removing the tail pipe easier.
4. Remove the muffler and front pipe hangers from the rubber insulators and remove the exhaust from the vehicle.

## Installation of MBRP Inc. Performance Exhaust

1. Insert the hangers on the **Front Pipe** into the rubber insulators and loosely install the **Front Pipe** flange to the stock flange using the existing hardware and springs. **Refer to Figure 4.**
2. Install the muffler onto the **Front Pipe** using a 2 1/2" Clamp. Do not fully tighten the clamp yet. **Refer to Figure 5.**
3. Slide a **2 1/2" Clamp** over the outlet side of the Muffler. Position the **Over-Axle Pipe** over the axle (**Refer to Figure 6**) and insert it into the muffler. Insert the **Over-Axle Pipe** hangers into the factory rubber insulators. Do not fully tighten the clamp yet.
4. Slide a **2 1/2" Clamp** over the **Tail Pipe** and install it onto the **Over-Axle Pipe** (do not fully tighten), then insert the **Tail Pipe** hanger into the rear rubber insulator. **Refer to Figure 7.**
5. Install and adjust the **Exhaust Tip** to suit. **Refer to Figure 8.**
6. Align the exhaust as required, then, starting at the front of the exhaust, tighten all clamps and connections.



**Figure 6**



**Figure 7**



**Figure 8**

7. Replace the spare-tire heat shield if it was removed.

8. Check along the whole length of the exhaust system to ensure that there is adequate clearance around the spare tire, fuel and brake lines or any wiring. If any interference is detected relocate or adjust.

9. Check along the whole length of the exhaust system to ensure that there is adequate clearance around the spare tire, fuel and brake lines or any wiring. If any interference is detected relocate or adjust.



**Congratulations!** You are ready to begin experiencing the improved power, sound, and driving experience of your MBRP Inc. performance exhaust system. We know you will enjoy your purchase.