

# S5338P

SINGLE SIDE-EXIT EXHAUST  
2016 & UP, 3.5L TOYOTA TACOMA

**MBRP**  
INC.  
PERFORMANCE EXHAUST

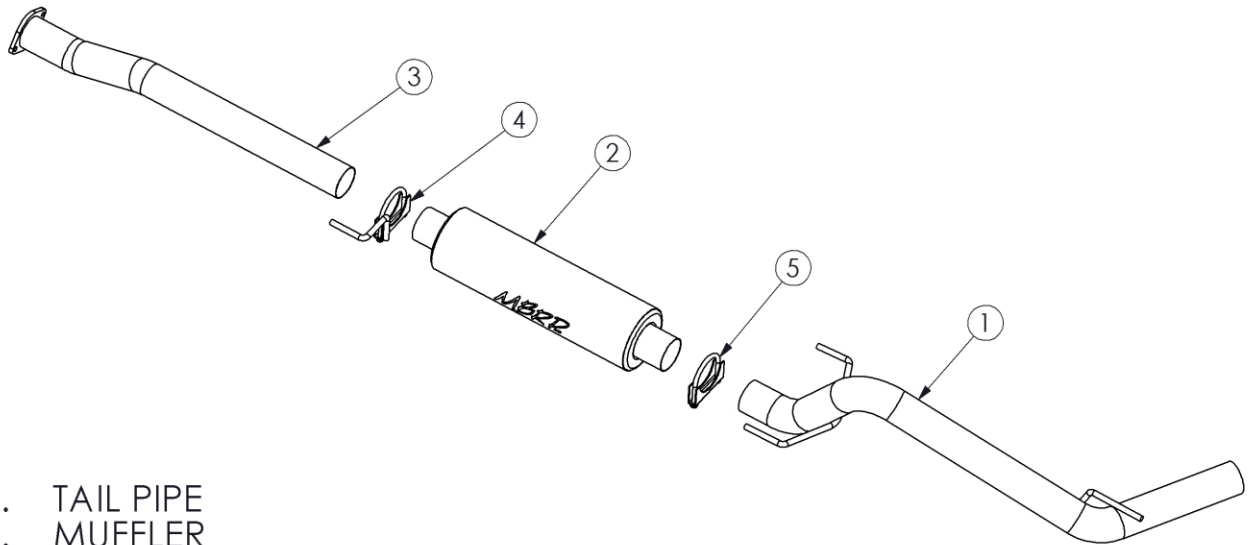

1. TAIL PIPE
2. MUFFLER
3. FRONT PIPE
4. 3" HANGER CLAMP
5. 3" CLAMP

## PLEASE READ BEFORE STARTING INSTALLATION

**While MBRP Inc. has made every effort to ensure that all components of this system are of superior quality and properly packaged, it is the installer's responsibility to ensure the following before removal of the factory exhaust:**

- that ALL components shown above are present.
- that ALL mating components fit together.
- that there are no damaged components.
- that the system you have purchased is appropriate for your vehicle year, model and configuration.
- that the system will not interfere with any modifications previously installed or planned.
- that you have read and understand these instructions.

If you have any questions or are uncertain about any aspect of the installation of this system to your vehicle please contact your dealer before commencing installation.

### **Removal of Stock System:**

1. Apply a penetrating lubricant liberally to all exhaust fasteners, hangers and rubber insulators.
2. Remove the bolts from the rear flange of the y-pipe. Do not discard the bolts as they will be reused for the installation.
3. Remove the hangers from the rubber isolators and remove the stock muffler and tail pipe. Retain the gasket from the y-pipe for reuse.



**Figure 1**



**Figure 2**



**Figure 3**

### **Installation of MBRP Inc. Performance Exhaust:**

1. Beginning with the **Front Pipe**, attach it to the Y-pipe using the bolts that were previously removed. **Refer to Figure 1.** The **Front Pipe** does not require cutting to fit 140.6" wheelbase trucks. For 127.4" wheelbase trucks, approximately 13 1/4" needs to be cut off from the end of the pipe without the flange. (**Installation tip:** Temporarily hang the **Muffler** and the **Front Pipe** in place and measure to the Y-pipe to verify the length required).
2. Loosely place the **3" Hanger Clamp** over the end of the **Front Pipe** and install the hanger into the factory rubber isolator.
3. Install the **Muffler** onto the front pipe, leaving the clamps loose. **Refer to Figure 2.** Place the **3" Clamp** over the muffler outlet.
4. Place the **Tail Pipe** over the rear axle and install it by inserting the pipe into the **Muffler** and the hangers into the factory isolators. Do not fully tighten the **3" Clamp** yet. **Refer to Figure 3.**
5. Make sure that the exhaust is properly in place before tightening clamps. Start at the front of the exhaust system and begin tightening all connections.

**Congratulations!** You are ready to begin experiencing the improved power, sound and driving excitement of your *MBRP Inc.* performance exhaust system. We know you will enjoy your purchase.