

# S5322

2005-2013 TOYOTA TACOMA 4.0L  
EC/CC, CAT BACK, SINGLE TURN  
DOWN

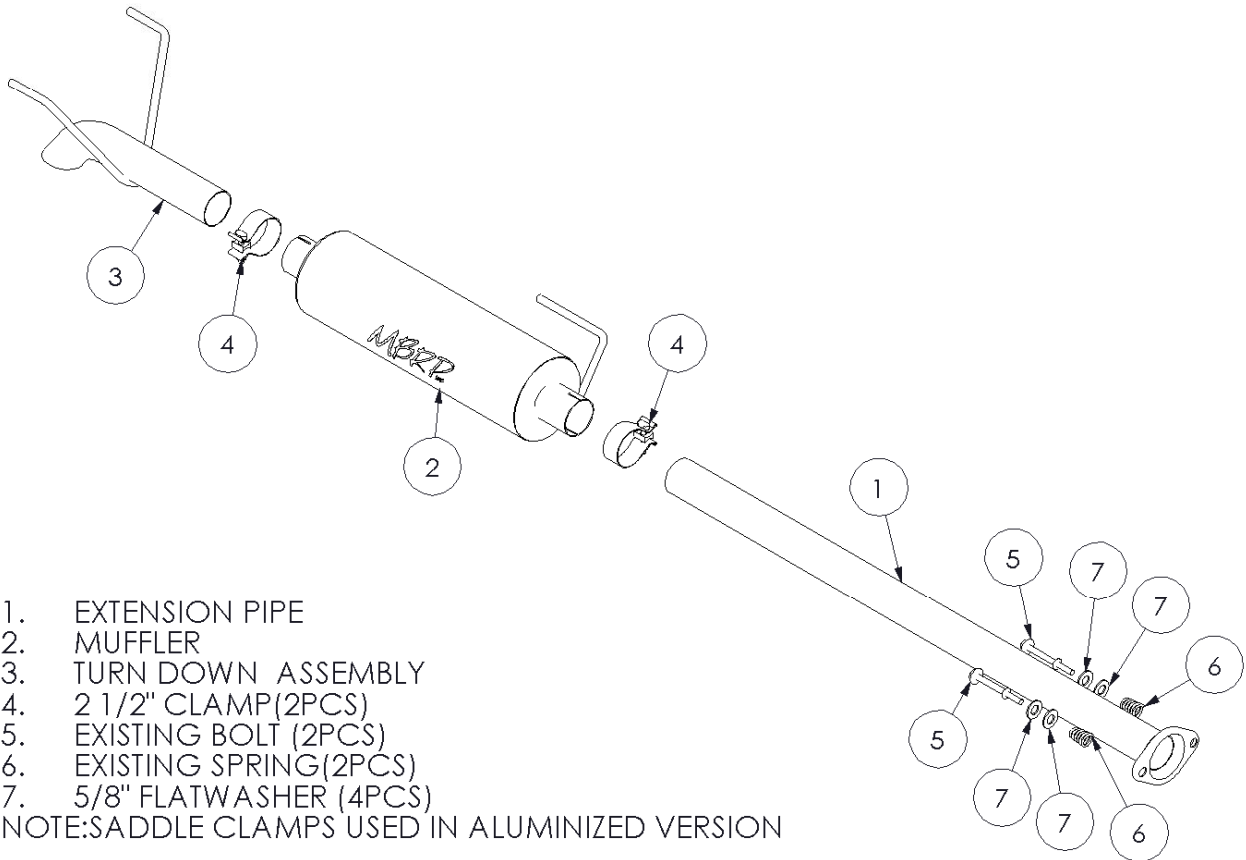

1. EXTENSION PIPE
2. MUFFLER
3. TURN DOWN ASSEMBLY
4. 2 1/2" CLAMP (2PCS)
5. EXISTING BOLT (2PCS)
6. EXISTING SPRING (2PCS)
7. 5/8" FLATWASHER (4PCS)

NOTE: SADDLE CLAMPS USED IN ALUMINIZED VERSION

## PLEASE READ BEFORE STARTING INSTALLATION

While MBRP Inc. has made every effort to ensure that all components of this system are of superior quality and properly packaged, it is the installer's responsibility to ensure the following before removal of the factory exhaust:

- that ALL components shown above are present.
- that ALL mating components fit together.
- that there are no damaged components.
- that the system you have purchased is appropriate for your vehicle year, model and configuration.
- that the system will not interfere with any modifications previously installed or planned.
- that you have read and understand these instructions.

If you have any questions or are uncertain about any aspect of the installation of this system to your vehicle please contact your dealer before commencing installation.



**Figure 1**



**Figure 2**



**Figure 3**



**Figure 4**



## Removal of Stock System

1. Apply a penetrating lubricant liberally to all exhaust fasteners, hangers and rubber insulators.
2. Remove the bolts and springs holding the front flange together and disconnect exhaust system. Do not discard this hardware as it is used for the installation. **Refer to Figure 1.**
3. Remove the hangers from the rubber insulators and remove the exhaust from the vehicle. If a hoist or hydraulic lift is not being used the tail pipe may need to be cut to clear the rear axle. **Refer to Figure 2.**

## Installation of MBRP Inc. Performance Exhaust:

1. Slide two of the **5/8" Flatwashers** over the bolts previously removed from the flange and then slide the springs over the bolts. Now loosely attach the **Extension Pipe** to the flange using the fasteners. **Refer to Figure 3.**  
Note: The **Extension Pipe** will need to be trimmed on some models. Refer to the illustration below.

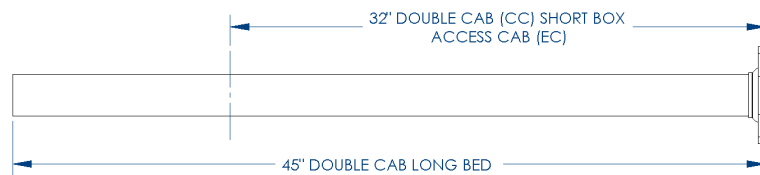

2. Install the **Muffler** onto **Extension Pipe** using one of the **2 1/2" Clamps**. Then install the hanger into the factory rubber insulator, do not tighten the clamp at this time. **Refer to Figure 4.**
3. Slide a **2 1/2" Clamp** over the outlet side of the **Muffler**. Position the **Turn Down Assembly** using the existing rubber insulators and loosely attach it to the Muffler.
4. Align the exhaust as required. Starting at the front of the exhaust, tighten all clamps and connections. Check along the whole length of the exhaust system to ensure that there is adequate clearance from fuel and brake lines or any wiring. If any interference is detected relocate or adjust.

**Congratulations!** You are ready to begin experiencing the improved power, sound and driving excitement of your MBRP Inc. performance exhaust system. We know you will enjoy your purchase.