

# S5306

TOYOTA TUNDRA 4.7L (2007-08) / 5.7L (2007-09), DOUBLE CAB STANDARD BED, CREW MAX SHORT BED, DUALS SPLIT SIDE

**MBRP**  
INC.  
PERFORMANCE EXHAUST

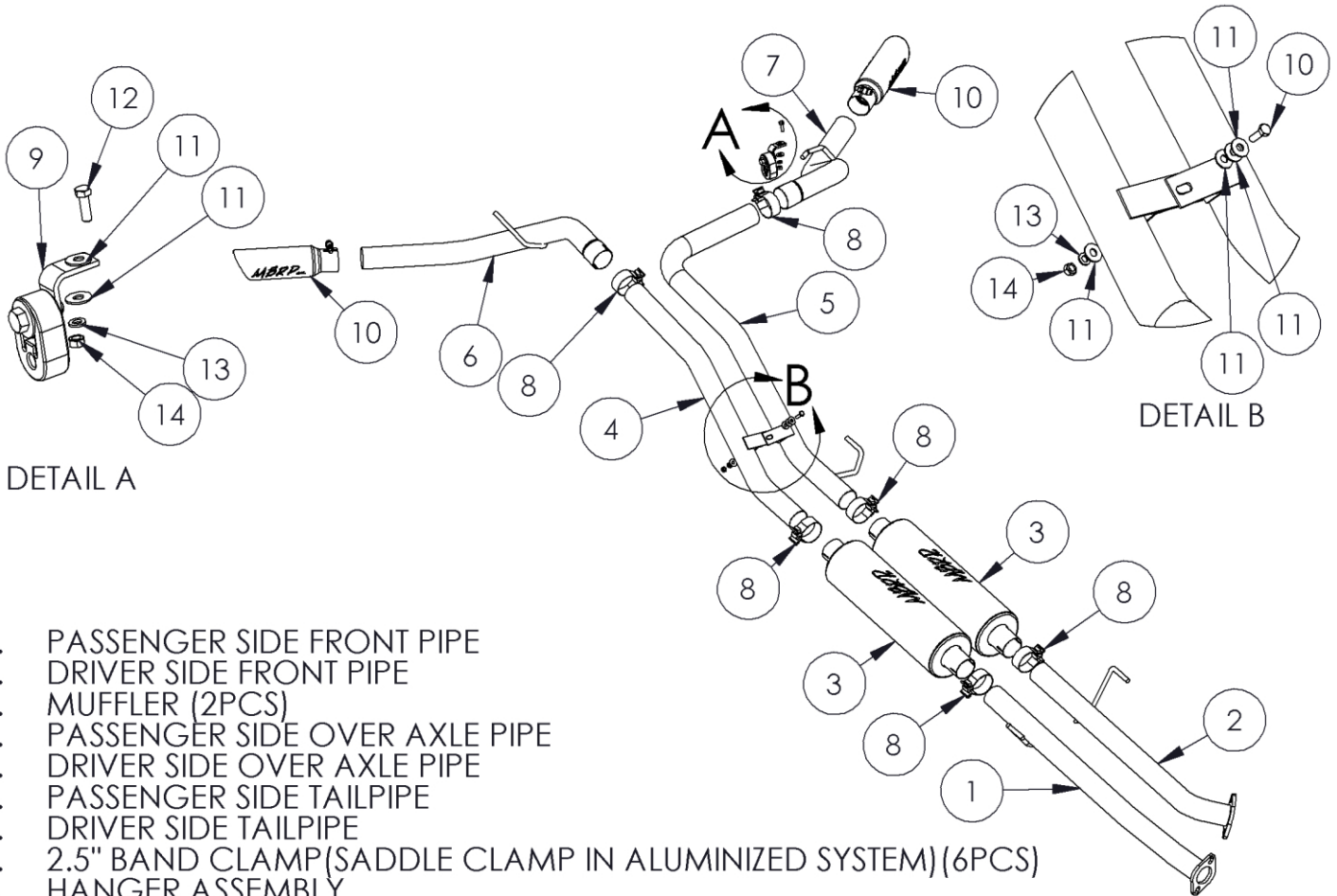

DETAIL A

DETAIL B

1. PASSENGER SIDE FRONT PIPE
2. DRIVER SIDE FRONT PIPE
3. MUFFLER (2PCS)
4. PASSENGER SIDE OVER AXLE PIPE
5. DRIVER SIDE OVER AXLE PIPE
6. PASSENGER SIDE TAILPIPE
7. DRIVER SIDE TAILPIPE
8. 2.5" BAND CLAMP (SADDLE CLAMP IN ALUMINIZED SYSTEM) (6PCS)
9. HANGER ASSEMBLY
10. 3/8" x 1" HEX BOLT (2PCS)
11. 3/8" FLAT WASHER (6PCS)
12. 3/8" LOCK WASHER (2PCS)
13. 3/8" NUT (2PCS)
14. EXHAUST TIP (2PCS)

## PLEASE READ BEFORE STARTING INSTALLATION

While MBRP Inc. has made every effort to ensure that all components of this system are of superior quality and properly packaged, it is the installer's responsibility to ensure the following before removal of the factory exhaust:

- that ALL components shown above are present.
- that ALL mating components fit together.
- that there are no damaged components.
- that the system you have purchased is appropriate for your vehicle year, model and configuration.
- that the system will not interfere with any modifications previously installed or planned.
- that you have read and understand these instructions.

If you have any questions or are uncertain about any aspect of the installation of this system to your vehicle please contact your dealer before commencing installation.

## TOYOTA TUNDRA

### 4.7L & 5.7L DOUBLE CAB STANDARD BED, CREW MAX SHORT BED

#### Removal of stock system:

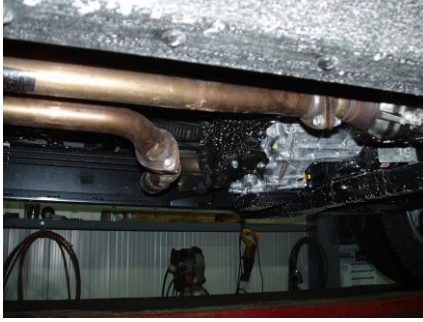

**Figure 1**



**Figure 2**



**Figure 3**



**Figure 4**

1. Apply a penetrating lubricant liberally to all exhaust fasteners, hangers and rubber insulators.

2. Remove hardware from stock extension pipes. Keep for reinstallation. **Refer to Figure 1.**

3. Remove exhaust from rubber insulators. **Refer to Figure 2.**

4. Remove the exhaust from the rearmost hanger. Leave the rubber insulators on the truck for installation. **Refer to Figure 3.**

#### Installation of MBRP Inc. Performance Exhaust:

1. Install the **Driver Side Front Pipe**, reusing the existing hardware and attaching the hanger to the existing rubber insulator. Leave the hardware loose enough for some adjustment.

**Refer to Figure 4.**



**Figure 5**

2. Install the **Passenger Side Front Pipe** reusing the existing hardware. Leave the hardware loose enough for some adjustment. Refer to **Figure 5**.



**Figure 6**

3. Slide **2.5" Clamps** over the **Passenger Side Front Pipe** and the **Driver Side Front Pipe**. Install the **Mufflers** onto the **Driver Side Front Pipe** and then the **Passenger Side Front Pipe**. Refer to **Figure 6**.



**Figure 7**

4. Slide a **2.5" Clamp** over the outlet side of the driver's side **Muffler**. Position the **Driver Side Over Axle Pipe** and loosely attach it to the **Muffler**. Install the **Driver Side Over Axle Pipe** hanger into the factory rubber insulator. Refer to **Figure 7**.

5. Slide a **2.5" Clamp** over the **Driver Side Tail Pipe** and install onto the **Driver Side Over Axle Pipe**. Install the **Hanger Assembly** onto the **Driver Side Tail Pipe** and install to the frame using the fastener provided. Refer to **Figures 8, 9 and Detail A on Page 1**.



**Figure 8**



**Figure 9**



**Figure 10**

7. Slide a **2.5" Clamp** over the outlet of the passenger side **Muffler**. Position the **Passenger Side Over Axle Pipe** over the axle and loosely attach it to the **Muffler**. Loosely attach to the **Driver Side Over Axle Pipe** using hardware provided. **Refer to Figure 10.**

Note, additional **3/8" Flat Washers** are provided in case spacing is required for adjustments.



**Figure 11**

8. Slide the **Passenger Side Tail Pipe** onto the **Passenger Side Over Axle Pipe** installing the hanger to the existing rubber insulator. **Refer to Figure 11.**

9. Install and adjust the **Exhaust Tips** to suit. Using a 17mm wrench tighten the lock bolt located on each **Exhaust Tip**.

10. Align the exhaust as required. Starting at the front of the vehicle exhaust, tighten all clamps and connections.

11. Check along the whole length of the exhaust system to ensure that there is adequate clearance around the spare tire, fuel and brake lines.



**Congratulations!** You are ready to begin experiencing the improved power, sound and driving experience of your MBRP Inc. performance exhaust system. We know you will enjoy your purchase.