

S5265

2017+ Ford F150 Raptor 3.5L EcoBoost
3" Dual Cat-Back Street

MBRP
INC.
PERFORMANCE EXHAUST

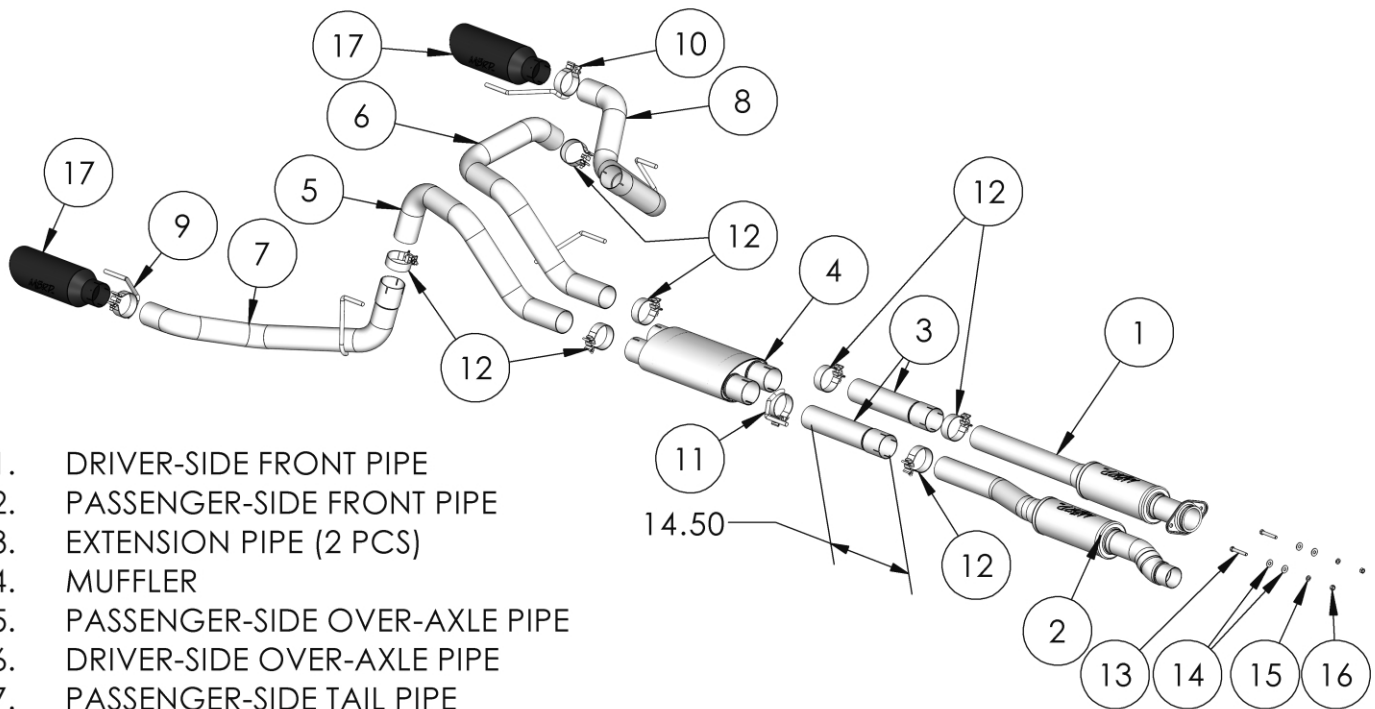

1. DRIVER-SIDE FRONT PIPE
2. PASSENGER-SIDE FRONT PIPE
3. EXTENSION PIPE (2 PCS)
4. MUFFLER
5. PASSENGER-SIDE OVER-AXLE PIPE
6. DRIVER-SIDE OVER-AXLE PIPE
7. PASSENGER-SIDE TAIL PIPE
8. DRIVER-SIDE TAIL PIPE
9. PASSENGER-SIDE TIP HANGER CLAMP
10. DRIVER-SIDE TIP HANGER CLAMP
11. MUFFLER HANGER CLAMP
12. 3" BAND CLAMP (7 PCS)
13. 3/8" X 2.5" BOLT (2 PCS)
14. 3/8" FLAT WASHER (4 PCS)
15. 3/8" LOCK WASHER (2 PCS)
16. 3/8" NUT (2 PCS)
17. TIP (2 PCS)

PLEASE READ BEFORE STARTING INSTALLATION

While MBRP Inc. has made every effort to ensure that all components of this system are of superior quality and properly packaged, it is the installer's responsibility to ensure the following before removal of the factory exhaust:

- that ALL components shown above are present.
- that ALL mating components fit together.
- that there are no damaged components.
- that the system you have purchased is appropriate for your vehicle year, model and configuration.
- that the system will not interfere with any modifications previously installed or planned.
- that you have read and understand these instructions.

Removal of Stock System:



Figure 1

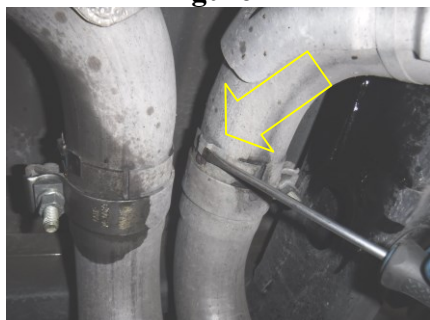

Figure 2



Figure 3

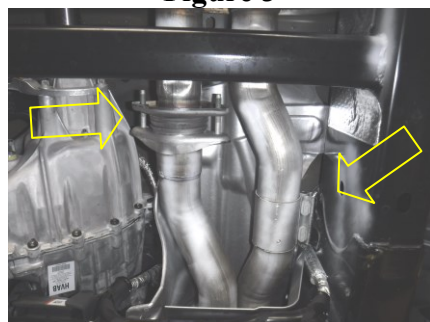

Figure 4

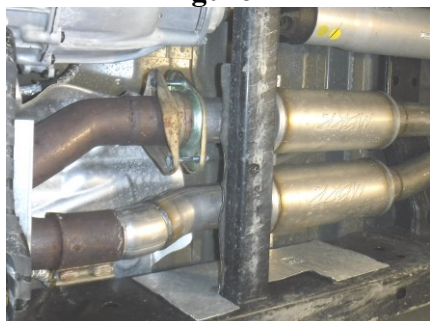

Figure 5

1. Apply a penetrating lubricant liberally to all hangers, hardware and rubber isolators and lower the spare tire to provide clearance for removing the factory tail-pipes.

2. Remove tip hangers from vehicle, both sides.

Refer to Figure 1.

3. Loosen the factory tail-pipe clamps and pry open the factory spring locks.

Refer to Figure 2.

4. Remove the tail-pipes from the vehicle. You may need to remove the driver-side isolator from the frame.

5. Loosen the two clamps ahead of the muffler. Remove the factory muffler assembly from the hangers and remove from the vehicle.

Refer to Figure 3.

6. Remove the factory front resonator bolts and loosen the sleeve clamp nuts. Remove the factory front resonator from the vehicle.

Refer to Figure 4.

Installation of MBRP Inc. Performance Exhaust:

1. Loosely install the **Passenger-Side Front Pipe** using the factory coupler clamp. You can modify the coupler to have the nuts facing down by adding a notch in the clamp to the side opposite the factory notch.

Refer to Figure 5.

2. Loosely install the **Driver-Side Front Pipe** using the supplied 3/8" Hardware.

Refer to Figure 5.



Figure 6

3. ONLY SuperCrew models require the two **Extension Pipes** to be installed onto the **Front Pipes** using **3” Clamps**. (SuperCrew model shown.)

Refer to Figure 6.

4. Place the **Muffler Hanger Clamp** onto the outer **Muffler** inlet and one **3” Clamp** onto the **Driver-Side Front Pipe** (or **Extension Pipe** if required).

Refer to Figure 7.



Figure 7

5. Install the **Muffler** onto the pipes and the **Muffler Hanger Clamp** into the factory rubber isolator at the same time.

Refer to Figure 8.

6. Using a **3” Clamp**, install the **Driver-Side Over-Axle Pipe** into the **Muffler** and into the factory isolator.

Refer to Figure 9.



Figure 8

7. Install the **Driver-Side Tail Pipe** onto the **Driver-Side Over-Axle Pipe** and into the factory isolator. It may be necessary to remove the factory isolator from the frame if not done so during system removal. Reinstall the factory isolator.

Refer to Figure 10.

8. Using a **3” Clamp**, very loosely (do not tighten clamp) install the **Passenger-Side Tail Pipe** onto the **Passenger-Side Over-Axle Pipe** and install into the **Muffler** (using a **3” Clamp**) and factory isolator as an assembly.

Refer to Figures 11 and 12.

9. Place the **Driver-Side Tip Hanger Clamp** onto the **Driver-Side Tail Pipe** and place the factory tip hanger onto the **Driver-Side Tip Hanger Clamp**.

Refer to Figure 13.

10. Place the **Exhaust Tip** onto the **Driver-Side Tail Pipe** and into the **Driver-Side Tip Hanger Clamp**.

Refer to Figure 14.

11. Reinstall the factory tip hanger using the original hardware. Center the tip in the bumper opening and adjust to your liking. The tips may need re-alignment as you tighten up the rest of the system.

There is adjustment in the factory tail pipe hanger as well as the **Hanger Clamp**. Some patience and care are required to get the alignment perfect.

Refer to Figure 15.



Figure 9



Figure 10



Figure 11

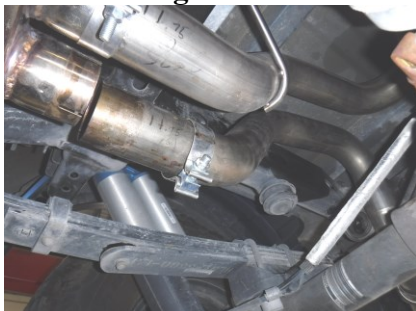

Figure 12



Figure 13



Figure 14



Figure 15

12. Repeat steps 9 through 11 for the passenger-side components.

13. Align all the components and partially tighten all clamps and hardware to ensure the **Exhaust Tips** are centered in the bumper opening, and there is clearance around the body, frame and bumper. Once everything is aligned, completely tighten all **Clamps** and **Hardware**.

14. Check along the whole length of the exhaust system to ensure that there is adequate clearance around the frame, body, running boards, fuel and brake lines or any wiring. If any interference is detected, relocate or adjust.



Congratulations! You are ready to begin experiencing the improved power, sound and driving experience of your *MBRP Inc.* performance exhaust system. We know you will enjoy your purchase.