

S5247

17-UP FORD F250/F350, 6.2L,
SUPER/CREW CAB, CAT BACK, 4" SINGLE
SIDE

MBRP
INC.
PERFORMANCE EXHAUST

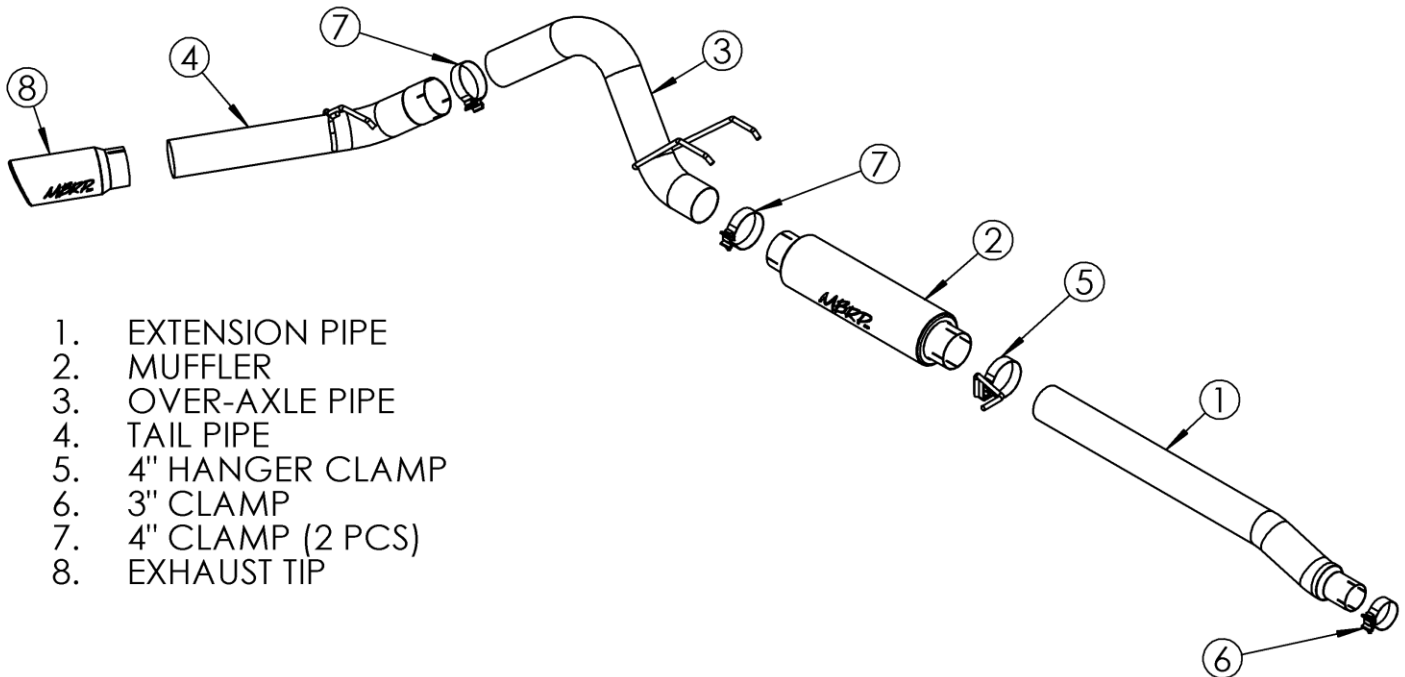

1. EXTENSION PIPE
2. MUFFLER
3. OVER-AXLE PIPE
4. TAIL PIPE
5. 4" HANGER CLAMP
6. 3" CLAMP
7. 4" CLAMP (2 PCS)
8. EXHAUST TIP

PLEASE READ BEFORE STARTING INSTALLATION

While MBRP Inc. has made every effort to ensure that all components of this system are of superior quality and properly packaged, it is the installer's responsibility to ensure the following before removal of the factory exhaust:

- that ALL components shown above are present.
- that ALL mating components fit together.
- that there are no damaged components.
- that the system you have purchased is appropriate for your vehicle year, model and configuration.
- that the system will not interfere with any modifications previously installed or planned.
- that you have read and understand these instructions.

If you have any questions or are uncertain about any aspect of the installation of this system to your vehicle please contact your dealer before commencing installation.

Removal of Stock System:



Figure 1

1. Apply a penetrating lubricant liberally to all exhaust fasteners, hangers and rubber insulators.

2. Loosen the clamp behind factory resonator.
Refer to Figure 1.



Figure 2

3. Remove the nuts from the stock hanger clamp.
Refer to Figure 2.

4. Remove the hangers from the rubber insulators and remove the exhaust from the vehicle.



Figure 3

Installation of MBRP Inc. Performance Exhaust:

1. Install the **Extension Pipe** to the vehicle using the **3" Clamp** provided.
Refer to Figure 3.

Note: the extension pipe may need to be cut.
Refer to the illustration below.



Figure 4

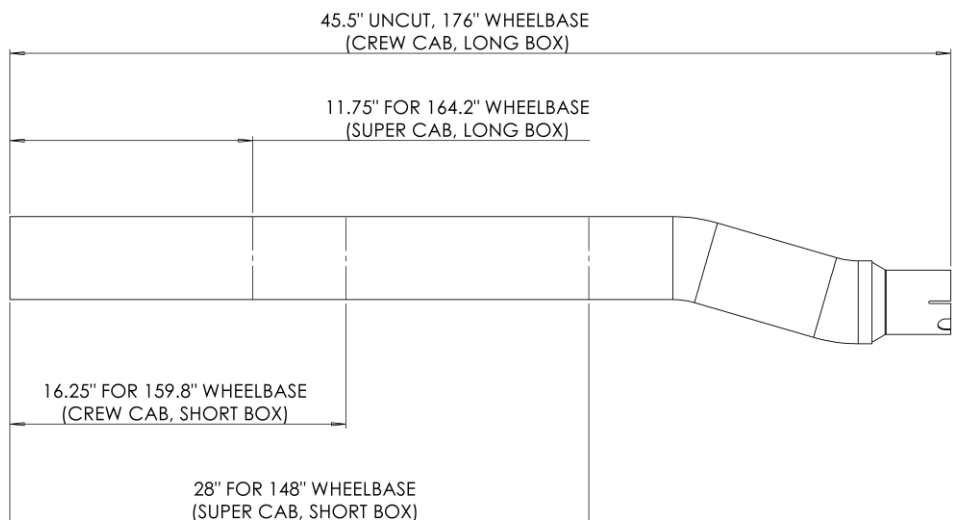

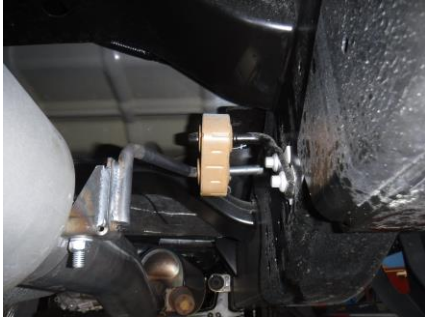

Figure 5

2. Install the **Muffler** onto the **Extension Pipe** using the **4" Hanger Clamp**. Refer to Figures 4 & 5.

3. Place the hangers of the **Over-Axle Pipe** into the existing rubber isolators. Loosely install the **Over-Axle Pipe** connecting it to the **Muffler** outlet and securing it with one of the **4" Clamps** provided.

Refer to Figure 6.



Figure 6

4. Place the hanger of the **Tail Pipe** into the existing rubber isolator. Loosely install the **Tail Pipe** connecting it to the **Over-Axle Pipe** and securing it with the remaining **4" Clamp**.

5. Install and adjust the **Exhaust Tip** to suit. Tighten the lock bolt on the **Exhaust Tip**.

Refer to Figure 7.



Figure 7

6. Align the exhaust as required. Starting at the front of the exhaust, tighten all clamps and connections.

7. Check along the whole length of the exhaust system to ensure that there is adequate clearance around the spare tire, fuel and brake lines or any wiring. If any interference is detected, relocate or adjust.

Congratulations! You are ready to begin experiencing the improved power, sound and driving excitement of your MBRP Inc. performance exhaust system. We know you will enjoy your purchase.



Figure 8