

S5246

2011-2013 FORD SUPER-DUTY
F250/350, SUPER CAB & CREW CAB
6.2L V8, CAT BACK, SINGLE

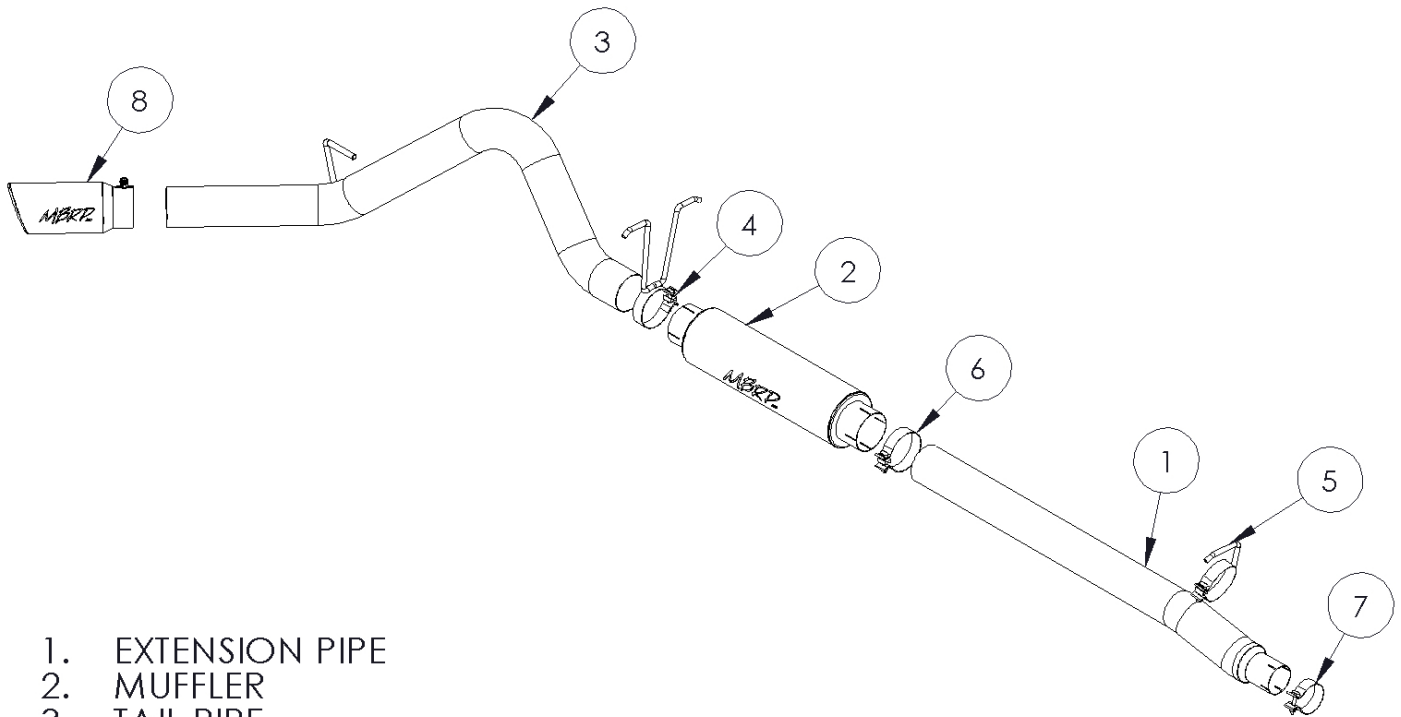

1. EXTENSION PIPE
2. MUFFLER
3. TAIL PIPE
4. 4" HANGER CLAMP
5. 4" HANGER CLAMP
6. 4" CLAMP
7. 3" CLAMP
8. EXHAUST TIP

NOTE: SADDLE CLAMPS ARE USED IN ALUMINIZED SYSTEMS

PLEASE READ BEFORE STARTING INSTALLATION

While MBRP Inc. has made every effort to ensure that all components of this system are of superior quality and properly packaged, it is the installer's responsibility to ensure the following before removal of the factory exhaust:

- that ALL components shown above are present.
- that ALL mating components fit together.
- that there are no damaged components.
- that the system you have purchased is appropriate for your vehicle year, model and configuration.
- that the system will not interfere with any modifications previously installed or planned.
- that you have read and understand these instructions.

If you have any questions or are uncertain about any aspect of the installation of this system to your vehicle please contact your dealer before commencing installation.



Figure 1

Removal of Stock System:

1. Apply a penetrating lubricant liberally to all exhaust fasteners, hangers and rubber insulators.
2. Loosen the clamp located rearward of the pipe **shown in Figure 1**.
3. Remove the hangers from the rubber insulators and remove the exhaust from the vehicle. **Refer to Figure 2.**



Figure 2



Figure 3

Installation of MBRP Inc. Performance Exhaust:

1. Install the Front Pipe to the vehicle using the **3" Clamp** provided. Attach the **Front Pipe** hanger to the existing rubber isolator. **Refer to Figure 3.**
Note: the front pipe made need trimming refer to the illustration.



Figure 4

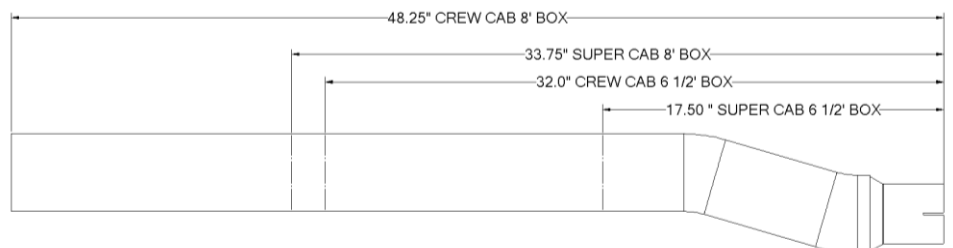



Figure 5

2. Slide a **4" Hanger Clamp** over the **Extension Pipe** if needed. It will not be required on some shorter wheelbase models. Install the **Muffler** onto the **Extension Pipe** using the **4" Clamp**. Install **4" Hanger Clamp** to outlet of the **Muffler**, place the hangers into the existing rubber isolators. **Refer to Figures 4 & 5.**



Figure 6

3. Loosely install the **Tail Pipe** connecting it to the **Muffler** outlet and securing it with the **4" Hanger Clamp**. **Refer to Figure 6.**

4. Install and adjust the **Exhaust Tip** to suit. Using a 17mm wrench tighten the lock bolt on the **Exhaust Tip**. **Refer to Figure 6.**



Figure 7

5. Align the exhaust as required. Starting at the front of the exhaust tighten all clamps and connections.

6. Check along the whole length of the exhaust system to ensure that there is adequate clearance around the spare tire, fuel and brake lines or any wiring. If any interference is detected relocate or adjust.

Congratulations! You are ready to begin experiencing the improved power, sound and driving excitement of your MBRP Inc. performance exhaust system.
We know you will enjoy your purchase.



Figure 8