

S5201

2015-2020 FORD F150,
5.0L, 3.5L ECOBOOST, 2.7L ECOBOOST,
EXCL. 2019-2020 F150 LIMITED 3.5L ECOBOOST
HIGH OUTPUT,
MUFFLER BYPASS, 3.0"

MBRP®

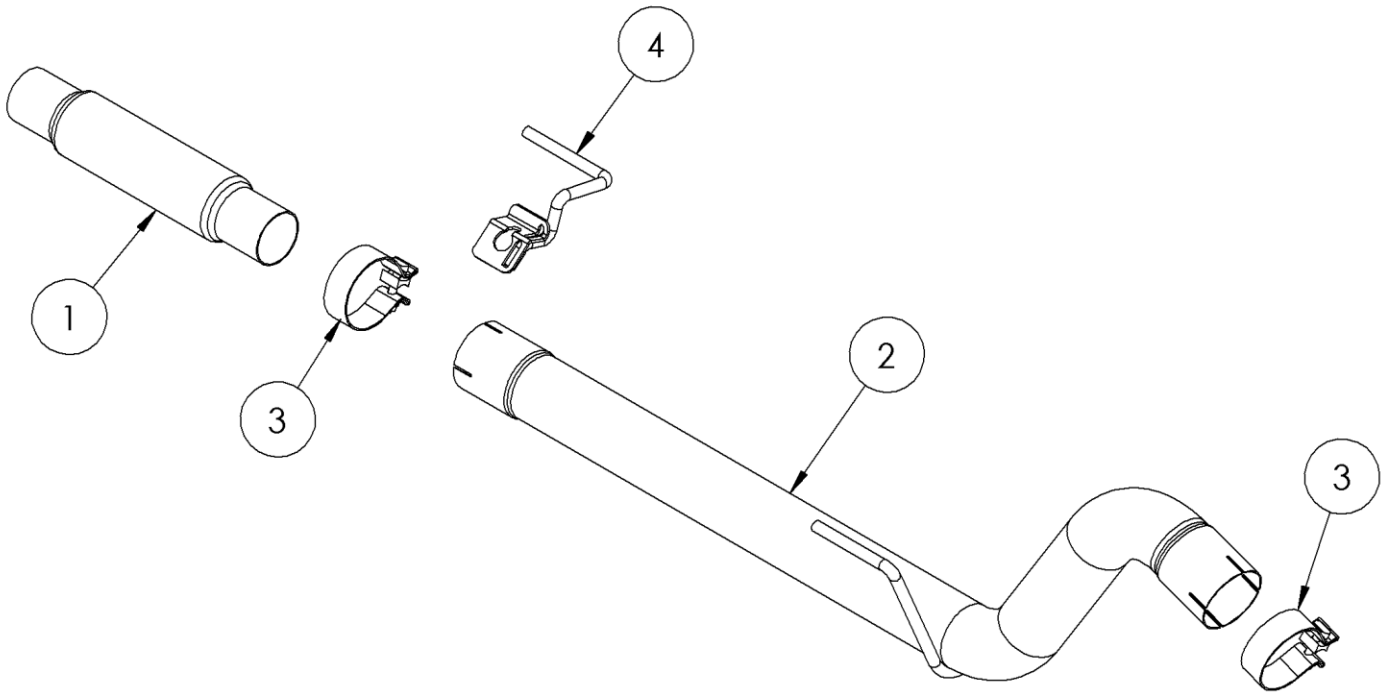

ITEM	DESCRIPTION	QTY
1	OEM ADAPTOR PIPE	1
2	OVER-AXLE PIPE	1
3	3.0" CLAMP	2
4	HANG TIGHT™ HANGER	1

PLEASE READ BEFORE STARTING INSTALLATION

While MBRP has made every effort to ensure that all components of this system are of superior quality and properly packaged, it is the installer's responsibility to ensure the following before removal of the factory exhaust:

- that ALL components shown above are present.
- that ALL mating components fit together.
- that there are no damaged components.
- that the system you have purchased is appropriate for your vehicle year, model and configuration.
- that the system will not interfere with any modifications previously installed or planned.
- that you have read and understand these instructions.

If you have any questions or are uncertain about any aspect of the installation of this system to your vehicle please contact your dealer before commencing installation.

MBRP

Removal of Stock System:



Figure 1

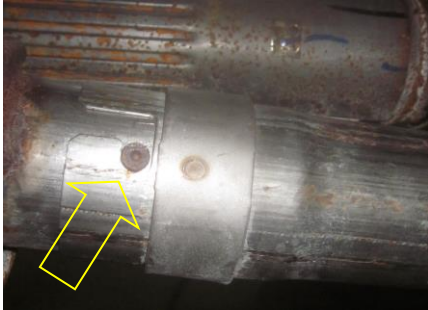

Figure 2

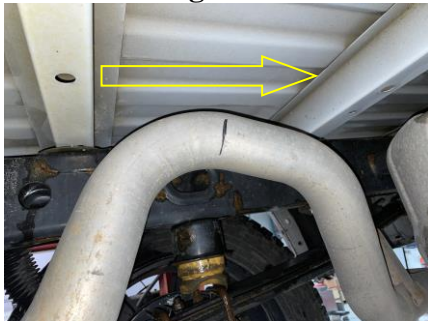

Figure 3



Figure 4

1. Apply a penetrating lubricant liberally to all hangers and rubber isolators. The exhaust may be cut on or off the vehicle, however, the factory exhaust will not be able to be removed if the vehicle is on the ground.

Refer to Step 6 for Cut Location.

2. Loosen the factory clamp in front of the muffler.

3. Loosen the factory extension pipe flange bolts.

Refer to Figure 1.

4. Rotate the factory extension pipe to release the factory muffler inlet locking boss.

Refer to Figure 2.

5. Remove the factory muffler assembly from the hangers and remove from the vehicle.

6. Cut the factory tail pipe from the rest of the exhaust at the start of the straight of the factory over-axle section (Arrow points to the rear of the vehicle).

Refer to Figure 3.

Installation of MBRP Performance Exhaust:

1. Install the **OEM Adaptor Pipe** into the factory front pipe. Ensure the pipe is a minimum of 2" into the factory expansion.

Refer to Figure 4.

2. Install the **Hang Tight™ Hanger** onto a **3.0" Band Clamp** using the procedure shown below. (Hang Tight™ Hanger not exactly as shown).

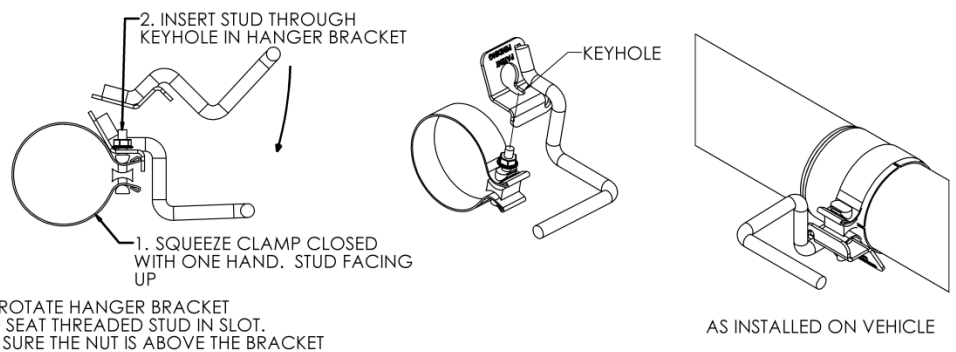

3. Install the **Hang Tight™ Hanger** clamp into the factory isolator and over the adaptor pipe.

Refer to Figure 5.

MBRP



Figure 5

4. Install the **Over-Axle Pipe** over the **Adaptor Pipe** and into the factory isolator. Loosely secure with the **Hang Tight™ Hanger** clamp previously installed.

Refer to Figure 6 and 7.



Figure 6

5. Install the factory tail pipe into the factory hanger and the **Over-Axle Pipe** using the **3.0" Band Clamp**.

Refer to Figures 7 and 8.



Figure 7

6. Tighten the flange bolts of the factory front pipe. Align the tail pipe to your preference. Align the edge of each band clamp with the edge of the joint it is connecting. Tighten all hardware and clamps, starting at the front and working rearward to secure the system. Check along the full length of the exhaust system to ensure there is adequate clearance for fuel lines, vent lines, brake lines, frame, bodywork, suspension, and any wiring, etc. If there is any interference detected, relocate, or adjust to provide adequate clearance. Ensure all clamp connections are secure and components are unable to rotate or slide. Band clamps require approximately 45 lb-ft (60 N-m) of torque. Verify clearances, system security and band clamp torque after 30-60 miles (50-100 km) of driving.



Figure 8

Congratulations! You are ready to begin experiencing the improved power, sound and driving experience of your **MBRP** Performance Exhaust system. We know you will enjoy your purchase.