

S5200

04-08 F150 4.6L 5.4L, EC/CC SB
CAT BACK SINGLE

MBRP
INC.
PERFORMANCE EXHAUST

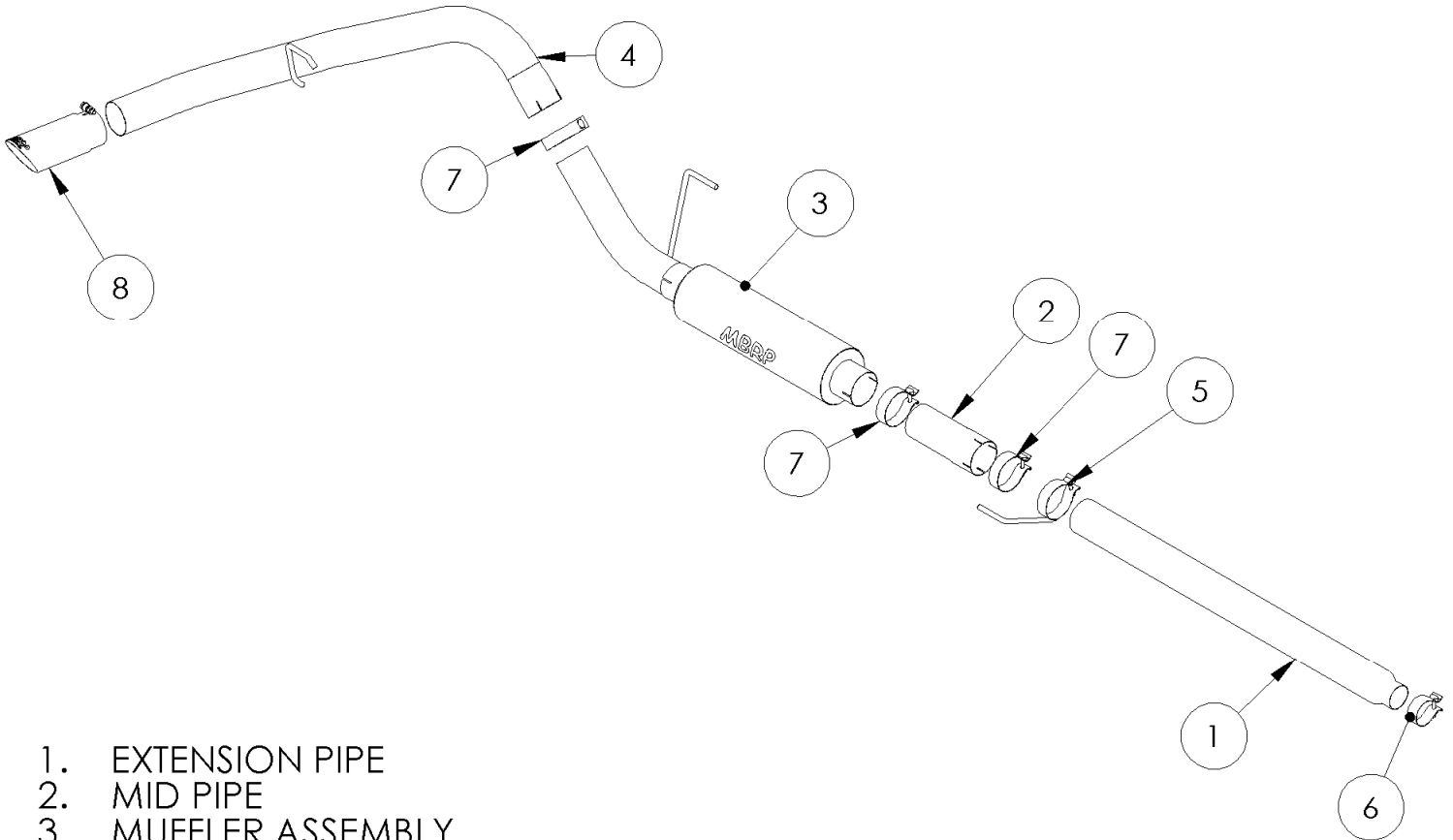

1. EXTENSION PIPE
2. MID PIPE
3. MUFFLER ASSEMBLY
4. TAIL PIPE
5. 3 1/2" HANGER CLAMP (SADDLE CLAMP IN ALUMINIZED SYSTEM)
6. 2 1/2" BAND CLAMP (SADDLE CLAMP IN ALUMINIZED SYSTEM)
7. 3 1/2" BAND CLAMP (SADDLE CLAMP IN ALUMINIZED SYSTEM)(3 PCS)
8. EXHAUST TIP

PLEASE READ BEFORE STARTING INSTALATION

While MBRP Inc. has made every effort to ensure that all components of this system are of superior quality and properly packaged, it is the installer's responsibility to ensure the following before removal of the factory exhaust:

- that ALL components shown above are present.
- that ALL mating components fit together.
- that there are no damaged components.
- that the system you have purchased is appropriate for your vehicle year, model and configuration.
- that the system will not interfere with any modifications previously installed or planned.
- that you have read and understand these instructions.

If you have any questions or are uncertain about any aspect of the installation of this system to your vehicle please contact your dealer before commencing installation.



PERFORMANCE EXHAUST

04-08 Ford F-150 4.6L / 5.4L (Excluding Extended Cab Long Bed)

Removal of stock system:

1. Apply a penetrating lubricant liberally to all exhaust fasteners, hangers and rubber insulators.
2. Loosen the clamp located behind the "Y" pipe at the slip joint.
3. Remove the hangers from the rubber insulators and remove the exhaust from the vehicle. If a hoist or hydraulic lift is not being used the tail pipe may need to be cut to clear the rear axle.

Installation of MBRP Inc. Performance Exhaust:

NOTE: This system DOES NOT require the removal of the spare tire.

1. Install the reduced end of the **Extension Pipe** over the factory exhaust system behind the "Y" pipe and install the **Muffler Assembly** onto the **Extension Pipe**. See the chart below for **Extension Pipe** modifications. Cut the **Extension Pipe** if required.

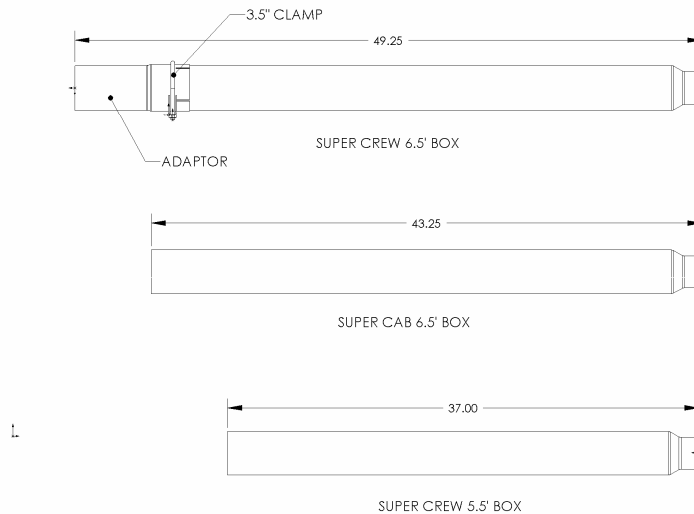

2. Install the **Muffler Assembly** onto the **Mid Pipe** and install the hanger into the factory rubber insulator located above the rear of the **Muffler**.
3. Feed the **Tail Pipe** over the axle and loosely attach it to the **Muffler Assembly**. Install the **Tail Pipe** hanger into the factory rubber insulator located directly above the hanger.
4. Install the **Hanger Clamp** on the pipe in front of **Muffler Assembly** and insert into the factory rubber insulator located on the frame.



PERFORMANCE EXHAUST

5. Install the mirror polished Exhaust Tip. It is recommended to install it at this point to assist with the final system alignment.
6. Install provided clamps to the pipe connections where required. Align the exhaust as required before tightening clamps.
7. Start at the front of the exhaust system and tighten all clamps and connections.
8. Check along the whole length of the exhaust system to ensure that there is adequate clearance around the spare tire, fuel and brake lines or any wiring. If any interference is detected relocate or adjust.



Congratulations! You are ready to begin enjoying the improved performance and driving experience of your MBRP Inc. Performance Exhaust system. We hope you enjoy your purchase.