

S5142

09-15 DODGE RAM 1500, 5.7L HEMI,
CAT BACK, 3" SINGLE SIDE

MBRP
INC.
PERFORMANCE EXHAUST

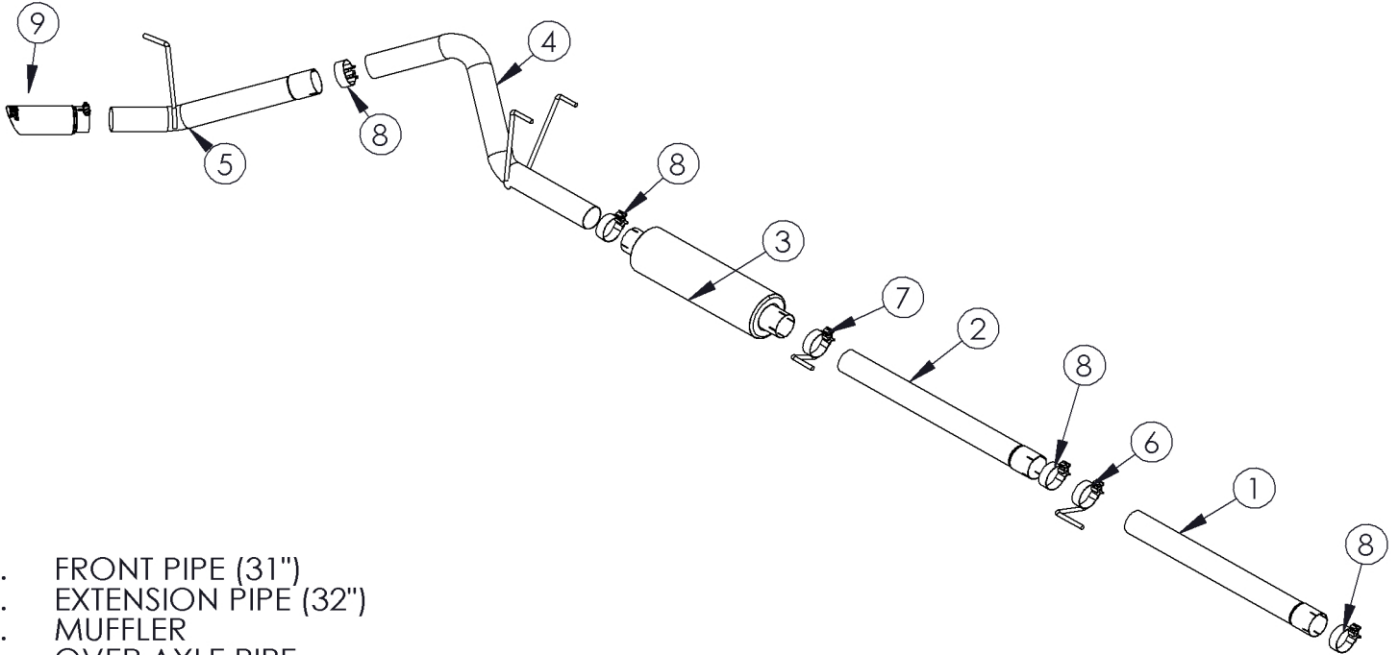

1. FRONT PIPE (31")
2. EXTENSION PIPE (32")
3. MUFFLER
4. OVER AXLE PIPE
5. TAIL PIPE
6. 3" HANGER CLAMP
7. 3" HANGER CLAMP
8. 3" CLAMP(3PCS)
9. EXHAUST TIP

NOTE: SADDLE CLAMPS USED IN ALUMINIZED VERSION

PLEASE READ BEFORE STARTING INSTALLATION

While MBRP Inc. has made every effort to ensure that all components of this system are of superior quality and properly packaged, it is the installer's responsibility to ensure the following before removal of the factory exhaust:

- that ALL components shown above are present.
- that ALL mating components fit together.
- that there are no damaged components.
- that the system you have purchased is appropriate for your vehicle year, model and configuration.
- that the system will not interfere with any modifications previously installed or planned.
- that you have read and understand these instructions.

If you have any questions or are uncertain about any aspect of the installation of this system to your vehicle please contact your dealer before commencing installation.

2009-2015 Dodge Ram 1500 5.7L HEMI

Removal of stock system:



Figure 1



Figure 2

1. Apply a penetrating lubricant liberally to all exhaust fasteners, hangers and rubber insulators.

2. Remove clamp just after the Y pipe. **Refer to Figure 1.**

3. Remove clamp from the rear of the muffler. **Refer to Figure 2.**

4. Remove the stock exhaust from the existing rubber isolators and remove the system from the vehicle.

Installation of MBRP Inc. Performance Exhaust:



Figure 3

1. Install **Front Pipe** over the existing Y using the **3" Clamp**. The **Front Pipe** will need to be cut depending on Cab Type. **Refer to Chart 1.** Leave the **3" Clamp** loose enough for adjustment. **Refer to Figure 4.** Note the front pipe will not be required on a regular cab short box.

Cab Type	Box Length	Wheel Base	Front Pipe Required	Cut Required = New Length
Regular	6'4"	120.5	No	N/A
Regular	8'	140.5	Yes	Yes = 23"
Quad Cab	6'4"	140.5	Yes	Yes = 23"
Crew Cab	5'7"	140.5	Yes	Yes = 23"
Crew Cab	6'4"	149.5	Yes	No = 31"

Chart 1



Figure 4

2. Slide a **3" Hanger Clamp** over the **Front Pipe**. Attach the hanger to the existing rubber insulator. Install the **Extension Pipe** to the **Front pipe** using the **3" Clamp**. **Refer to Figure 4.**



Figure 5

3. Install the second **3" Hanger Clamp** over the **Extension Pipe** and to the existing rubber isolator. **Refer to Figure 5.**

4. Slide the Muffler onto the Extension Pipe and attach it using the **3" Hanger Clamp**. **Refer to Figure 6.**



Figure 6

5. Attach the **Over Axle Pipe** hangers to the existing rubber insulators and to the outlet of the **Muffler**. **Refer to Figure 7.**

6. Install **Tail Pipe** to the **Over Axle Pipe** using a **3" Clamp**. Install and adjust the **Exhaust Tip** to suit. Using a 17mm wrench tighten the lock bolt located on the **Exhaust Tip**. **Refer to Figure 8.**

7. Align the exhaust as required. Starting at the front of the exhaust, tighten all clamps and connections.



Figure 7

8. Check along the whole length of the exhaust system to ensure that there is adequate clearance around the spare tire, fuel and brake lines or any wiring. If any interference is detected relocate or adjust.



Figure 8



Congratulations! You are ready to begin experiencing the improved power, sound and driving experience of your MBRP Inc. performance exhaust system. We know you will enjoy your purchase.