

S5074

09-12 CHEV COLORADO /
GMC CANYON, 5.3L V8,
EC/CC-SB, CAT BACK, REAR
EXIT DUALS

MBRP
INC.
PERFORMANCE EXHAUST

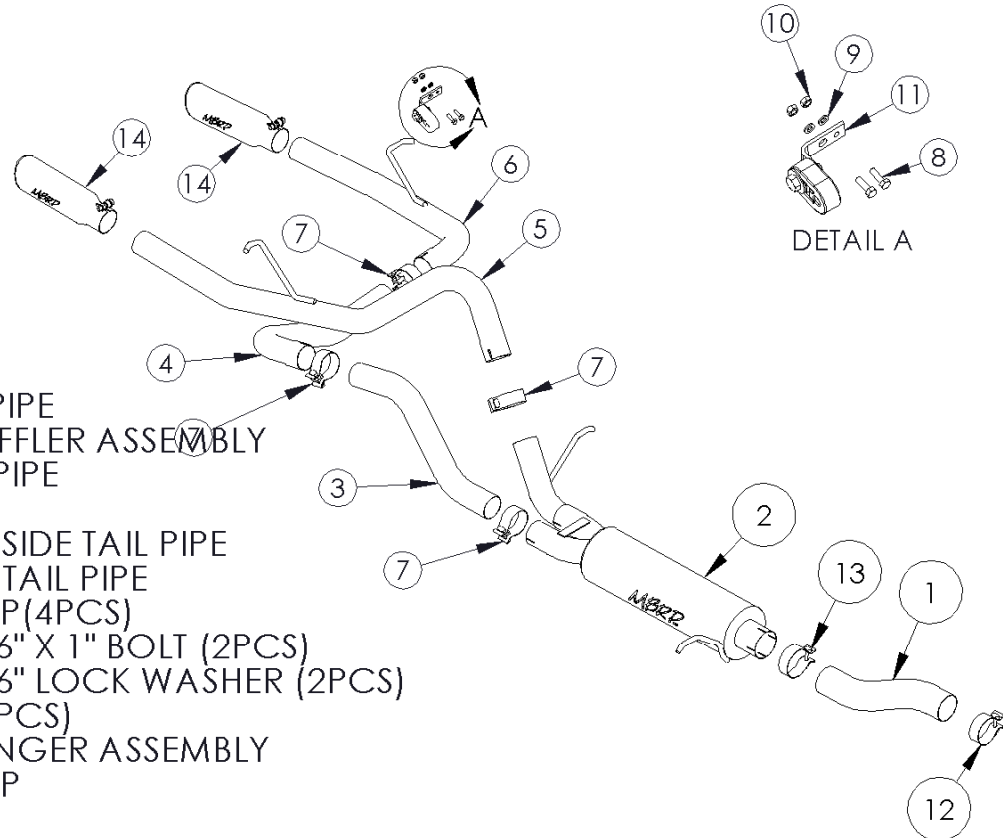

1. EXTENSION PIPE
2. <PARA >MUFFLER ASSEMBLY
3. OVER AXLE PIPE
4. CROSS PIPE
5. PASSENGER SIDE TAIL PIPE
6. DRIVER SIDE TAIL PIPE
7. 2 1/2" CLAMP (4PCS)
8. <PARA >5/16" X 1" BOLT (2PCS)
9. <PARA >5/16" LOCK WASHER (2PCS)
10. 5/16" NUT (2PCS)
11. <PARA >HANGER ASSEMBLY
12. 2 3/4" CLAMP
13. 3" CLAMP
14. EXHAUST TIP (2PCS)

NOTE: SADDLE CLAMPS USED IN ALUMINIZED SYSTEMS

NOTE: SPARE TIRE REMOVAL IS REQUIRED FOR THIS SYSTEM

PLEASE READ BEFORE STARTING INSTALLATION

While MBRP Inc. has made every effort to ensure that all components of this system are of superior quality and properly packaged, it is the installer's responsibility to ensure the following before removal of the factory exhaust:

- that ALL components shown above are present.
- that ALL mating components fit together.
- that there are no damaged components.
- that the system you have purchased is appropriate for your vehicle year, model and configuration.
- that the system will not interfere with any modifications previously installed or planned.
- that you have read and understand these instructions.

If you have any questions or are uncertain about any aspect of the installation of this system to your vehicle please contact your dealer before commencing installation.



Figure 1

Note: This System requires spare tire removal

Removal of Stock System:

1. Apply a penetrating lubricant liberally to all exhaust fasteners, hangers and rubber insulators.
2. Cut the exhaust in rear of the muffler so that the tail section can be removed from the vehicle.
3. Measure 4 1/2" in front of the cross member. The cross member is located just behind the Y-pipe. **Refer to Figure 2.**
4. Remove the hangers from the rubber insulators. Remove the exhaust from the vehicle. **Refer to Figure 3.**
5. Remove spare tire from the vehicle and relocate.



Figure 2



Figure 3

Installation of MBRP Inc. Performance Exhaust:

1. Install the Extension Pipe to the end of the Y-pipe using the 2 3/4" Clamp. **Refer to Figure 4.**



Figure 4



Figure 5

2. Slide a **3" Clamp** over the **Extension Pipe** and install the **Muffler** onto the **Extension Pipe**. Attach the **Muffler** to the existing rubber insulators. Refer to **Figure 5**.



Figure 6

3. Slide two **2 1/2" Clamps** over the outlets of the **Muffler**. Position the **Passenger Side Tail Pipe** and loosely attach it to the **Muffler**. Install the **Passenger Side Tail Pipe** hanger into the existing rubber insulator. Refer to **Figure 6**.



Figure 7

4. Loosely install the **Over Axle Pipe** to the **Muffler**. Refer to **Figure 7**.



Figure 8

5. Slide a **2 1/2" Clamp** over the **Over Axle Pipe** then loosely attach the **Cross Pipe** to the **Over Axle Pipe**. Refer to **Figure 8**.



Figure 9

6. Install the **Hanger Assembly** using the fasteners provided. Note some vehicles may require drilling to enlarge the one hole. Refer to **Figure 9**.



Figure 10

7. Slide a 2 ½” **Clamp** onto the **Cross Pipe** and then attach the **Driver Side Tail Pipe** hanger into the **Hanger Assembly** and to the **Cross Pipe**. Refer to **Figure 10**.



Figure 11

8. Install and adjust the **Exhaust Tips** to suit. Using a 17mm wrench tighten the lock bolt located on each **Exhaust Tip**. Refer to **Figure 11**.

9. Align the exhaust as required. Starting at the front of the exhaust, tighten all clamps and connections.

10. Check along the whole length of the exhaust system to ensure that there is adequate clearance around the spare tire, fuel and brake lines or any wiring. If any interference is detected relocate or adjust.



Congratulations! You are ready to begin experiencing the improved power, sound and driving experience of your MBRP Inc. performance exhaust system. We know you will enjoy your purchase.