

S5070

2011-2013 CHEVY SILVERADO/ GMC SIERRA, 6.2L, 1500 EXTENDED CAB, 6 1/2' BED/ CREW CAB, CAT BACK, SINGLE

MBRP
INC.
PERFORMANCE EXHAUST

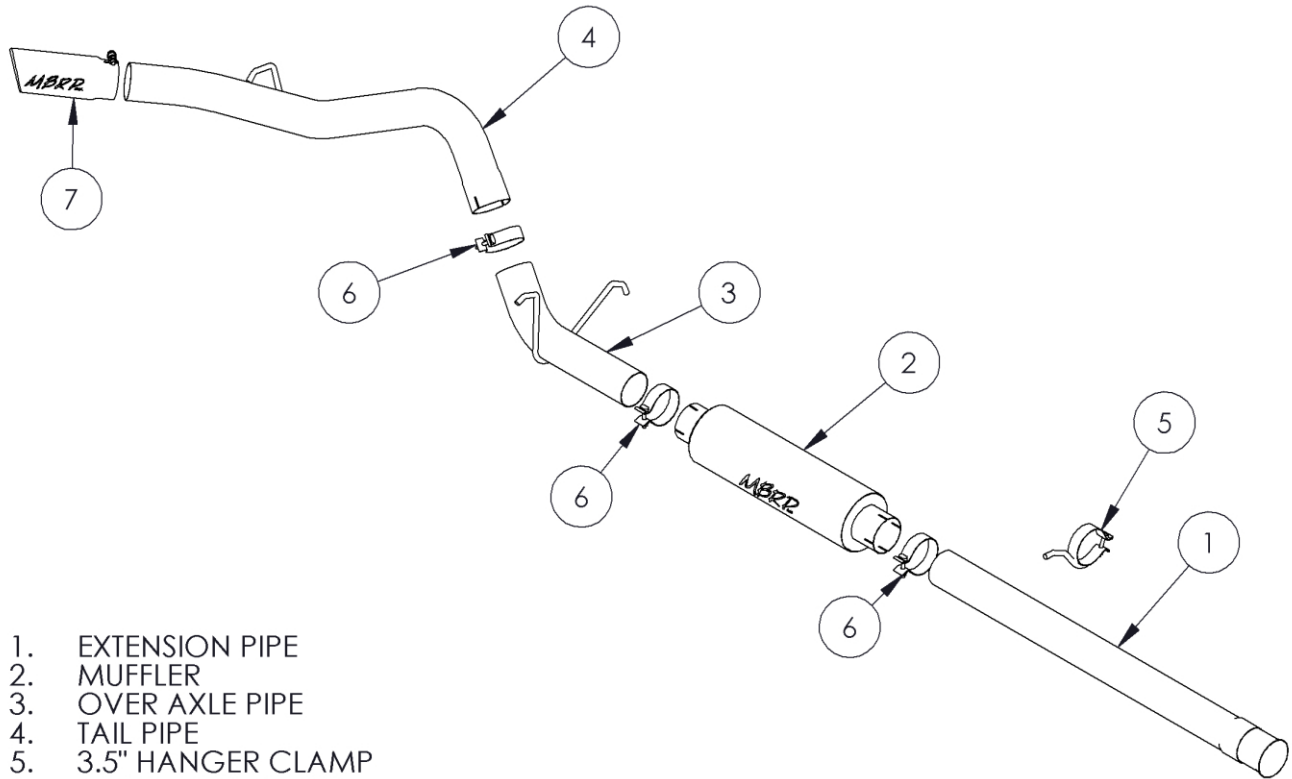

1. EXTENSION PIPE
2. MUFFLER
3. OVER AXLE PIPE
4. TAIL PIPE
5. 3.5" HANGER CLAMP
6. 3.5" CLAMP (3PCS)
7. EXHAUST TIP

NOTE : SADDLE CLAMPS ARE USED IN ALUMINIZED SYSTEMS

PLEASE READ BEFORE STARTING INSTALLATION

While MBRP Inc. has made every effort to ensure that all components of this system are of superior quality and properly packaged, it is the installer's responsibility to ensure the following before removal of the factory exhaust:

- that ALL components shown above are present.
- that ALL mating components fit together.
- that there are no damaged components.
- that the system you have purchased is appropriate for your vehicle year, model and configuration.
- that the system will not interfere with any modifications previously installed or planned.
- that you have read and understand these instructions.

If you have any questions or are uncertain about any aspect of the installation of this system to your vehicle please contact your dealer before commencing installation.

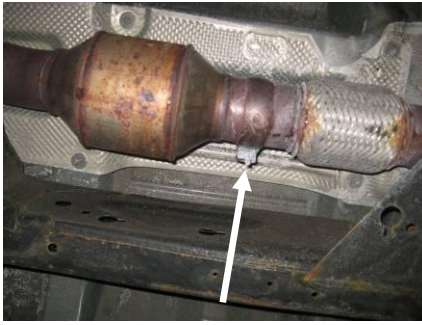

Figure 1

Removal of Stock System:

1. Apply a penetrating lubricant liberally to all exhaust fasteners, hangers and rubber insulators.

2. Remove the clamp after the catalytic converter and save the clamp for the installation. **Refer to Figure 1.**

3. The tail pipe will need to be cut to clear the rear axle. **Refer to Figure 2.**

4. Remove the hangers from the rubber insulators and remove the exhaust from the vehicle. **Refer to Figure 3.**



Figure 2



Figure 3

Installation of MBRP Inc. Performance Exhaust:

1. Loosely attach the **Extension Pipe** to the flange using the stock clamp. Slide the **3.5" Hanger Clamp** onto the rear of the **Extension Pipe** and into the existing rubber insulator. **Refer to Figure 4.**

2. Slide a **3.5" Clamp** onto the rear of the **Extension Pipe**. Install the **Muffler** onto the **Extension Pipe** and slide a **3.5" Clamp** onto the rear of the **Muffler**.



Figure 4



Figure 5

3. Feed the **Over Axle Pipe** into the **Muffler** and install hangers into the factory rubber insulators. **Refer to Figure 5.**

4. Slide a **3.5" Clamp** onto the rear of the **Over Axle Pipe**. Feed the **Tail Pipe** onto the **Over Axle Pipe**.

5. Install the **Tail Pipe** hanger into the factory rubber insulator located directly above the hanger. **Refer to Figure 6.**

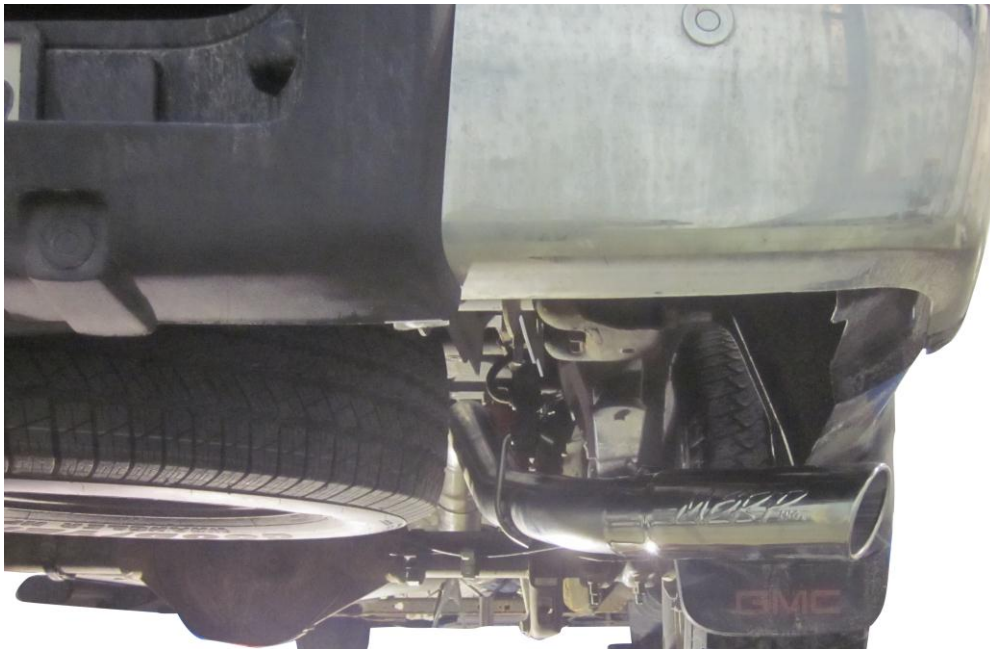

Figure 6

6. Loosely install and adjust the **Exhaust Tip** to suit. **Refer to Figure 6.**

7. Align the exhaust as required. Starting at the front of the exhaust, tighten all clamps and connections. Tighten the lock bolt located on the **Exhaust Tip**.

8. Check along the whole length of the exhaust system to ensure that there is adequate clearance around the spare tire, fuel and brake lines or any wiring. If any interference is detected relocate or adjust.



Congratulations! You are ready to begin experiencing the improved power, sound and driving excitement of your MBRP Inc. performance exhaust system. We know you will enjoy your purchase.