

S5056

'09-'13 CHEVY SILVERADO/GMC SIERRA
1500 SERIES, EXCLUDES EXTENDED CAB 8'
BED, 4.8L, 5.3L & 6.0L, CAT BACK, SIDE EXIT
DUALS

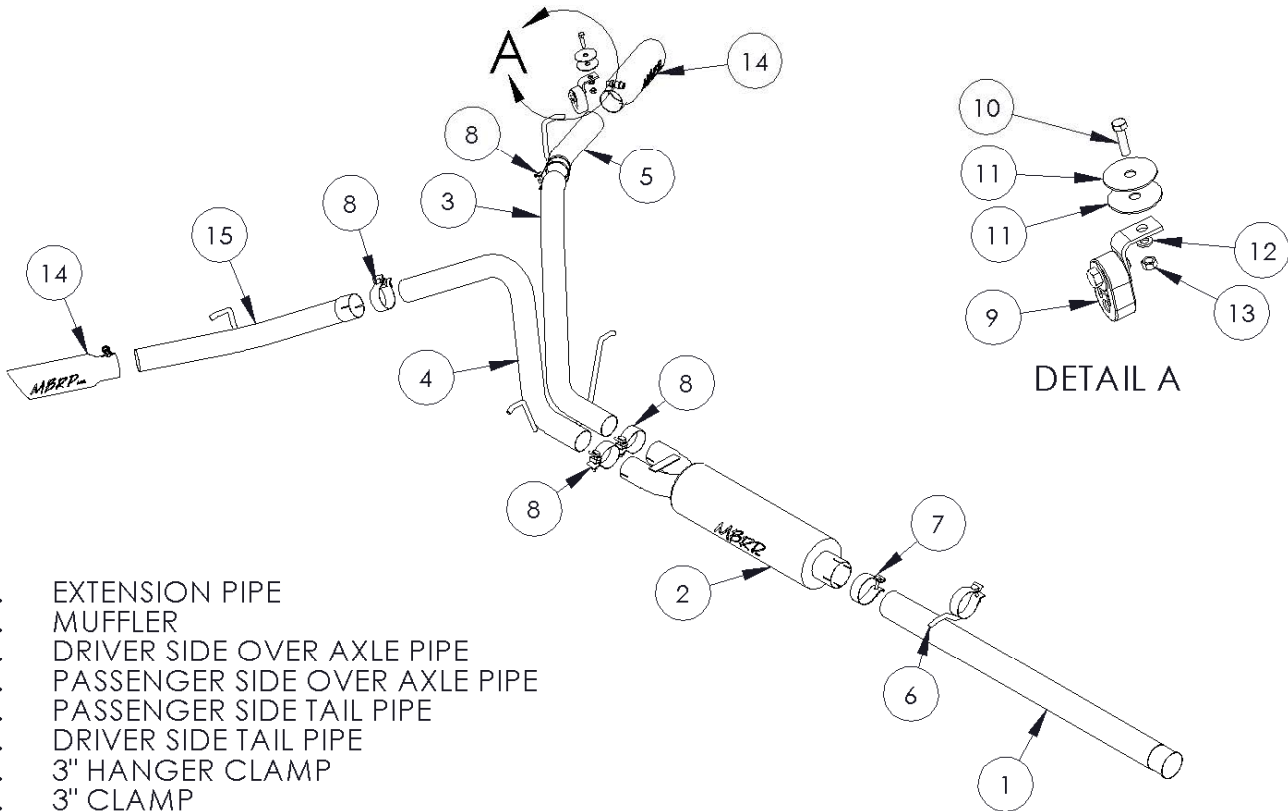

1. EXTENSION PIPE
2. MUFFLER
3. DRIVER SIDE OVER AXLE PIPE
4. PASSENGER SIDE OVER AXLE PIPE
5. PASSENGER SIDE TAIL PIPE
6. DRIVER SIDE TAIL PIPE
7. 3" HANGER CLAMP
8. 3" CLAMP
9. 2 1/2" CLAMP (4PCS)
10. HANGER ASSEMBLY
11. 3/8" X 1 1/2" HEX BOLT
12. 7/16" FENDER WASHER (2PCS)
13. 3/8" LOCK WASHER
14. 3/8" HEX NUT
15. EXHAUST TIP (2PCS)

NOTE SADDLE CLAMPS USED IN ALUMINIZED SYSTEMS

PLEASE READ BEFORE STARTING INSTALLATION

While MBRP Inc. has made every effort to ensure that all components of this system are of superior quality and properly packaged, it is the installer's responsibility to ensure the following before removal of the factory exhaust:

- that ALL components shown above are present.
- that ALL mating components fit together.
- that there are no damaged components.
- that the system you have purchased is appropriate for your vehicle year, model and configuration.
- that the system will not interfere with any modifications previously installed or planned.
- that you have read and understand these instructions.

If you have any questions or are uncertain about any aspect of the installation of this system to your vehicle please contact your dealer before commencing installation.

'09-'13 Chevy/GMC Silverado/Sierra 1500



Figure 1



Figure 2



Figure 3



Figure 4

Removal of Stock System

1. Apply a penetrating lubricant liberally to all exhaust fasteners, hangers and rubber insulators.
2. Remove the clamp after the catalytic converter and save the clamp for the installation. **Refer to Figure 1.**
3. The tail pipe can be cut to clear the rear axle. **Refer to Figure 2.**
4. Remove the hangers from the rubber insulators and remove the exhaust from the vehicle. **Refer to Figure 3.**

Installation of MBRP Inc. Performance Exhaust

1. Install the Extension Pipe to the existing flange using the clamp removed earlier. Leave the hardware loose enough for some adjustment. **Refer to Figure 4.** The **Extension Pipe** will not need cutting for the Crew Cab short bed or the Extended Cab long bed. Refer to **Figure 5** for cut lengths. (**Installation tip:** Temporarily hang the **Muffler** and the **Over Axle Tail Pipe** in place and measure to the back of the Catalytic Converter to verify the length required).

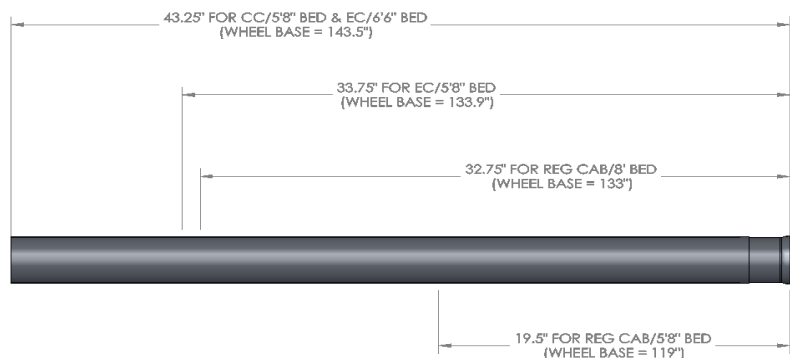

Figure 5



Figure 6

2. Slide the **3" Hanger Clamp** onto the rear of the **Extension Pipe** and attach to the existing rubber insulator. **Refer to Figure 6.** Note: an additional **3" Clamp** will be required on some models.



Figure 7

3. Install **Muffler** onto the **Extension Pipe** using the **3" Hanger Clamp**. **Refer to Figure 7.**



Figure 8

4. Slide a **2 1/2" Clamp** onto the **Passenger Side Over Axle Pipe** and slide onto the passenger side of the **Muffler**. Attach the hanger to the factory rubber insulator. **Refer to Figure 8.**



Figure 9

5. Slide a **2 1/2" Clamp** onto the **Driver Side Over Axle Pipe** and slide onto the driver side of the **Muffler**. Attach the hanger to the factory rubber insulator.

6. Slide the **Passenger Side Tail Pipe** hanger into the rearmost rubber insulator and reattach the frame. Slide a **2 1/2" Clamp** onto the **Driver Side Tail Pipe** then attach to the **Driver Side Over Axle Pipe**. **Refer to Figure 9.**



Figure 10

7. Slide a **2 1/2" Clamp** onto the **Driver Side Tail Pipe** then attach to the **Driver Side Over Axle Pipe**. Using fasteners provided attach the **Hanger Assembly** to the bottom of the frame. **Refer to Figure 10.**



Figure 11

8. Install and adjust the **Exhaust Tips** to suit. Using a 17mm wrench tighten the lock bolt located on the **Exhaust Tips**. Refer to **Figure 11**.

9. Align the exhaust as required. Starting at the front of the exhaust, tighten all clamps and connections.

10. Check along the whole length of the exhaust system to ensure that there is adequate clearance around the spare tire, fuel and brake lines or any wiring. If any interference is detected relocate or adjust.



Congratulations! You are ready to begin experiencing the improved power, sound and driving experience of your MBRP Inc. performance exhaust system. We know you will enjoy your purchase.