

S4704

2018 - UP KIA STINGER, 3.3L
RWD/AWD, 2.5" CAT-BACK,
DUAL REAR, NO TIPS - USES
FACTORY BEZEL

MBRP

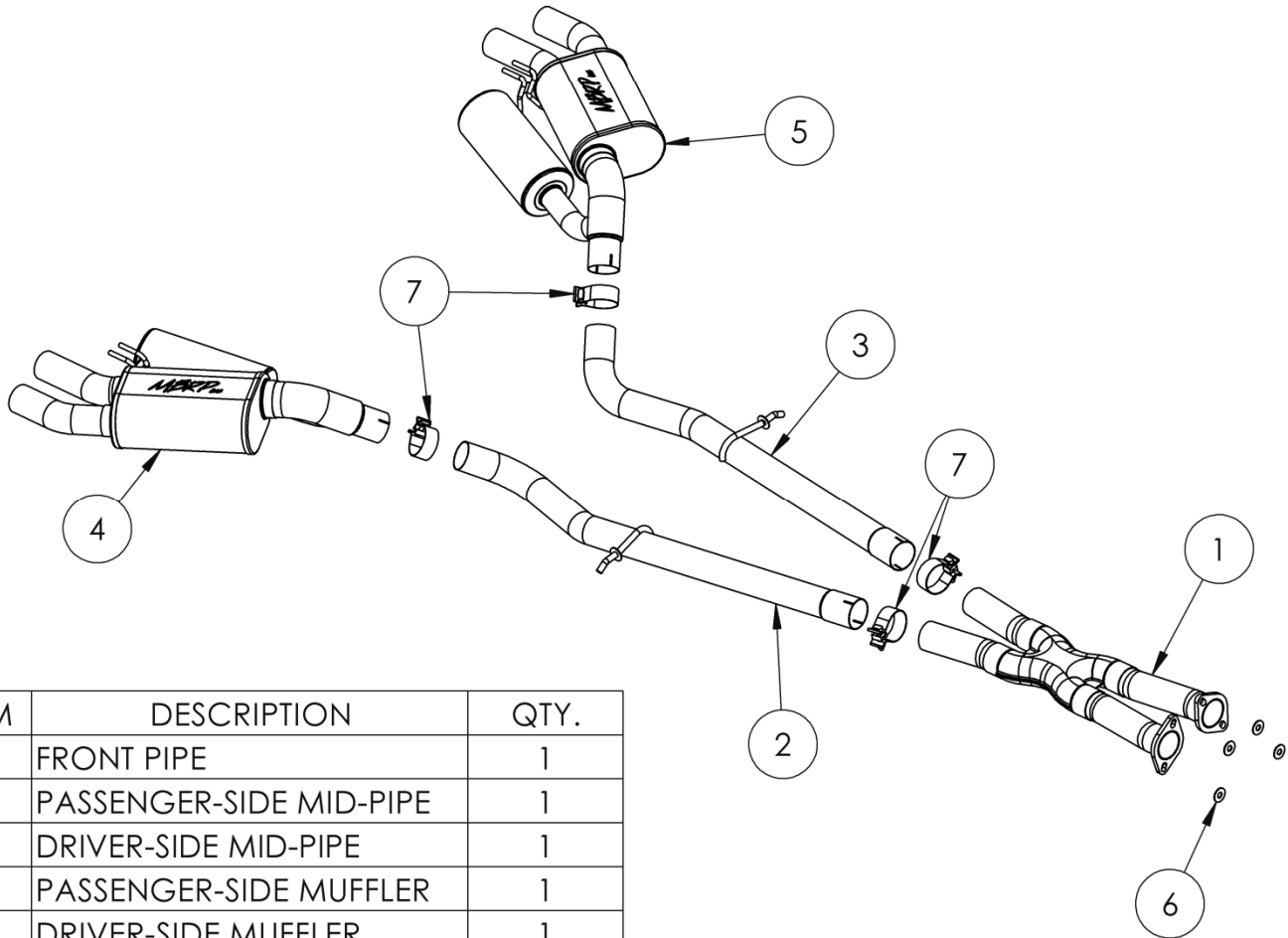

ITEM	DESCRIPTION	QTY.
1	FRONT PIPE	1
2	PASSENGER-SIDE MID-PIPE	1
3	DRIVER-SIDE MID-PIPE	1
4	PASSENGER-SIDE MUFFLER	1
5	DRIVER-SIDE MUFFLER	1
6	7/16" FLAT WASHER	4
7	2.5" CLAMP	4

PLEASE READ BEFORE STARTING INSTALLATION

While MBRP Inc. has made every effort to ensure that all components of this system are of superior quality and properly packaged, it is the installer's responsibility to ensure the following before removal of the factory exhaust:

- that ALL components shown above are present.
- that ALL mating components fit together.
- that there are no damaged components.
- that the system you have purchased is appropriate for your vehicle year, model and configuration.
- that the system will not interfere with any modifications previously installed or planned.
- that you have read and understand these instructions.

If you have any questions or are uncertain about any aspect of the installation of this system to your vehicle please contact your dealer before commencing installation.

MBRP



Figure 1



Figure 2



Figure 3



Figure 4



Figure 5

Removal of Stock System

1. Apply penetrating lubricant liberally to all exhaust fasteners, hangers and rubber insulators.
2. Remove the nuts from the rear muffler flanges and cross-brace. Remove the rear mufflers from the insulators and from the vehicle.
3. Remove the front pipe nuts after the catalytic converters and save the nuts for the installation. Remove the chassis cross-brace bolts.
Refer to Figure 1.
4. Remove the hangers from the rubber insulators and remove the front pipe from the vehicle. Ensure the factory gaskets remain on the catalytic converters for installation.

Installation of MBRP Performance Exhaust

1. Using the factory nuts removed in Step 2, and four **7/16" Flat Washers**, loosely attach the **Front Pipe** onto the catalytic converters. It is a tight fit but will squeeze between the cross-brace and the heat shield. Reinstall the chassis cross-brace bolts.
Refer to Figure 2.
2. Using a **2.5" Clamp**, loosely install the **Passenger-Side Mid-Pipe** onto the **Front Pipe** and into the factory rubber insulator. Repeat for the **Driver-Side Mid-Pipe**.
Refer to Figure 3.
3. Using a **2.5" Clamp**, loosely install the **Driver-Side Muffler**. Direct the exhaust outlets into the factory bezel, then install the inlet over the **Mid-Pipe**, then the hangers into the factory rubber insulator. Repeat for the **Passenger-Side Muffler**.
Refer to Figure 4.
4. Carefully align all parts of the system to achieve the best possible fit with the **Muffler Outlets** centered in the exhaust bezels. Take time now and check alignment each time you tighten a joint.
Refer to Figure 5.
5. Tighten all hardware and clamps, starting at the front and working rearward to secure the system. Check along the full length of the exhaust system to ensure there is adequate clearance for fuel lines, vent lines, brake lines, frame, bodywork, suspension and any wiring, etc. If there is any interference detected, relocate or adjust to provide adequate clearance.

Congratulations! You are ready to begin experiencing the improved power, sound and driving experience of your **MBRP** Performance Exhaust. We know you will enjoy your purchase!