

FS9-CA459/FAL-CA459

4" DOWN PIPE

2011-2014 6.7L FORD POWERSTROKE ,
2015 CAB AND CHASSIS ONLY

MBRP
INC.
PERFORMANCE EXHAUST

CARB EO# D-763-1

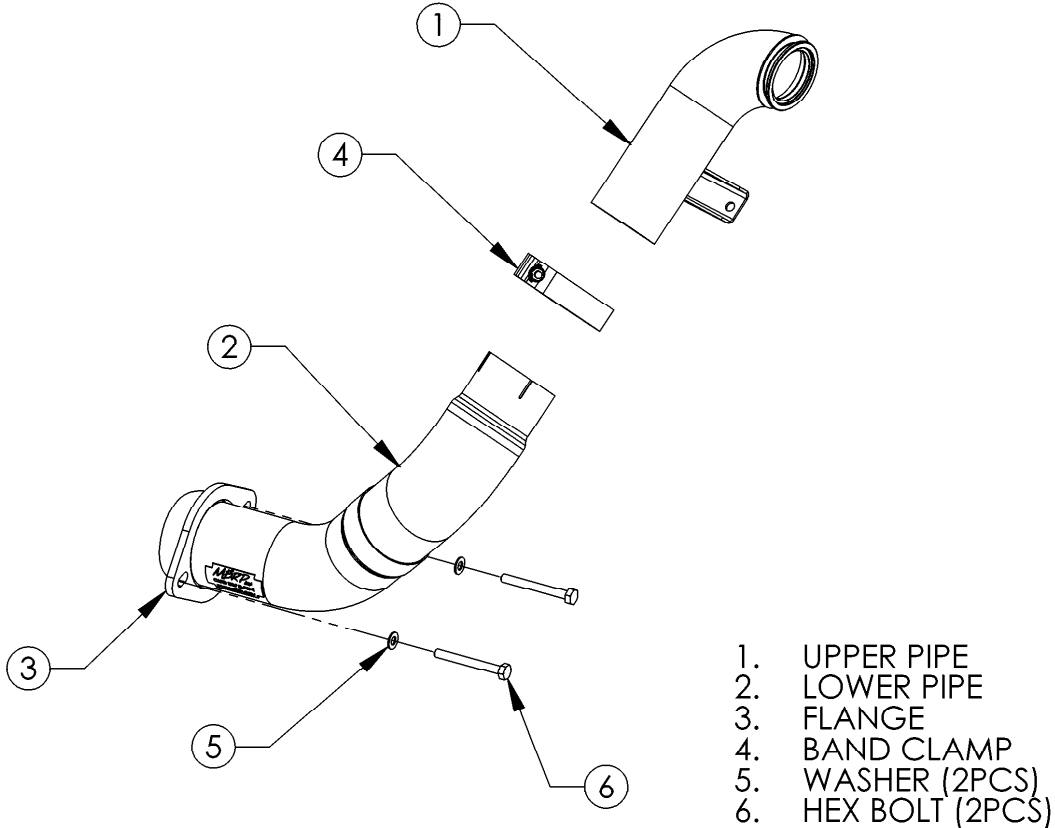

PLEASE READ BEFORE STARTING INSTALLATION

While MBRP Inc. has made every effort to ensure that all components of this system are of superior quality and properly packaged, it is the installer's responsibility to ensure the following before removal of the factory exhaust:

- that ALL components shown above are present.
- that ALL mating components fit together.
- that there are no damaged components.
- that the system you have purchased is appropriate for your vehicle year, model and configuration.
- that the system will not interfere with any modifications previously installed or planned.
- that you have read and understand these instructions.

If you have any questions or are uncertain about any aspect of the installation of this system to your vehicle please contact your dealer before commencing installation.

**2011-2014, 2015 Cab and Chassis Only,
Ford Super Duty 6.7L Powerstroke Diesel**

Removal of Stock Down Pipe:



Figure 1

1. Remove the front passenger-side wheel and then remove the wheel liner to access the upper half of the stock down pipe.

2. Remove the 2 OEM bolts from the ball flange at the outlet of the down pipe. Use a pry-bar to shift the particulate filter rearward to allow the OEM down pipe to drop down a few inches. **Refer to Figure 1.**

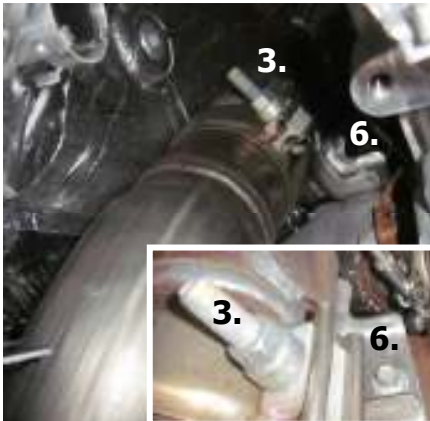

Figure 2

3. Loosen the clamp connecting the upper and lower halves of the stock down pipe. **Refer to Figure 2.**

4. Use a pry-bar to shift the particulate filter rearward to allow the bottom end of the OEM down pipe to drop down and be removed.

5. Loosen the OEM V-band Clamp at the turbo outlet. Once loose, the clamp bolt can be released from the clamp.

6. Remove the bolt securing the bracket at the bottom end of the upper down pipe section. **Refer to Figure 2.** Do not discard the bolt.

7. The upper half of the down pipe can now be removed. If it is stuck in place it may be necessary to use a pry bar and/or an air hammer to loosen it.

Installation of MBRP Inc. Down Pipe:



Figure 3

1. Install the **Upper Pipe** onto the turbo, reusing the stock V-band clamp. It is helpful to expand the v-band clamp over the outer edge of the **Upper Pipe** flange in order to get it properly in place over the turbo outlet flange and the pipe flange. Once the **Upper Pipe** is in position, loosely install the OEM V-band Clamp, orientating it such that the bolt can be easily tightened.

2. Reinstall the flange bolt through the bracket on the **Upper Pipe**, then fully tighten the V-band clamp and the flange bolt to secure the **Upper Pipe**. **Refer to Figure 3.**



Figure 4

3. Install the **Lower Pipe** by first sliding the supplied **Band Clamp** over the pipe and then sliding it onto the **Upper Pipe**. Do not tighten yet. **Refer to Figure 4.**

4. Using the supplied **Hex Bolts**, loosely secure the 2-bolt down pipe flange to the OEM flange.

5. Ensure that there is enough clearance between the MBRP down pipe assembly and the firewall, transmission cooler lines, and frame. Adjust if necessary. Once clearances have been checked, tighten the remaining clamps and flanges.

6. Replace the wheel liner and the front passenger-side wheel.