

# S5332

2001-2004 Toyota Tacoma  
Cat Back Single Turndown  
EC & CC 4X4

**MBRP**  
INC.  
PERFORMANCE EXHAUST

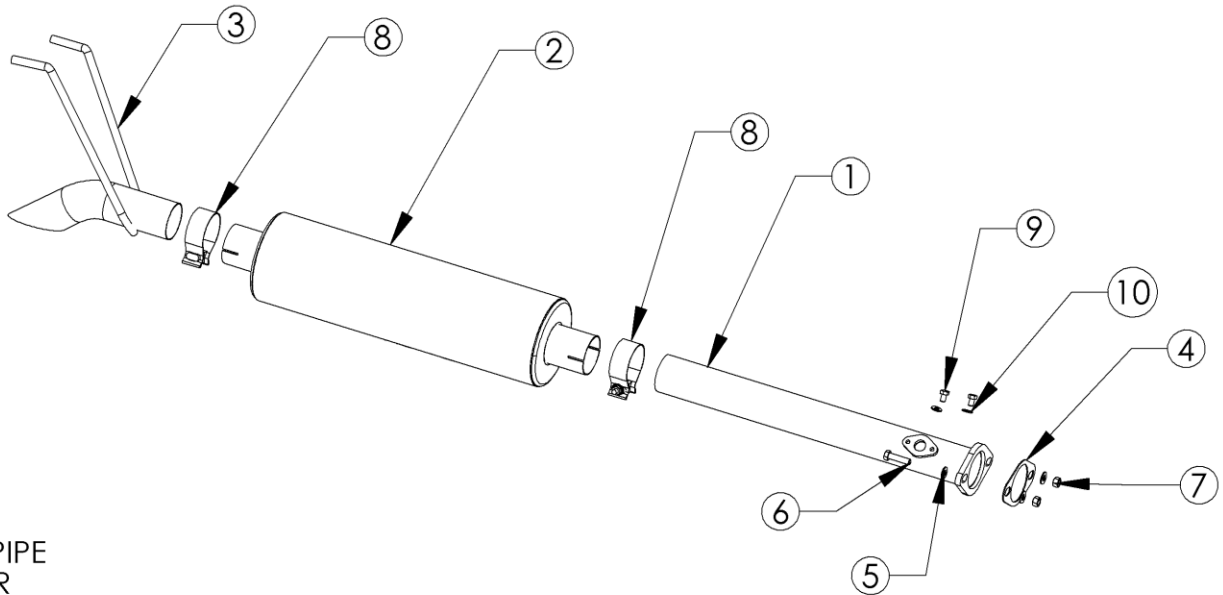

1. FRONT PIPE
2. MUFFLER
3. TURN DOWN PIPE
4. FLANGE GASKET
5. 3/8" WASHER (4PCS)
6. 3/8" BOLT (2PCS)
7. 3/8" HEX NUT (2PCS)
8. 2.5 CLAMP (2PCS)
9. 5/16" HEX BOLT (2PCS)
10. 5/16" FLAT WASHER (2PCS)

NOTE: SADDLE CLAMPS USED FOR ALUMINIZED SYSTEM

## PLEASE READ BEFORE STARTING INSTALLATION

**While MBRP Inc. has made every effort to ensure that all components of this system are of superior quality and properly packaged, it is the installer's responsibility to ensure the following before removal of the factory exhaust:**

- that ALL components shown above are present.
- that ALL mating components fit together.
- that there are no damaged components.
- that the system you have purchased is appropriate for your vehicle year, model and configuration.
- that the system will not interfere with any modifications previously installed or planned.
- that you have read and understand these instructions.

If you have any questions or are uncertain about any aspect of the installation of this system to your vehicle please contact your dealer before commencing installation.



**Figure 1**

### Removal of Stock System:

1. Apply a penetrating lubricant liberally to all exhaust fasteners, hangers and rubber insulators.
2. Loosen the nuts that fasten the rear Oxygen sensor and remove the sensor from the stock exhaust system. Keep the existing gasket for the oxygen sensor as it will be needed for install. **Refer to Figure 1.**
3. Loosen the bolts on the flange in front of the Oxygen sensor. **Refer to Figure 1.**
4. Remove the hangers from the rubber insulators and remove the exhaust from the vehicle. If a hoist or hydraulic lift is not being used the tail pipe may need to be cut to clear the rear axle.



**Figure 2**

### Installation of MBRP Inc. Performance Exhaust:

1. Install the **Front Pipe** to the existing flange using the fasteners and gasket provided. **Refer to Figure 2.**
2. Install the Oxygen sensor in to the flange on the **Front Pipe** and fasten with the hardware provided. Re-use the existing gasket. Heat resistant silicon may be required depending on condition of existing gasket. **Refer to Figure 3**
3. Place **2.5" Clamp** on to the front of the **Muffler** and install the muffler on to the **Front Pipe**. **Refer to Figure 4.**



**Figure 3**



**Figure 4**



**Figure 5**

4. Loosely install a 2.5" **Clamp** on the exit of the muffler and insert the **Turn-Down Tip** into the muffler. Slide both hangers into the stock rubber insulator. **Refer to Figure 5.**

**Congratulations!** You are ready to begin experiencing the improved power, sound and driving excitement of your MBRP Inc. performance exhaust system. We know you will enjoy your purchase.