

AD1710

2011 CONVERTIBLE CAMARO REINFORCEMENT BRACE SPACER KIT

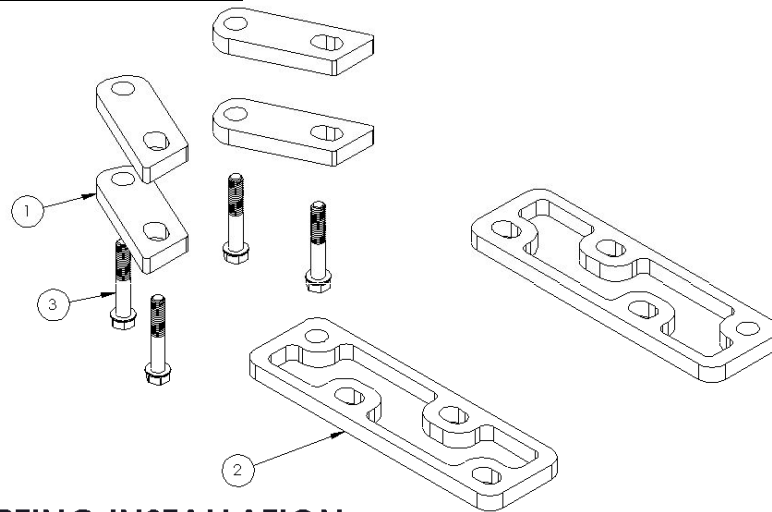

1. REAR SPACER (4PCS)
2. FRONT SPACER (2PCS)
3. M10 X 60mm HEX BOLT (4PCS)

PLEASE READ BEFORE STARTING INSTALLATION

MBRP Inc. has made every effort to ensure that these components are of superior quality and properly packaged. It is the installer's responsibility to ensure that the components are complete, including any additional hardware and that it is undamaged. This should be done prior to the removal of factory components. Finally, check that this component properly matches the make and model of the vehicle and will not interfere with previous or planned modifications.

For use with MBRP 3" Exhaust Systems

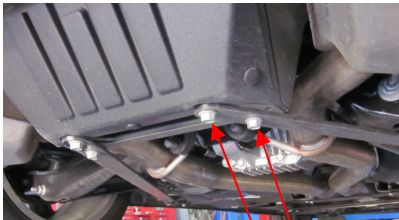

Figure 1



Figure 2



Figure 3



Figure 4

1. Remove the rear reinforcement braces shown in figure one. (15 mm socket)
2. Remove the front reinforcing brace and retain the hardware for reinstallation. Note: these parts need to be temporarily removed when removing the stock exhaust.
3. With the new exhaust installed, reinstall the front reinforcing brace. Reusing the stock hardware place the **Front Spacers** between the brace and the vehicle body.
4. Install the reinforcing braces by reusing the stock hardware except where the **Rear Spacers** mount. Install the rear reinforcing braces placing the **Rear Spacers** between the brace and the vehicle body. Secure the **Rear Spacers** using the **M10 x 60mm Hex Bolts** provided.

