



Mastercool®
"World Class Quality"

OPERATING INSTRUCTIONS

Two Stage Deep Vacuum Pump

MODEL# 90063-2V-110-B, 90063-2V-220-B, 90066-2V-110-B,
90066-2V-220-B, 90068-2V-110-B, 90068-2V-220-B,
90612-2V-110-B, 90612-2V-220-B



In order to make the best use of your investment, familiarize yourself with the new features and operating instructions before starting pump. Routine care and maintenance of your vacuum pump will give you years of reliable service.

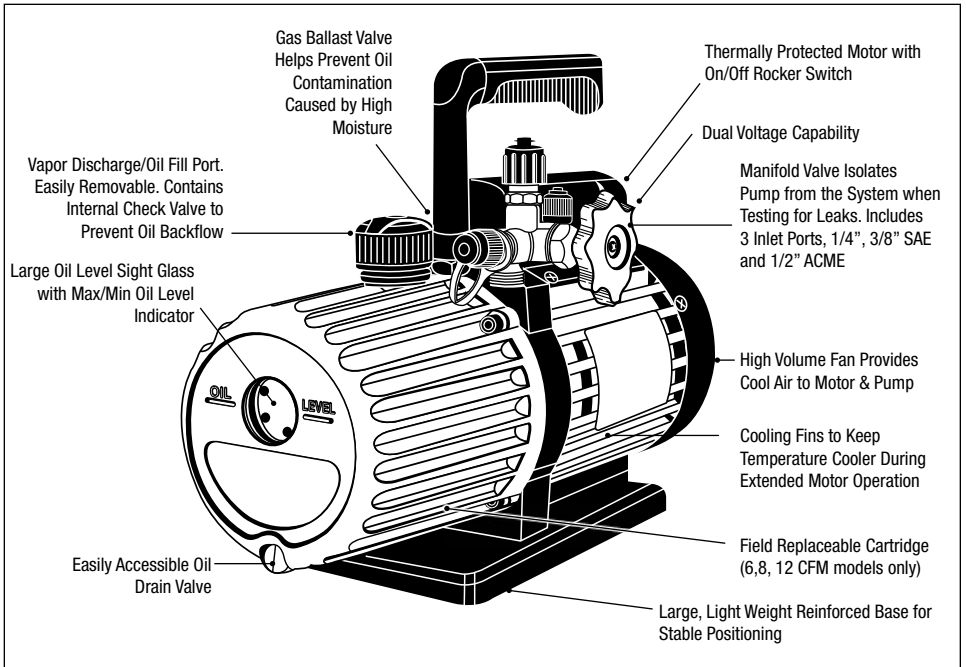

FEATURES

- A check valve is built into the suction line to prevent oil backup in case of power loss.
- A built-in device eliminates oil mist and an oil-gas separator at the air exhaust outlet and prevents oil contamination in the air exhaust.
- Specially designed for low temperature and low voltage conditions to guarantee normal starting in winter; $\geq 41^{\circ}\text{F}$ ($\geq 5^{\circ}\text{C}$) temperature and $\pm 10\%$ rated voltage.
- Pump runs with extremely high ultimate vacuum and low noise.

EACH VACUUM PUMP HAS BEEN FACTORY TESTED FOR CFM AND MICRON PERFORMANCE.



DO NOT ATTEMPT TO OPERATE WITHOUT USING OIL!!!

Use oil specifically refined for Deep Vacuum Pumps. Use of oil not refined for Deep Vacuum Pumps and/or operating with contaminated oil will void warranty.



WARNING:

1. Do not evacuate combustible, explosive or poisonous gases.
2. Do not evacuate gases that corrode metal or react chemically with pump oil.
3. The temperature of evacuated gas shall not exceed 176°F (80°C) and ambient temperature shall be $41 - 140^{\circ}\text{F}$ ($5 - 60^{\circ}\text{C}$).
4. Do not operate without oil.



WARNING!



WEAR SAFETY GLASSES

- Do not touch the machine's hot surface during operation.
- Do not block air outlet.

CAUTION:

To reduce the danger of electric shock, keep the pump indoors and do not expose to rain.

DANGER:

- With a grounding socket the operating voltage is rated $\pm 10\%$; Receptacle shall be well grounded, or else electric shock may be caused. Should power cord or plug require repair or replacement, do not connect grounded wire to any flat adapter connector. If its surface is green, with or without yellow stripe, the insulation wire is grounding wire. If you cannot fully understand grounding instructions and have doubt whether correct grounding is made, check with a professional electrician or service man. Do not change the structure of attached adapter connector.
- When pulling out power plug, make sure to pull the plug rather than the wire.
- Do not place heavy matter on power wire or let power wire be squeezed.
- Do not use broken plug or socket.
- Do not pull out power plug with wet hand.
- Do not pull out, insert power plug or turn on power switch where flammable gases may be present.

1. OIL FILL

This vacuum pump has been tested at the factory and shipped with only trace amounts of oil.

OIL MUST BE ADDED BEFORE OPERATING! Failure to add oil will damage cartridge and void warranty!

- Make sure the oil drain valve located below the front casing is closed before attempting to add oil.
- Remove the large oil fill plug from the top of pump and insert the oil bottle into the fill port.
- Slowly add oil until oil level rises to the top of the Oil Level Line. Do not overfill with oil!
- Replace oil fill port.

OIL CAPACITY:

3 CFM 8.5 oz. (250 ml)	6 CFM 15 oz. (440 ml)	8 CFM 19 oz. (570 ml)	12 CFM 18 oz. (536 ml)
---------------------------	--------------------------	--------------------------	---------------------------

2. CHECKING OIL LEVEL

- Open the gas ballast valve (small brass fitting located next to the handle) one turn.
- Start pump and run with intake port capped for about two minutes. Observe the oil level with the pump running. The oil level in the sight glass should be even with the level line.
- If the level is low, open the intake port and run pump for 15 seconds, stop pump and observe oil level again. Add a small amount of oil as needed.

3. GAS BALLAST VALVE

The gas ballast valve must be opened 1/4 turn for the first part of the evacuation procedure. This will help to eliminate moisture and extend the life of the vacuum pump. After about two minutes close the valve and continue the evacuation procedure to reach ultimate vacuum. Failure to close the valve completely during the final evacuation will result in high vacuum reading.

During the first stages of evacuation, vapors are highly concentrated. Unfortunately, some vapors will condense into a liquid and mix with the oil, thus reducing the oil's ability to produce a deep vacuum. The **GAS BALLAST VALVE** emits a controlled amount of dry air into the pump during compression to minimize this effect and keep oil relatively clean during the first part of the evacuation.

Periodically remove the Gas Ballast Valve Needle and clean or replace the O-ring. Clean mating surfaces and lightly coat with vacuum pump oil before securely re-tightening.

4. CHANGING OIL

In order to reach the deep vacuum required, your vacuum pump needs clean, moisture-free oil during evacuation. Dirty oil becomes a mixture of corrosive acids and water that effects the pump's ability to pull a deep vacuum. Left sitting in the pump, this sludge will rust and erode internal surfaces shortening the pump's life.

Care should be taken to avoid contact of oil with skin or eyes. OIL MAY BE HOT! Used oil should be properly disposed of in a leak-proof corrosive-resistant container according to local regulations.

- After every evacuation, while the pump is warm and oil is thin, take a small sample of oil from the drain port.
- If the oil is contaminated, drain the oil by placing the pump on a level surface and opening the oil drain valve. Catch the waste oil in a container and properly dispose of it.
- If the pump has been sitting for more than one month, the oil is considered contaminated regardless of appearance and should be changed as outlined above.
- To add oil, close drain, remove the oil fill cap and fill to the Oil Level Line with fresh oil.

5. INTAKE CONNECTIONS

Replace all caps and finger-tighten. Do not use caps with damaged or missing O-rings and always store vacuum pump with capped ports to prevent dirt and moisture contamination.

6. PUMP MOTOR

The PUMP and OIL must be above 30°F (1°C). The line voltage must be equal to the rating on the motor nameplate $\pm 10\%$. Normal operating temperature is approximately 160°F (71°C), which is HOT to the touch! Line voltage and ambient temperature will affect the normal operating temperature. Your vacuum pump is designed for continuous duty and will run for extended periods without overheating. The motor has an automatic resetting overload protection feature. If the motor will not restart the pump after shut-off, it may have opened the thermal protection. Disconnect the pump from the system, wait about 15 minutes for the motor to cool down and then try again.



Mastercool[®] Inc.
"World Class Quality"

**12 CFM, TWO STAGE
 VACUUM PUMP**

**REPAIRABLE PARTS BREAKDOWN
 (90612-2V-110-B)**

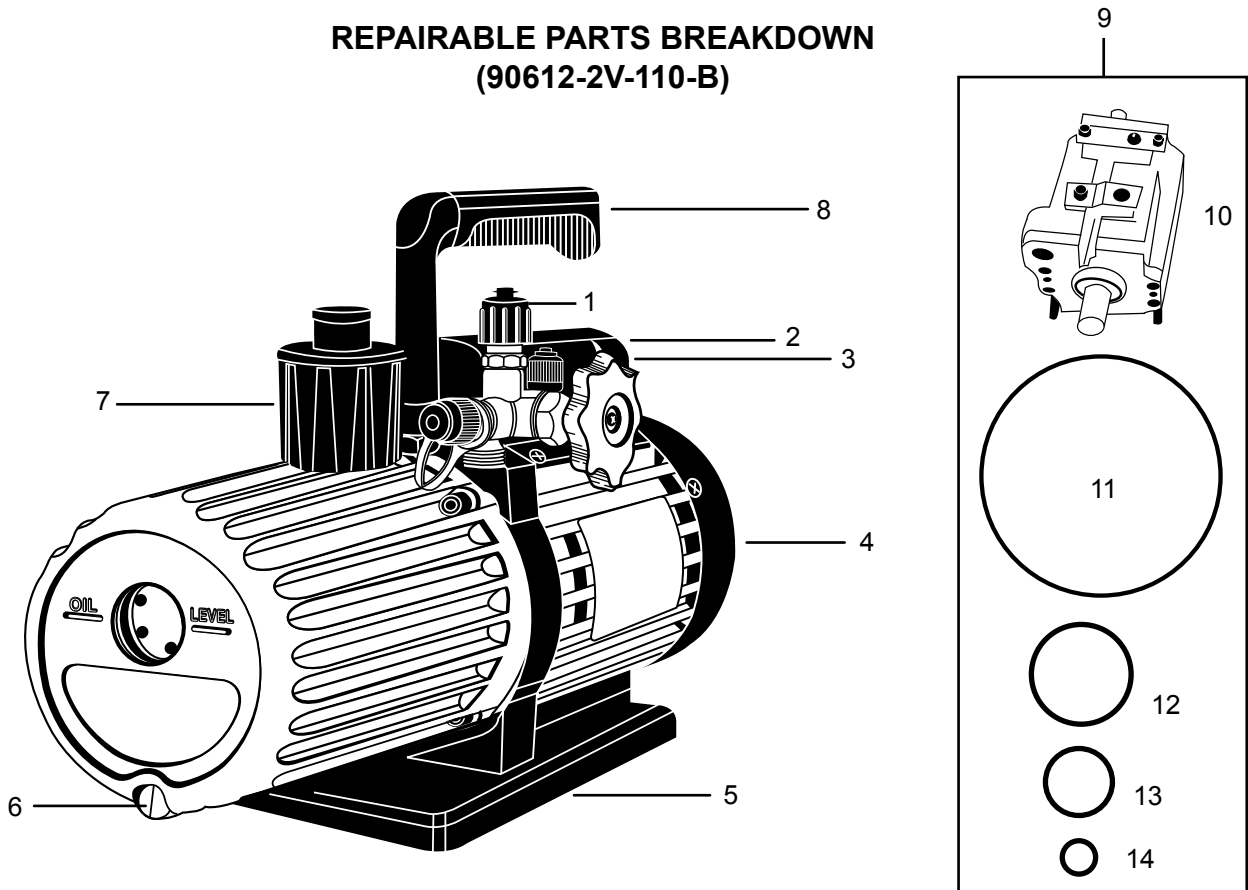

REF. #	DESCRIPTION	PART #
1.	T-FITTING	90056-18-R
2.	110V POWER CORD 220V POWER CORD	6535-110 6535-220
3.	ON/OFF SWITCH	90066-B-SW
4.	FAN COVER	90068-B-FC
5.	BASE PLATE	90068-B-BP
6.	OIL DRAIN FITTING WITH O-RINGS	90062-B-28
7.	EXHAUST FITTING	90068-10-B
8.	HANDLE	90612-B-H
9.	CARTRIDGE KIT	90112-B
10.	CARTRIDGE	90112B-03
11.	SHAFT SEAL	90068B-06
12.	PUMP COVER GASKET	90068B-13
13.	O-RING ON HOUSING	90066B-22
14.	SMALL O-RING ON HOUSING	90066B-23