

R134a Visual Inspection Sight Glass / R1234yf Visual Inspection Sight Glass

OPERATING INSTRUCTIONS



WARNING

- WEAR GOGGLES!!
- AVOID CONTACT WITH REFRIGERANT

PREPARING THE SIGHT GLASS

When Using Vacuum from a Recycling Machine

1. Connect both the red and the blue hoses supplied to the corresponding end of the sight glass.
2. Connect both the red and blue coupler to the corresponding end of the hose. Close each coupler by turning the knob counterclockwise (manual couplers only.) Connect the blue low side hose and coupler from your RRR machine to the low side fitting on the blue side of the sight glass.
3. Open both ball valves on each side of the sight glass.
4. Run a vacuum for 3 minutes from the control panel on your RRR machine. This will remove any atmosphere from the sight glass to allow for an accurate test.
5. Disconnect the low side RRR machine coupler from the sight glass when vacuum run time is completed.
6. Go to using the sight glass section.

When Using Vacuum from a Vacuum Pump

1. Close both ball valves. Connect the red hose supplied to the red side of the sight glass. Attach the high side coupler to the hose and close the coupler by turning the knob counterclockwise (manual couplers only.)
2. Connect the low side coupler to the blue hose and close the coupler by turning the knob counterclockwise (manual couplers only.)
3. Connect the low side coupler to the service port on the sight glass. Open the coupler by turning the knob clockwise (manual couplers only.)
4. Connect the other end of the blue hose to your vacuum pump.
5. Open the red high side ball valve, leave the blue low side ball valve closed.
6. Run your vacuum pump for 3 minutes. This will remove any atmosphere from the sight glass to allow for an accurate test.
7. Disconnect the blue hose from the vacuum pump when vacuum time is completed. Close the low side coupler by turning the knob counterclockwise (manual couplers only.) Disconnect the blue coupler from the sight

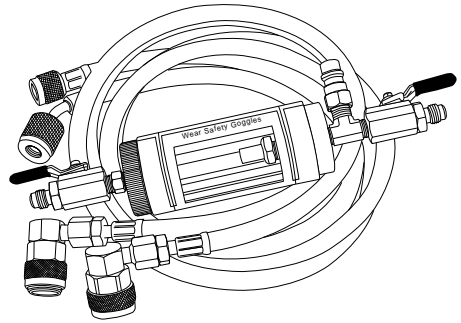

R134a Visual Inspection Sight Glass with R134a Quick Couplers

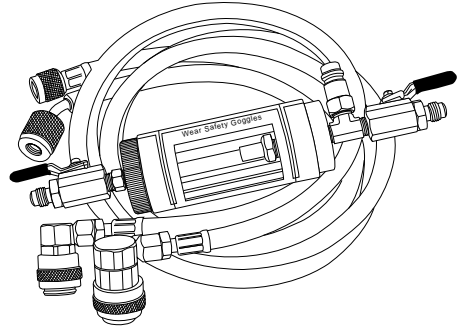

R1234yf Visual Inspection Sight Glass with R1234yf Quick Couplers

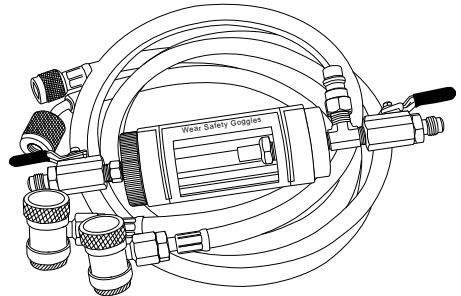

R134a Visual Inspection Sight Glass with R134a Manual Couplers

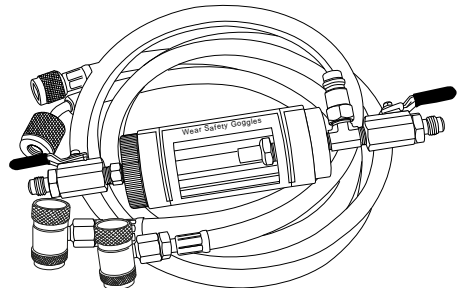

R1234yf Visual Inspection Sight Glass with R1234yf Couplers with Extended Disconnect Sleeve

glass. The fittings on the blue hose and coupler both have auto shutoff's which will maintain the vacuum created in the sight glass and hoses.

8. Connect the blue hose to the blue side of the sight glass.

USING THE SIGHT GLASS

1. Close both ball valves on the sight glass.
2. Connect the red coupler to the high side of the AC system. Open the coupler by turning the knob clockwise (manual couplers only.)
3. Connect the blue coupler to the low side of the AC system. Open the coupler by turning the knob clockwise (manual couplers only.)
4. Start the vehicle and turn the AC system on.
5. Hold the sight glass in a vertical position with the red hose down.
6. SLOWLY open the red side ball valve.
7. When the sight glass is $\frac{1}{4}$ full of liquid refrigerant, close the red side ball valve (be sure the blue side ball valve is still closed as well).
8. Allow the refrigerant to stabilize.
9. Check the color of the refrigerant using the chart below. Check for any debris in the refrigerant.

CLEARING THE SIGHT GLASS OF REFRIGERANT

1. To put the refrigerant back into the AC system, first turn off the AC system and vehicle.
2. Close the high side coupler by turning the knob counterclockwise (manual couplers only.) Remove the red coupler from the high side of the vehicle.
3. Turn on the vehicle and the AC system.
4. Open the red high side ball valve on the sight glass.
5. SLOWLY OPEN THE BLUE LOW SIDE BALL VALVE ON THE SIGHT GLASS.
6. Wait for 1 minute after the liquid refrigerant is removed from the sight glass. This allows any refrigerant in the blue hose to enter the AC system.
7. Close the low side coupler by turning the knob counterclockwise (manual couplers only.) Remove the blue coupler from the low side.
8. Turn off the AC system and the vehicle.

POSSIBLE CONTAMINANTS THAT CAN BE SEEN IN THE INSPECTION GLASS INCLUDE:

CARBONIZED OIL PARTICLES	When oil is exposed to high temperatures
RUBBER PARTICLES	Aggressive acids penetrating rubber parts
MOISTURE	Leaks, incorrect or insufficient vacuum or wrong/inferior quality additives
METAL SILVER/CHIPS	Compressor seizure or metal parts abrasion
AGGRESSIVE ACIDS	Chemical reaction between moisture and refrigerant/oil or incorrect oil mixtures
VARIOUS PARTICLES	Soiled compounds created from using poor quality or incorrect additives such as leak stop agents, UV dye or oil mixture composites

UNACCEPTABLE CONDITIONS

These conditions when viewed in the inspection glass are an indication of serious system/component issues



DARK GREEN
Excessive UV dye in the system



RUBBER/PLASTIC COMPOUNDS
Aged seals, strong additives reacting with seals and hoses, receiver dryer failure or too much dryer wear



RED/ORANGE
Excessive red leak tracing dye in the system

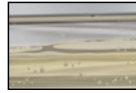

BUBBLE/PEARLS
Moisture in the system, contamination caused by insufficient quality additives, incorrect vacuum pulled during previous services



LIGHT BROWN
System or compressor subjected to overheating



GEL-LIKE, CRYSTALLIZED TEXTURE
Insufficient quality leak stop agents reacting with refrigerant/oil or UV dye, no/incorrect vacuum pulled before leak stop applications



DARK BROWN OR BLACK
System or compressor subjected to excessive overheating



CREAM/UNCLEAR TEXTURE
Aggressive flushing agent residues reacting with aluminum and teflon coating on the compressor's parts, incorrect flushing and vacuum pulled after flushing

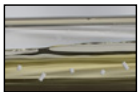

METAL CHIPS/PARTICLES
Compressor seizure caused by oil starvation or incorrect lubrication



IMBALANCED LIQUIDS MIXTURE
Application of universal/incorrect oils, unbalanced, non-homogeneous mixture of various oils

ACCEPTABLE CONDITIONS

These conditions when viewed in the inspection glass are an indication that no issues are present

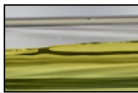

ACCEPTABLE CONDITION
Pure mix of refrigerant and lubricant

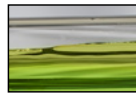

ACCEPTABLE CONDITION
Appropriate mix of refrigerant, lubricant and UV dye

PARTS LIST

Item #	Part #	Description
1.	53375	Refrigerant Oil Visual Inspection Sight Glass
2.	82274	Low Side, 1/4" (7/16"-20) x 13 mm Retrofit Adapter
3.	53376-601	60" Blue R134a Charging Hose
4.	53376-603	60" Red R134a Charging Hose
5.	66234	R134a High Side Quick Coupler
6.	66334	R134a Low Side Quick Coupler
7.	84274	1/4 fl-f x 17 mm-m R1234yf Adapter with Valve Core
8.	53376-601YF	60" Blue R1234yf Charging Hose
9.	53376-603YF	60" Red R1234yf Charging Hose
10.	67434	R1234yf High Side Quick Coupler
11.	67534	R1234yf Low Side Quick Coupler
12.	82834	R134a High Side Manual Coupler
13.	82934	R134a Low Side Manual Coupler
14.	83834	R1234yf High Side Manual Coupler with Extended Disconnect Sleeve
15.	83934	R1234yf Low Side Manual Coupler with Extended Disconnect Sleeve

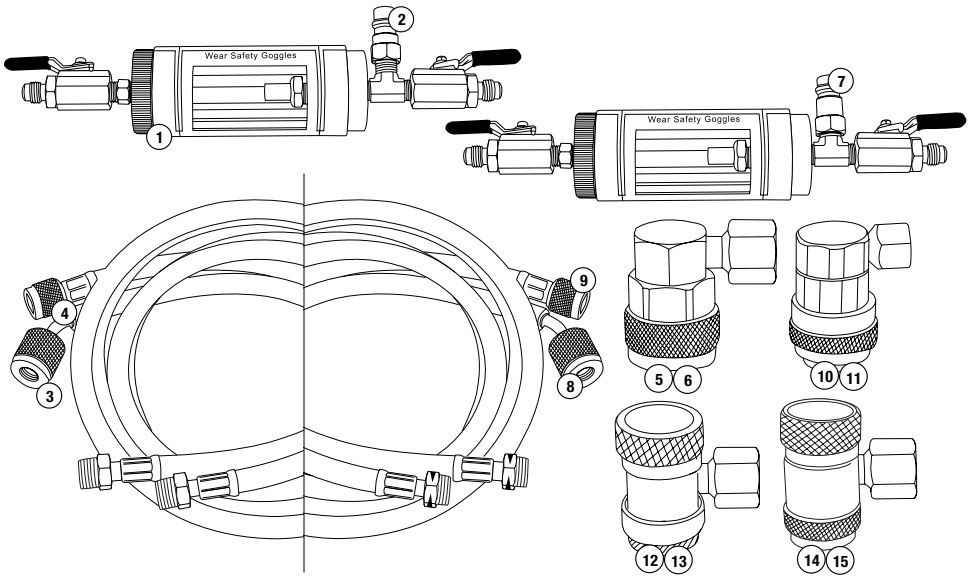

⚠ WARNING: This product can expose you to chemicals including Di (2-ethylhexyl) phthalate, lead and lead compounds, which are known to the State of California to cause cancer and birth defects or other reproductive harm.

View other diagnostic & testing tools made by Mastercool on our website.