

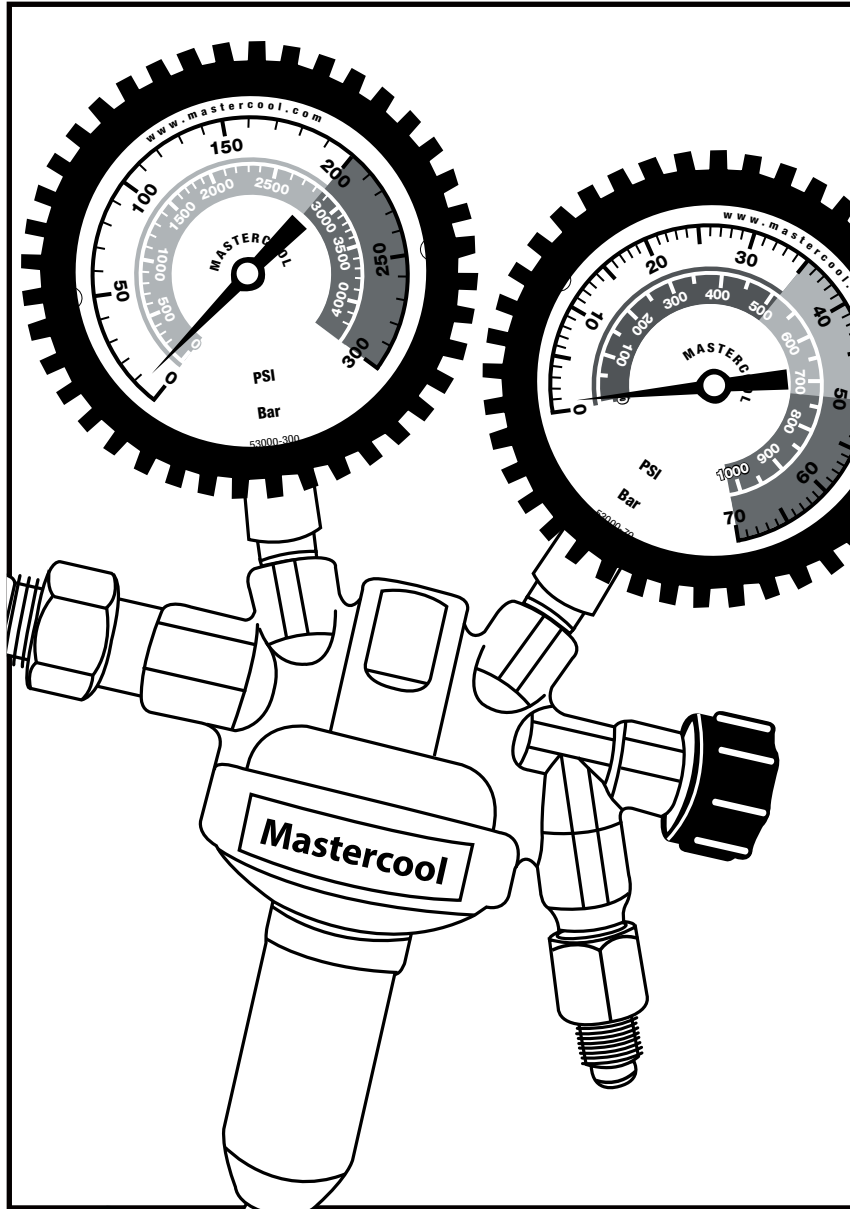

Mastercool[®] Inc.
"World Class Quality"

OPERATING INSTRUCTIONS

NITROGEN PRESSURE REGULATOR LEAK TESTING KIT



NITROGEN PRESSURE REGULATOR LEAK TESTING KIT

- Pressure regulation of Nitrogen (N₂)
- Pressure testing refrigeration systems
- Leak-down testing of refrigeration systems
- Purging of refrigeration systems
- Only for use on nitrogen pressure cylinders

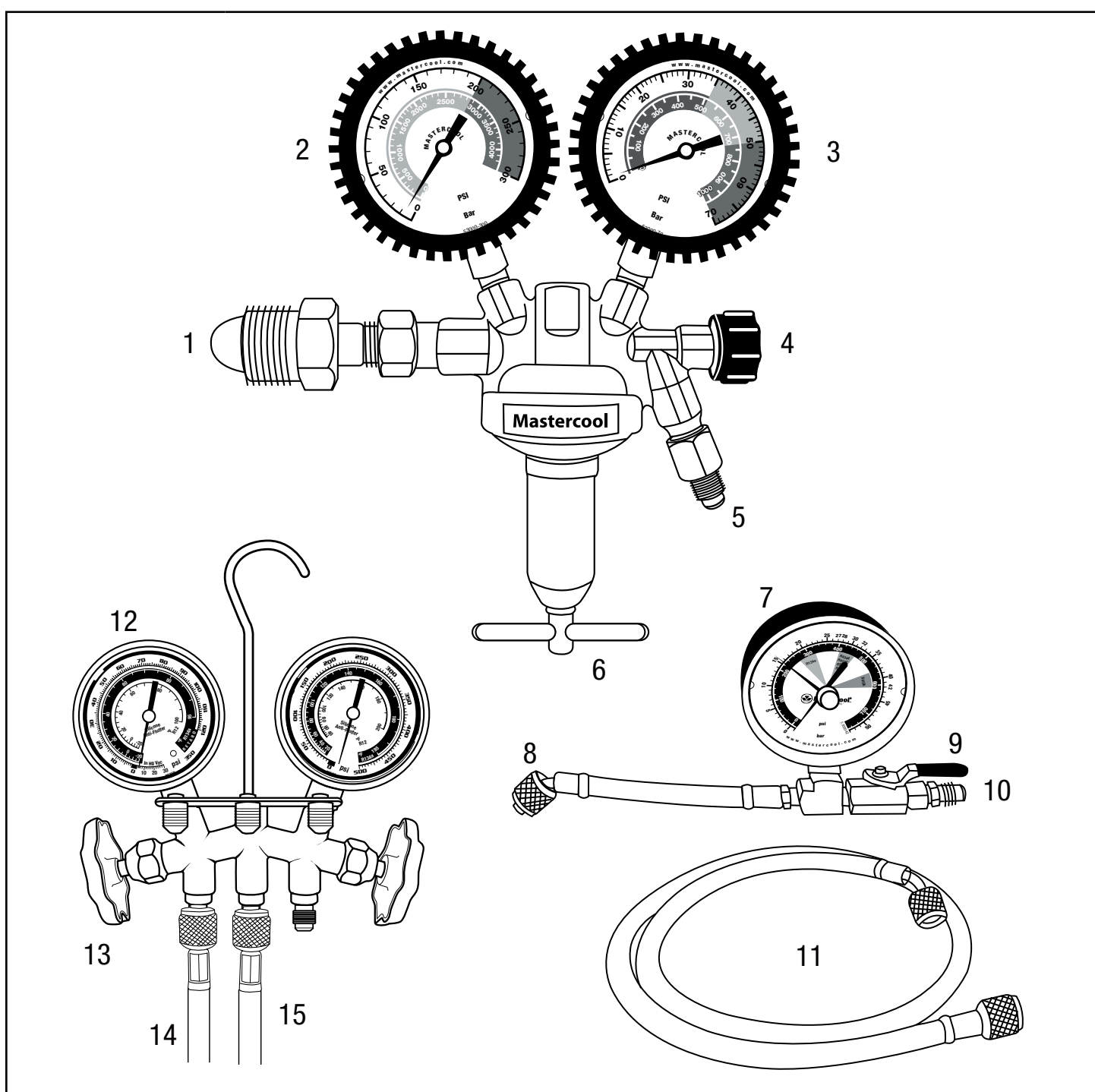

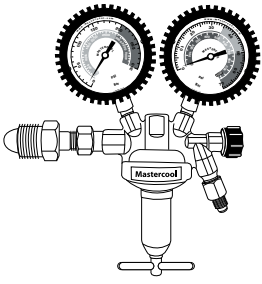
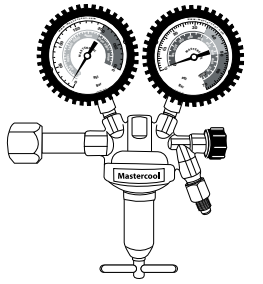
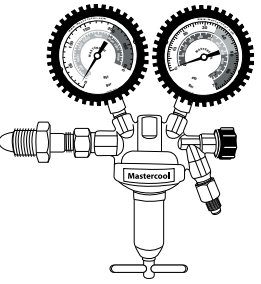
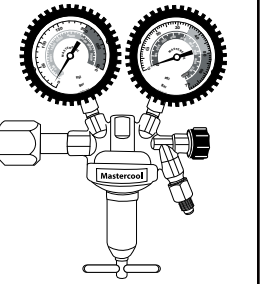
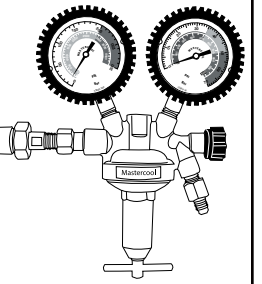
				
53001 CGA580 (US)	53002 DIN477#6 & DIN477#10 (includes adapter to convert DIN477#6 to DIN477#10 (France/Germany))	53003 BS3 (England)	53004 AS2473.2 (Australia)	5-UNI11144 (Italy)

No.	Description
1.	Cylinder Connection
2.	High Side Gauge of Nitrogen Regulator (input)
3.	Low Side Gauge of Nitrogen Regulator (output)
4.	Output Control Valve
5.	Charging Hose Connection on Regulator
6.	Pressure Regulator T Handle
7.	Leak Testing Gauge Assembly
8.	Connection to Refrigeration System
9.	Leak Testing Ball Valve Lever
10.	Charging Hose Connection on Leak Testing Assembly
11.	Charging Hose
12.	Charging and Testing Manifold (not included in kit)
13.	Low Side Valve on Manifold
14.	Low Side Hose (blue)
15.	Charging Hose (yellow)

TECHNICAL DATA:

Connection:

- Model # 53001: CGA580 (US)
- Model # 53002: DIN477#6 & DIN477#10 (includes adapter to convert DIN477#6 to DIN477#10 (France/Germany))
- Model # 53003: BS3 (England)
- Model # 53004: AS2473.2 (Australia)

Pressure Regulator:

- 100 - 4500 PSI (7 - 300 Bar) High side
- 30 – 1000 PSI (2 – 70 Bar) Adjustment range
- Integrated Shutoff Valve

Safety Relief Valve: 725 PSI (50 Bar)

Gauge Diameter: 2 5/8 (68 mm) Not including guard

WARNINGS



- Only use with nitrogen gas (N2).
- The regulator is not to be used with liquid nitrogen.
- Do not modify the regulator. Doing so could result in personal injury.
- Do not over-pressurize the regulator. This could cause leakage, part damage or personal injury due to bursting of pressure-containing parts.
- Keep the regulator clean and free of oil.
- Do not use a damaged regulator. Except for replacing the gauges, do not attempt to repair the regulator.
- Failure to follow instructions can result in personal injury and/or damage to the equipment.
- Do not install this regulator where service conditions can exceed the specifications of any applicable local, state, or federal codes and regulations.
- Wear safety glasses and gloves.

REGULATOR CONNECTION AND USE

Note: The nitrogen regulator can be used with a charging hose and leak testing gauge assembly or a charging and testing manifold.

- Make sure the cylinder connection (1) is clean and free from damage.
- Turn the T handle (6) all of the way out (counter clockwise, looking from the bottom).
- Open the output control valve (4) to release any pressure, and then close it.
- Install the nylon gasket or O-ring, if the connection requires one.
- Install the regulator onto the cylinder. Do not over tighten the nut on gasketed connections.
- Connect the yellow charging hose (11) from the regulator to the leak testing gauge assembly, making sure the ball valve connection (9) is closed.
(If using a manifold, connect the yellow charging hose (15) of the manifold to the regulator.)
- Connect the other end of the leak testing gauge assembly (8) to the system.
(If using a manifold, connect the low side hose (14) from the manifold to the system.)
- Slowly open the cylinder valve. The high side gauge (2) should read the cylinder pressure.
- Adjust the regulator pressure by turning the T handle (6) clockwise until the required pressure (based on the system's refrigerant) is shown on the low side (output) (3) pressure gauge.

NOTE: This is a non-reliving regulator. To adjust the output pressure lower, some nitrogen will have to be released from the output (e.g. with no hoses connected, turn the T handle counter-clockwise, then open the output control valve and close it. The output gauge should read a lower pressure.)

- If using the leak testing gauge assembly, turn the red needle to the required refrigerant pressure.

Testing Range of Systems		
R134a	260 - 320 psi	18 - 22 bar
R404A	405 - 465 psi	28 - 32 bar
R404C	405 - 465 psi	28 - 32 bar
R507	405 - 465 psi	28 - 32 bar
R22	405 - 465 psi	28 - 32 bar
R410A	550 - 610 psi	38 - 42 bar

- Open the output control valve (4) and open the ball valve (9) on the leak testing gauge assembly for the nitrogen to flow into the system.
(If using a manifold, open the output control valve (4) and the low side valve (13) on the manifold.)
- Make sure the required pressure is available on both gauges. (You may need to turn the T handle (6) on the regulator to adjust to the required pressure.)
- Once the pressure is equalized (make sure the black needle is aligned with the red marker on the leak testing gauge assembly) close the ball valve connection (9).
(If using a manifold, close the low side valve (13) on the manifold making note of the pressure when the valve is closed.)

- Close the output control valve (4) on the regulator
- Disassemble the yellow charging hose (11) from the regulator and leave the system for a period of time (time is based on the size of the system.)
- After some time, look at the gauge, if there is a leak in the system the pressure will have dropped from the original setting.

REGULATOR REMOVAL

- Turn the cylinder valve off.
- Relieve the pressure on the regulator by opening the output control valve (4). Both gauges should read zero.
- Slowly loosen the cylinder connection. There may still be some pressure between the regulator and cylinder.
- Completely remove the regulator.
- Clean and store the regulator in its box to prevent damage.

⚠ WARNING: This product can expose you to chemicals including lead and Di (2-ethylhexyl) phthalate, which are known to the State of California to cause cancer and birth defects or other reproductive harm.

View [other diagnostic & testing tools](#) made by [Mastercool](#) on our website.