

Installation Instructions

Heavy Duty T-Bracket

Please read this entire instruction sheet before working on your vehicle and observe the following safety considerations at all times while installing the T-Bracket:

Wear safety glasses at all times during installation!

Carefully examine behind any drilling location for any electrical wiring. Use a drill stop if necessary to prevent drill bits from penetrating roof or side body panels.

STEP 1

Mark four pilot holes in the upper side rib using the T-Bracket (Item 1) as a template. Remove the T-Bracket and drill 3/8" pilot holes. Install (4) PRE-BULB PLUSNUTS (Item 2) in the 3/8" pilot holes. Use a 1/4-20 X 2-1/2" screw (Item 4) to set the plusnut. See Figure 1 for detailed PLUSNUT installation.

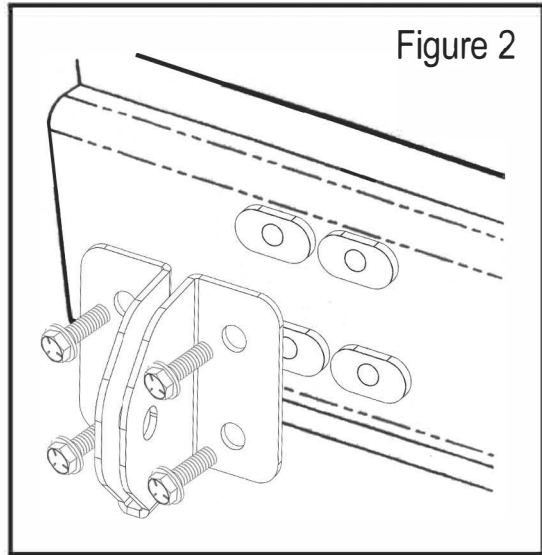
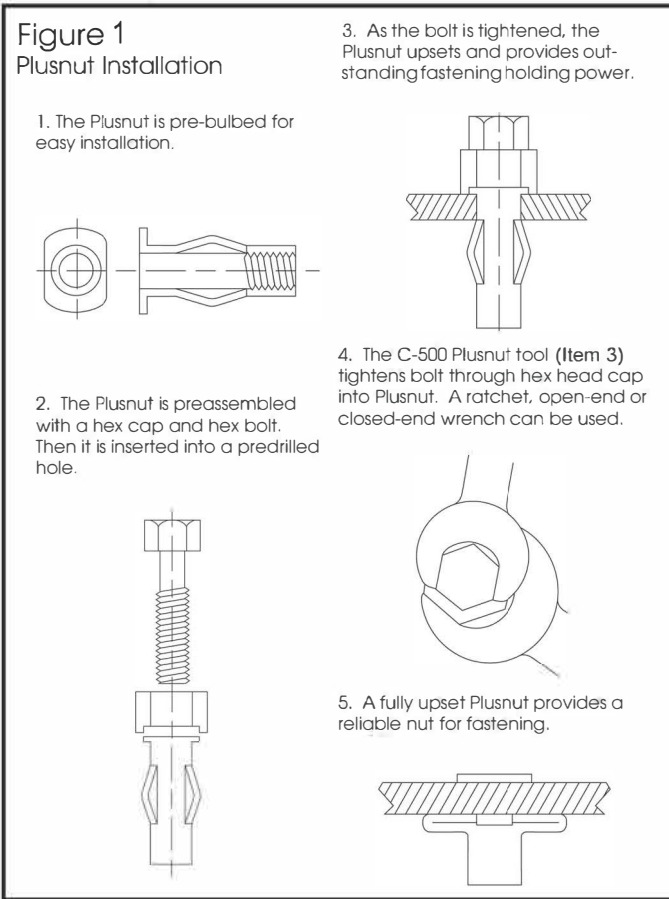

STEP 2

Attach the T-Bracket using (4) 1/4-20 X 3/4" screw (Item 5). See Figure 2.

STEP 3

Connect the attachment brace through the middle of the T-bracket using (1) 1/4-20 X 3/4" screw and (1) 1/4-20 elastic stop nut. See Figure 3.

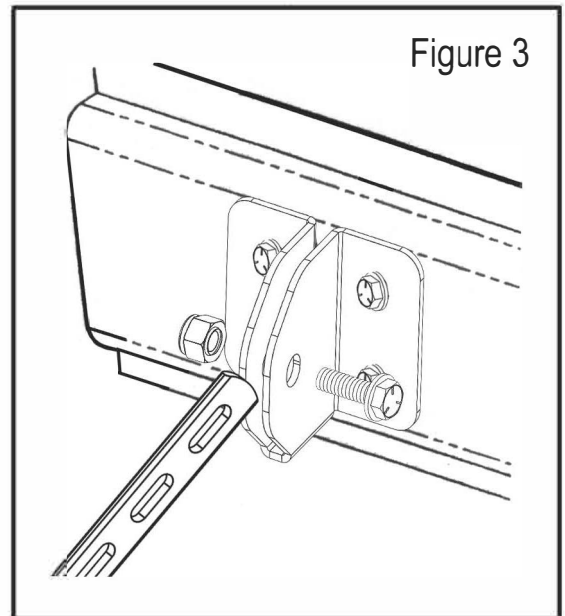

PARTS LIST

Components

ITEM	QTY	DESCRIPTION
1	6	Heavy Duty T-Bracket

Hardware

ITEM	QTY	DESCRIPTION
2	24	Plusnuts
3	1	Plusnut Tool
4	1	1/4-20 x 2 1/2" Grade 8 HWH Bolt
5	24	1/4-20 x 3/4" Grade 5 HWH Screw

Required Tools

Electric Drill
 3/8" drill bit
 3/8" drill stop
 7/16" wrench or socket