



TAILOR FIT FOR A JOB DONE RIGHT

General Instruction Booklet

Steel Storage Modules

Caution:

Review all installation instructions before proceeding with the assembly.

Always check before drilling any holes to make sure no wiring or fuel lines will be damaged. Serious injury can result.

General Hardware bags are included, pieces may be leftover.

General Assembly: start at the bottom and work up. Storage doors are to be installed last.

Build module, tighten, then mount to vehicle. Tightening before module is complete may misalign parts.

Under no circumstances should any flammable or combustible materials be stored in cabinets or enclosures.

Wear Safety glasses at all times during assembly and installation.

Form Number: RM470612
Rev.

Toolbox Storage Door

Attach a front floor brace upside down to the uprights using the 13th hole from the bottom with (2) 1/4 - 20 x 3/4 screws and (2) 1/4-20 stop nuts. Attach shelf to uprights just above the upside down floor brace. Attach tool box door to the lower floor brace with (4) 1/4 - 20 x 3/4 screws and 1/4-20 stop nuts.

Figure 19

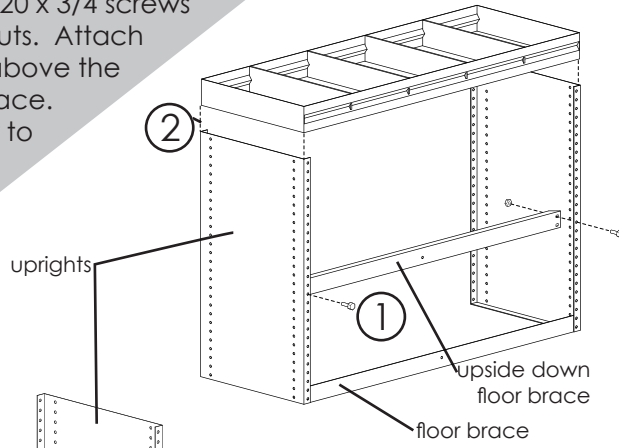
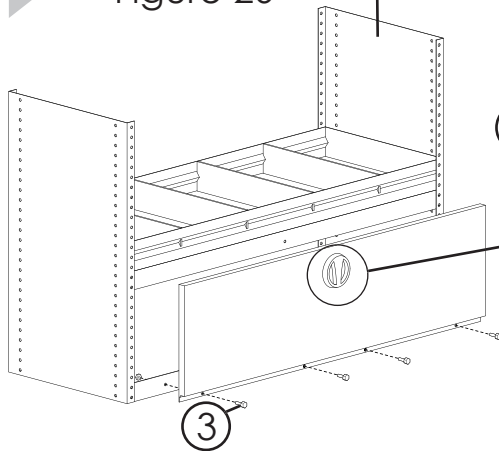

Figure 20



Sliding Drawer Storage

Locate shelf at desired height. Attach shelf with (4) 1/4-20 x 3/4 screws and (4) 1/4-20 stop nuts with one screw in each corner from the front and one screw in each corner from the back.

Figure 23

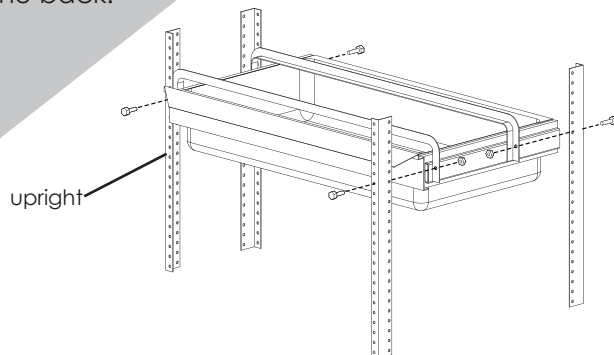
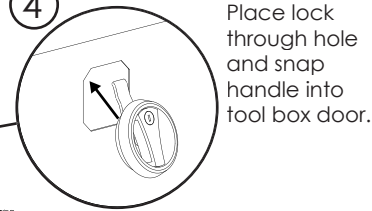

Figure 21



Worktop and Key Machine Base

Attach braces of worktop through top holes of uprights with (4) 1/4 - 20 x 3/4 screws and (2) 1/4-20 stop nuts.

Figure 24

To attach Key Machine Base; mark and pre-drill 5/16" holes in work top. Attach with a 1/4-20 x 1-1/4 screw, (2) 1/4 washers, and (1) 1/4-20 stop nut in each corner.

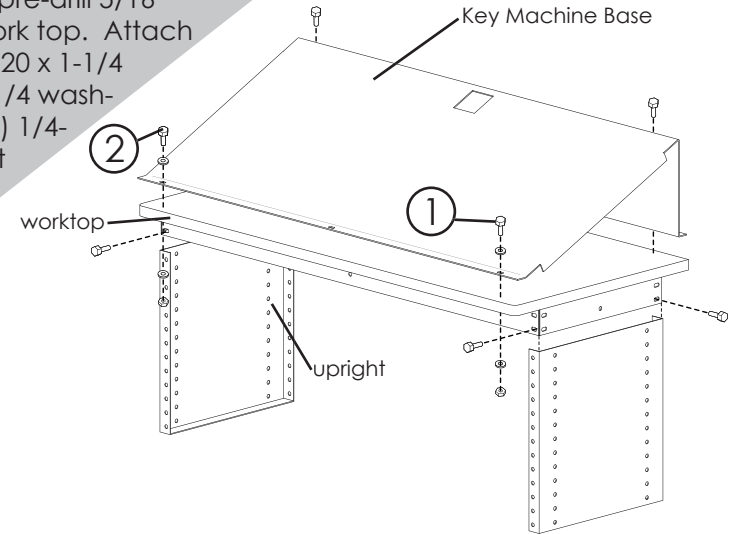

Plus nut Installation

Locate and mark hole on vehicle upper structural beam. Use a 3/16" drill bit to drill a pilot hole at each mark. Enlarge 3/16" hole with drill stop set for 1/2" penetration. Set up hardware as shown and push plus nut into drilled hole. Use wrench to tighten screw while holding plus nut tool in place with another wrench.

Figure 25

Use 1/4-20 plus nuts for BOTH wall mounting and floor braces located above the fuel tank.

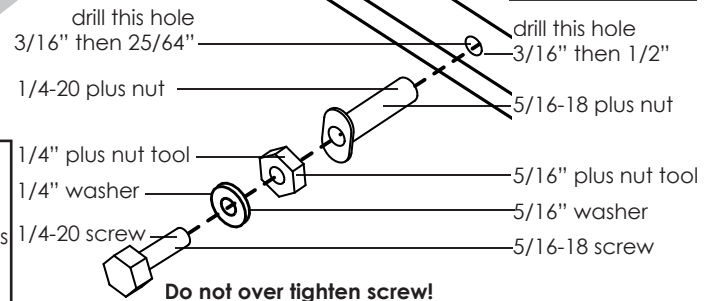

Use 5/16-18 plus nuts for mounting uprights ONLY above the fuel tank.

Vehicle installation

Place modules inside van and square to floor. Attach brace loosely at or near the top of the module at each end. Use brace to mark hole. Detach brace while drilling hole. Reattach brace to module and tighten 1/4-20 x 3/4 screws. The end of the brace may be removed to eliminate overhang.

Figure 26

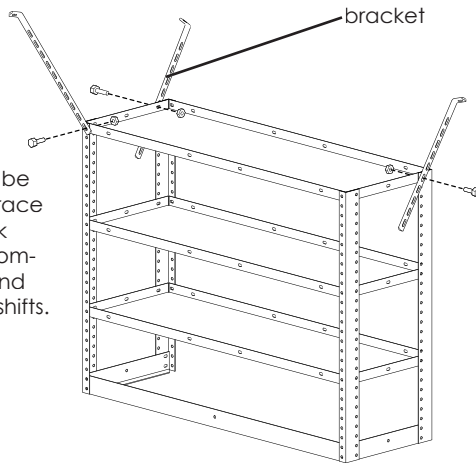

Modules must also be attached with a brace to the front or back van ceiling to accommodate forward and backward weight shifts.

Figure 27

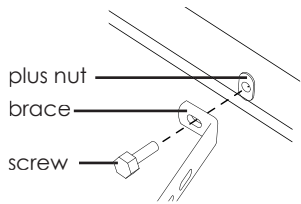

Alternate ways to attach brace

To fit the braces to the uprights and contours of the vehicle a vice may be used to bend the braces accordingly. This is acceptable when the generic installation method fails to work for your application.

Figure 28

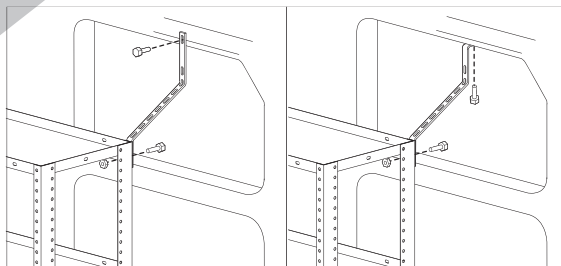

Parts Drawer and Tilt Shelf

Parts Drawer Cabinets depend on the rearward tilt of the shelf to keep the drawers closed. Attach the tilt shelf to the uprights in the front and back using (4) 1/4 - 20 x 3/4 screws and (4) 1/4-20 stop nuts. Remove two drawers from the cabinet to reveal pre-punched holes. Attach to the shelf using (4) 1/4 - 20 x 3/4 screws

Figure 17

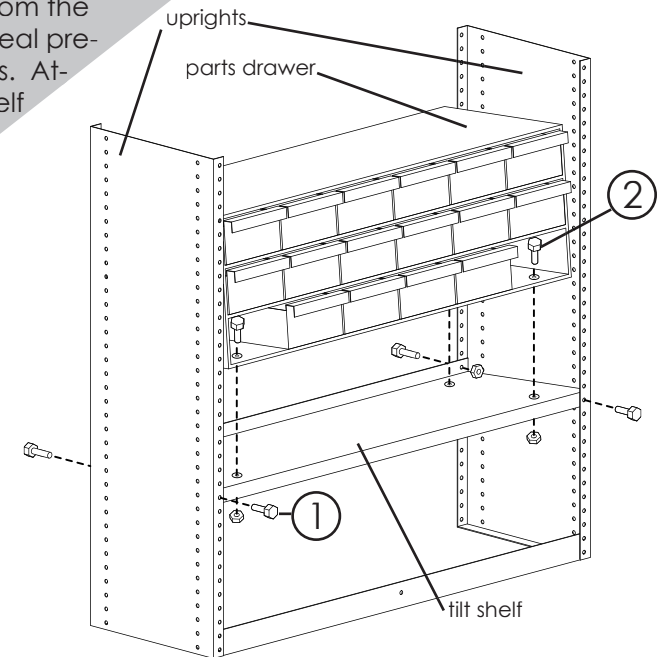

J Hooks and Triple Hooks

Locate the hook at the desired height and attach to upright with (2) 1/4 - 20 x 3/4 screws and (2) 1/4-20 stop nuts. J Hooks may be attached to front or sides of upright. J Hooks also attach to van wall using a 1-1/4 screw and plus nut (see Figure 25 for installation directions).

Figure 18

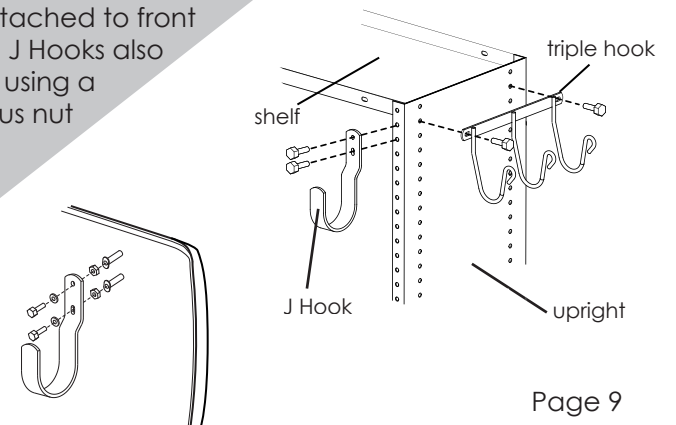

Storage Cabinet Stack

Figure 13

Using a power driver attach brackets (side with holes farther from the edge) to the top side edges of cabinet drawers with (2) self-drilling Type F screws. Place cabinet on top of drawers lining up front faces. Using a power driver and (2) self-drilling Type F screws attach brackets to cabinet.

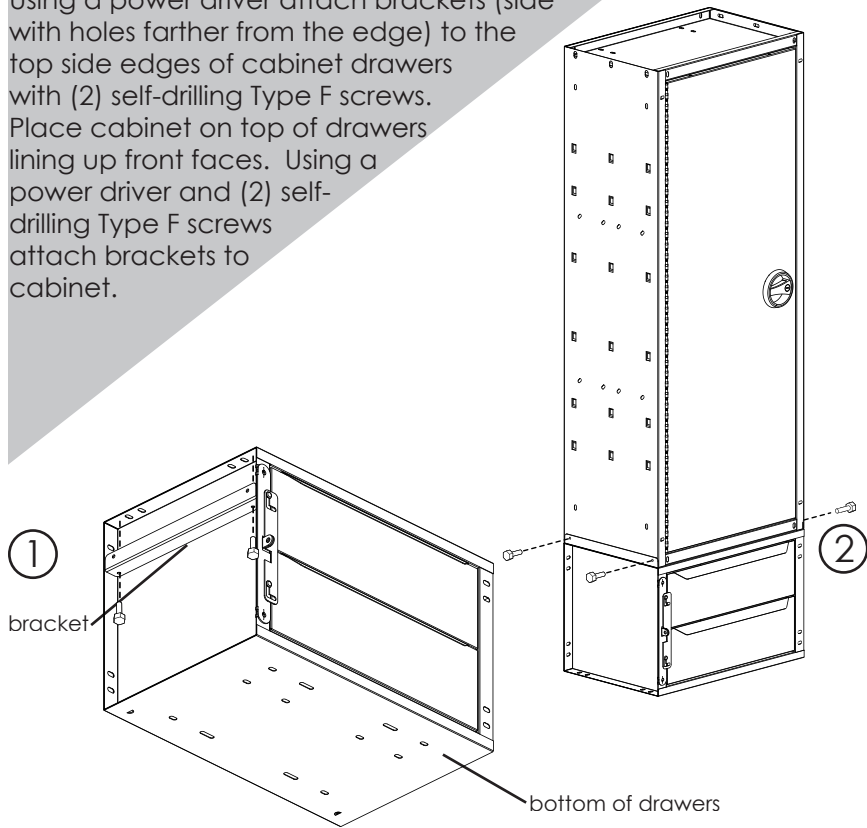

Figure 14

Manual Rack

The manual rack bolts to the upright as shown with (3) 1/4 - 20 x 3/4 screws and (3) 1/4-20 stop nuts along the back side. The rack attaches to the floor with (1) 1/4-20 x 1-1/4 screw.

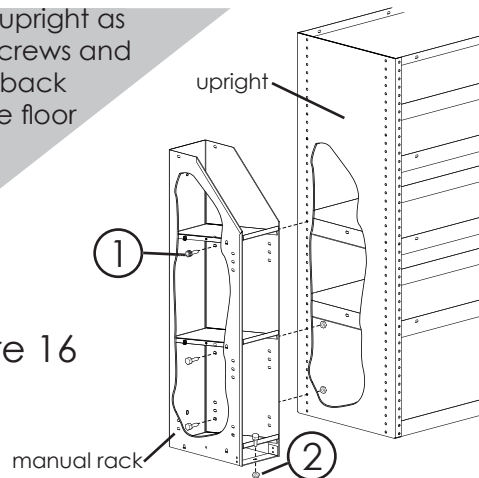

Figure 16

Mounting to vehicle floor

Use the holes in the upright ends and floor brace to mark drilling locations. Attach ends to floor using (2) 5/16-18 x 1-1/4 screws and (2) 5/16" washers from the top and the (2) Sprinter mounting plates and (2) 5/16-18 stop nuts from the bottom.

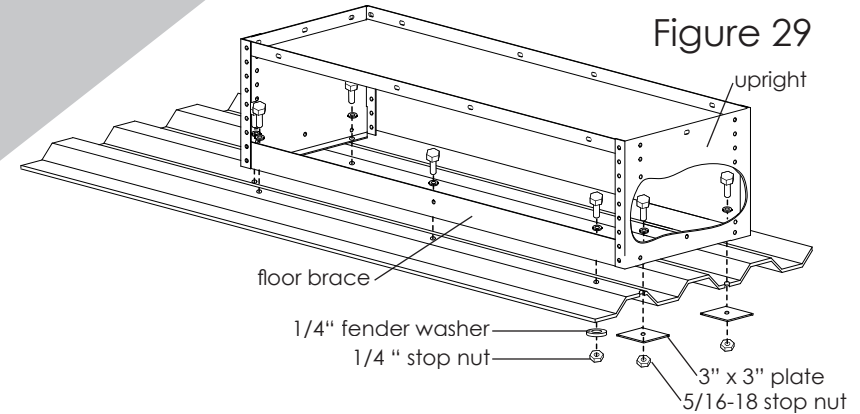

Figure 29

Always check before drilling any holes to make sure no wiring or fuel lines will be damaged. Serious injury can result.

Mounting floor brace

Attach front floor brace to floor using (2-3) 1/4-20 x 1-1/4 screws and 1/4" flat washers from the top and 1/4" fender washer and 1/4-20 stop nuts from the bottom. Obstacles such as fuel lines may prevent drilling through certain areas of the vehicle. It is NOT necessary to use every hole in every brace.

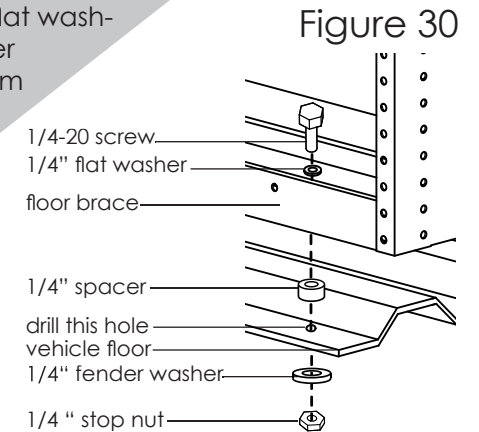
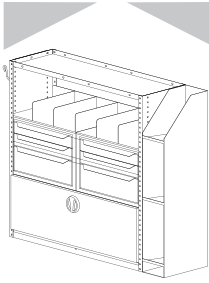
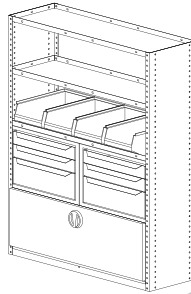

Figure 30

Use a spacer where a screw falls in a valley in the floor of the van to keep module square to floor.



Parts Drawer/Bin Module
Includes manual rack, (2) fixed divider shelves, (2) three drawer cabinets, lockable storage door, and triple hook.
025840
025785
shelving module pg 4, drawer cabinets pg 8, fixed shelf divider pg 8, manual rack pg 10, storage door pg 10



Parts Drawer / Tote Bins
Includes (2) three drawer cabinets, (4) plastic tote bins, lockable storage drawer.
020060 **026450**
022691
shelving module pg 4, drawer cabinets pg 8, storage door pg 10

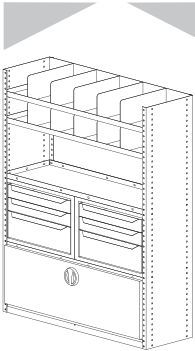

Part Drawer/Bin Module
Includes (2) three drawer cabinets, (2) divider shelves, lockable storage door, and shelf back.
027446
025320
shelving module pg 4, drawer cabinets pg 8, fixed shelf divider pg 6, manual rack pg 8, storage door pg 10

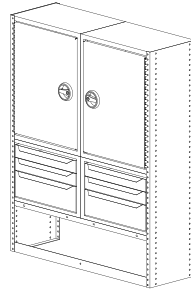

Parts Drawer/Cabinet Module
Includes (2) lockable storage cabinets with shelf, and (2) three drawer cabinets.
027447
025321
shelving module pg 4, drawer cabinets pg 8, storage cabinets pg 7, manual rack pg 8

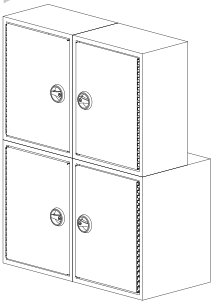

Cabinet Stack Module
Includes (2) 12"D storage cabinets and (2) 18"D storage cabinets. Each cabinet includes a shelf.
022686
storage cabinets pg 7

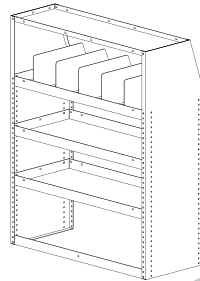

Utility Shelving with Dividers
Includes (5) bolt in shelf dividers.
026803
026802
025783
025839
shelving module pg 4, fixed shelf divider pg 6

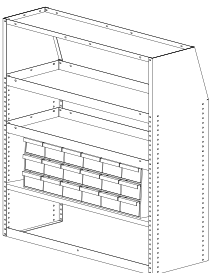

Parts Cabinet/Utility Shelving
Includes tapered shelf module with an 18-drawer parts cabinet and tilt shelf.
026805
026804
shelving module pg 4, tilt shelf pg 9

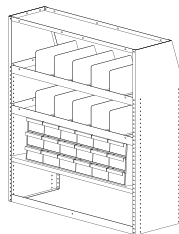

Parts Cabinet with Dividers
Includes tapered shelf module with an 18-drawer parts cabinet, tilt shelf and (10) bolt in shelf dividers.
022684
022685
shelving module pg 4, tilt shelf pg 9, fixed shelf divider

Cabinet Drawers

Place the two J-Clip Nuts on the left edge of the cabinet over the top most slots and lower most slots.

Place the cabinet on top of the shelf. Remove bottom drawer. Secure the cabinet to the shelf using (4) 1/4-20 x 3/4 screws and 1/4-20 stop nuts.

Figure 10

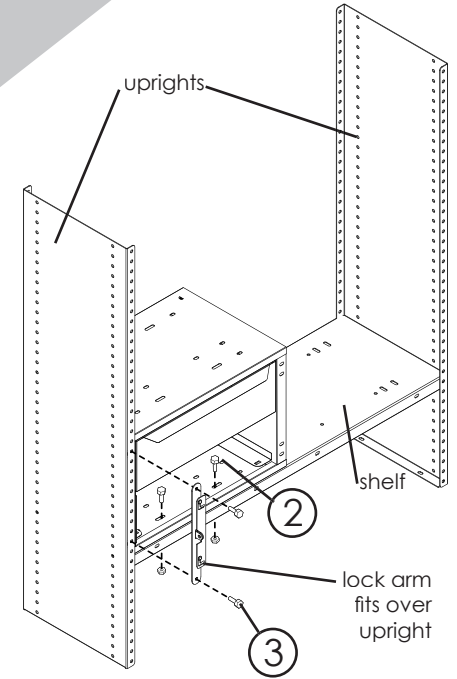
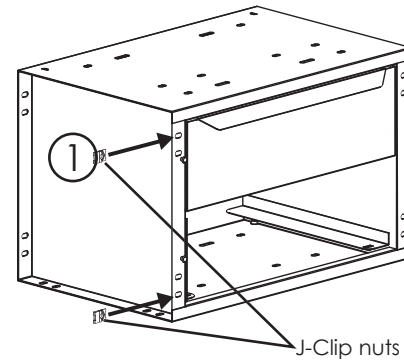

Figure 11



Cabinet Drawers Lock Arm

Attach the Lock assembly to the left front of the cabinet into the J-Clip Nuts using two 1/4-20 x 3/4" hex head screws.

Figure 12

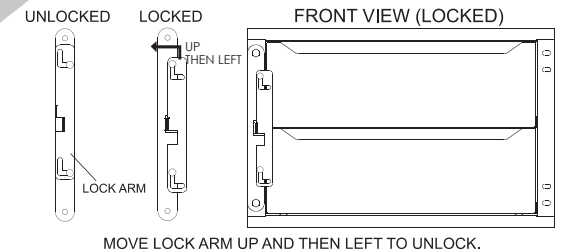

Parts Tray Shelves (adjustable)

Locate parts tray at desired height and bolt into upright assembly as shown using 1/4 - 20 x 3/4 screws and 1/4-20 stop nuts. Insert adjustable dividers as shown.

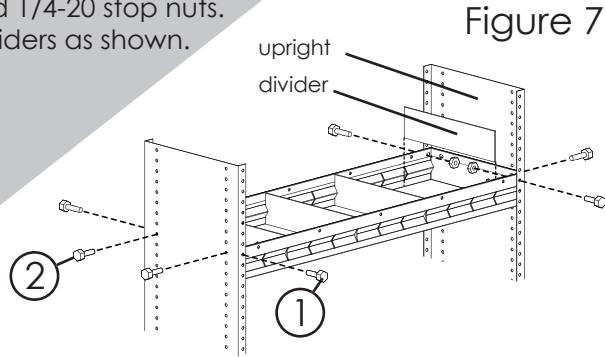

Figure 7

Divided Shelves (welded)

Locate divided shelf at desired height and bolt into upright assembly as shown using 1/4 - 20 x 3/4 screws and 1/4-20 stop nuts.

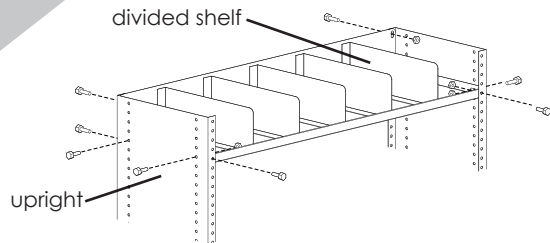

Figure 8

Fixed Shelf Divider (bolted)

Use (2) 1/4 - 20 x 1/2 screws and (2) 1/4-20 stop nuts to attach each divider to fixed shelf.

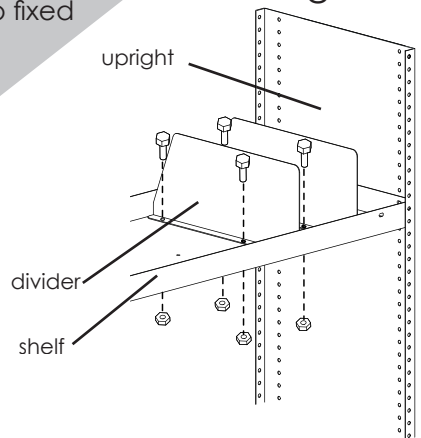
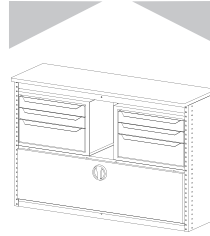
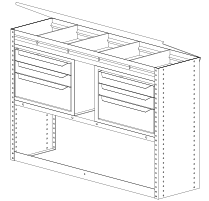

Figure 9



Workbench Module

Includes (2) three drawer cabinets, lockable storage door, and a durable worktop surface.
022707
022706
 shelving module pg 4, drawer cabinets pg 8, worktop surface pg 11



Parts Tray/Parts Drawers

Includes (2) three drawer cabinets, parts tray with movable dividers, and a hinged worktop lid.
022700
022701
 shelving module pg 4, drawer cabinets pg 8, worktop surface pg 11

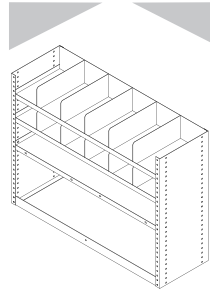

Divided Shelf Storage Module

Includes (2) fixed divider shelves, and a flat storage shelf.

020066
020065

shelving module pg 4, fixed shelf divider pg 6

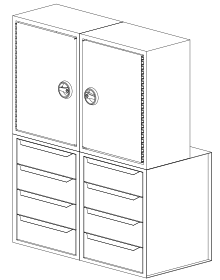

Cabinet/Drawer Stack

Includes (2) large drawer cabinets and (2) 12"D lockable storage cabinets with adjustable shelf.

027448

drawer cabinets pg 8, storage cabinets pg 7

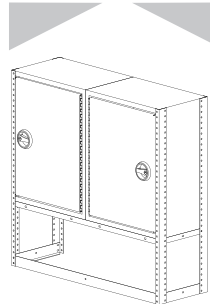

Dual Cabinet Storage Module

Includes (2) lockable storage cabinets with adjustable shelf.

020061
021403

shelving module pg 4, storage cabinets pg 7

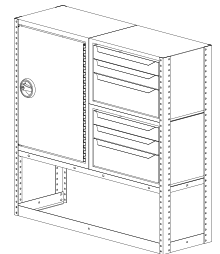

Cabinet/Parts Drawer Module

Includes a locking storage cabinet with adjustable shelf, and (2) three drawer parts cabinets.

025520
022704

shelving module pg 4, drawer cabinets pg 8, storage cabinet pg 7

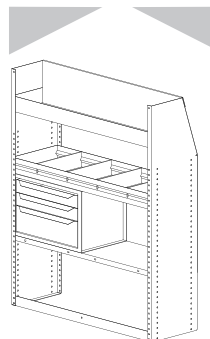

Utility Shelf/Parts Drawer

Includes tapered parts tray module, with three drawer parts cabinet and deep lip top tool tray.

027278
027449 **027450**

shelving module pg 4, parts tray shelf pg 6, shelf dividers pg 8

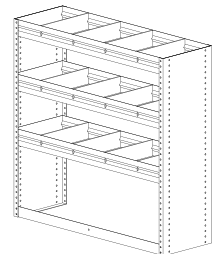

Parts Tray Modules

Includes 3" deep parts trays with movable dividers.

026801 **022262** **022264** **027374**
022263 **022265** **027451** **027452** **027453**

shelving module pg 4, parts tray shelves pg 9

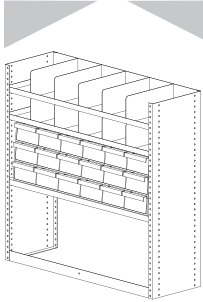

Divided Shelf/Parts Cabinet
Includes (2) divider shelves and an 18 drawer parts cabinet with tilt shelf.
020069
022703
shelving module pg 4, drawer parts cabinets pg 9, fixed shelf divider pg 6

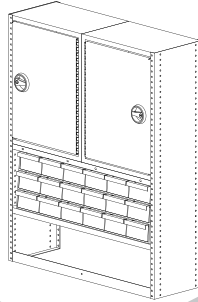

Storage Cabinet/Parts Cabinet
Includes (2) lockable storage cabinets, and an 18 drawer parts cabinet with tilt shelf.
027459
shelving module pg 4, drawer parts cabinets pg 9, storage cabinet pg 7

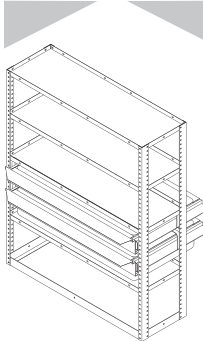

Drawer Storage Module
Includes a 3"H x 18"D drawer, a 6"H x 18"D drawer, and shelves.
027510 021400
021399
shelving module pg 4, sliding drawer storage pg 10

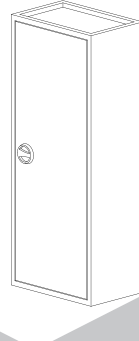

Lockable Storage Cabinet
Includes adjustable shelf and locking handle.
021392 024514 026188 022466 025841
Additional Shelves **027555 027586 027673**
storage cabinets pg 7

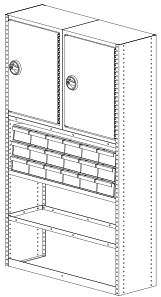

Storage Cabinet/Parts Cabinet
Includes (2) lockable storage cabinets and an 18 drawer parts cabinet with tilt shelf.
026451
shelving module pg 4, parts cabinet pg 9, storage cabinets pg 7

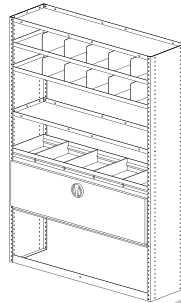

Divided Shelf/Parts Tray
Includes (2) fixed divider shelves, a parts tray with movable dividers and a lockable storage door.
027460
026432
shelving module pg 4, fixed shelf divider pg 6, parts tray shelf pg 6, storage door pg 10

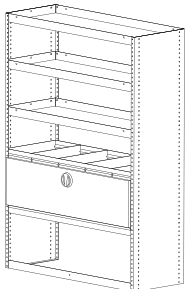

Utility Shelf/Parts Tray Module
Includes a parts tray with movable dividers, a lockable storage door, and utility shelving
027461 026443 027462 26431
027477 027470 027471 026435 027472
shelving module pg 4, parts tray shelf pg 6, storage door pg 10

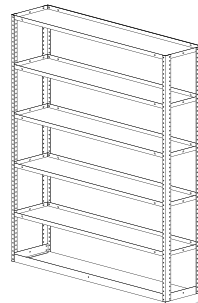

Utility Shelving with Back Panel
Open End shelving with back panel retainer.
027463
027464
026452
open end shelving module pg 4

Adjoining Shelves

Two or more modules placed side by side should share common screws so that screw heads will not cause a gap between the modules. Connect the modules using a single screw-stop nut combination through each shelf and upright as shown. Use (1) 1/4-20 x 3/4 screw and (1) 1/4-20 stop nut in shelf

Figure 4

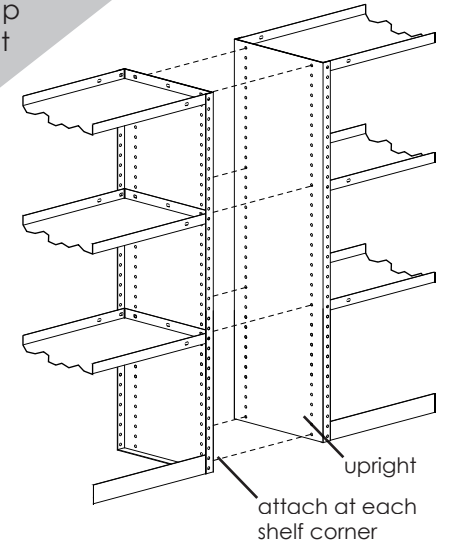
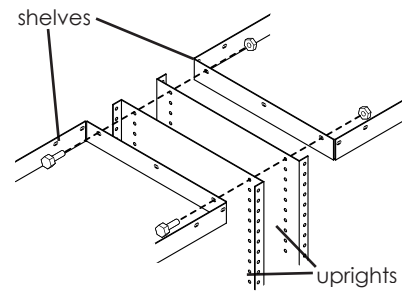

Figure 5 detail



Hinged lid

Attach parts tray lid to parts tray using (5) 10/24 x 1/2" phillips pan head machine screws and (5) 10/24 elastic stop nuts.

Figure 6

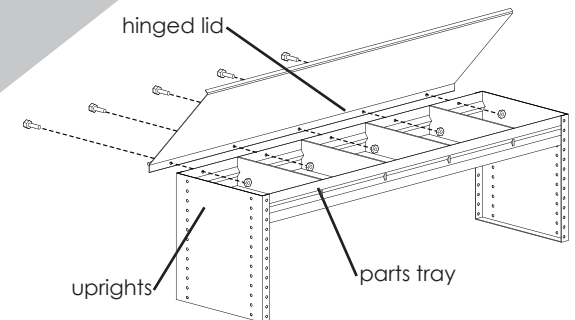

Solid End Brace

Attach floor brace to solid upright set (flanges to the inside) using (2) 1/4 - 20 x 3/4 screws and (2) 1/4-20 stop nuts on each side.

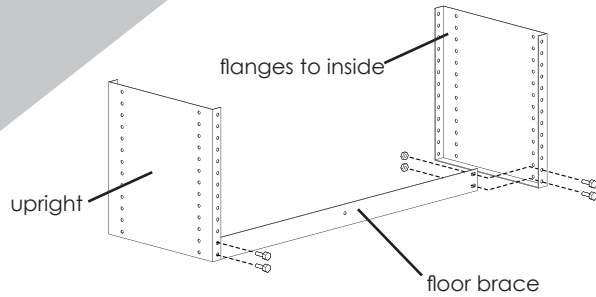

Figure 1

Open End Braces

Upright assemblies for open end shelving consist of (4) vertical uprights of equal height, (1) long floor brace (front) and (2) short floor braces (sides). All floor braces attach to the bottom of the uprights as illustrated using (2) 1/4 - 20 x 3/4 screws and (2) 1/4-20 stop nuts on each side.

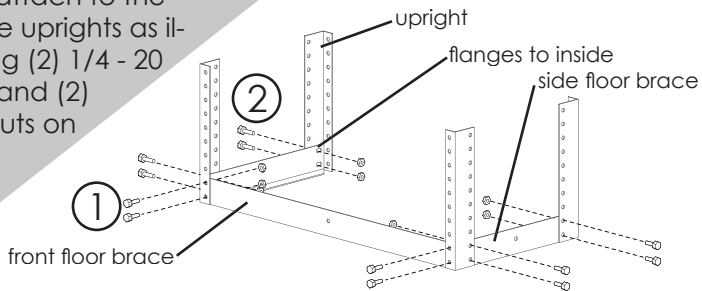

Figure 2

Fixed Shelf

Locate shelf flange up at desired height (if it is the bottom shelf and a 1" shelf, then install no lower than the 13th hole from the bottom to fit over a wheel well, for 2" shelves use 14th hole). Use (2) 1/4 - 20 x 3/4 screws and (2) 1/4-20 stop nuts on each corner.

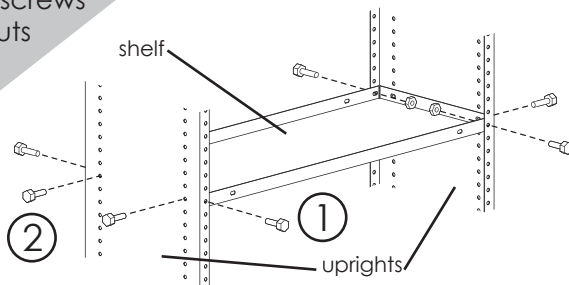

Figure 3

Cabinet/Drawer Stack

Includes a tall locking storage cabinet and a three drawers parts cabinet.

026434

drawer cabinets pg 7, storage cabinet pg 8

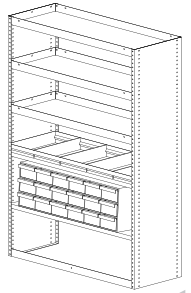
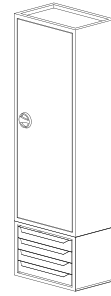

Utility Shelving/Parts Cabinet

Utility shelving module with a parts tray and an 18 drawer parts cabinet with tilt shelf.

027469
026436

shelving module pg 4, tilt shelf pg 9,
drawer parts cabinets pg 9, parts tray shelf pg 6

Utility Shelving/Parts Drawer

Utility shelving module with (2) three drawer cabinets and lockable door.

027467
027468

shelving module pg 4, drawer cabinet pg 8,
storage door pg 10

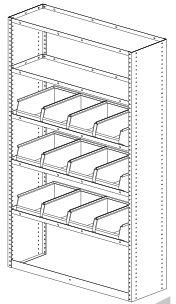
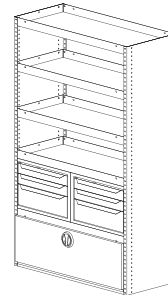

Utility Shelving/Tote Bins

Utility Shelving Module with plastic tote bins.

026446 026448 027465
026447 026449 027466

shelving module pg 4

Utility Shelving/Parts Tray Module

Utility shelving with parts trays

026444 026442 027473
027474 026445 027475

shelving module pg 4, parts tray shelves pg 6

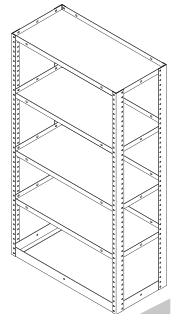
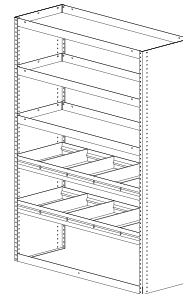

Open Ended Shelving

12", 16", and 22" Open End Shelving

021398 026441
021410 thru 021426
027514 thru 027558

(excluding **027524** and **027531**)
open end shelving module pg 4

Solid End Shelving Module

12" and 16" Solid End Shelving

022821 thru 022826
022831 thru 022842
027559 thru 027574
027524 and 027531

shelving module pg 4

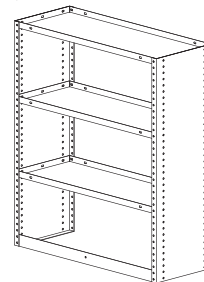

Tapered Solid End Shelving Module

12" and 16" Tapered End Shelving

022432 022433 022434 022817
025591 027538 027545 027546

shelving module pg 4

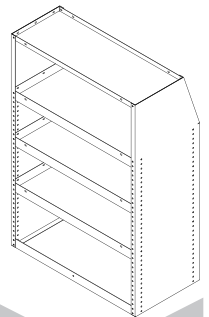



Heavy Duty Uprights for Open End Shelving
 Can be used with 12", 16", and 22" deep shelves.
 Requires floor braces. Sold as set of four uprights.
020031 021368 021369
025336 025366 026440

shelving module pg 4

Solid End Uprights
 Sold as a set of two uprights.

022347 022348 022455 022473 022957
025367 025948 026438 026439

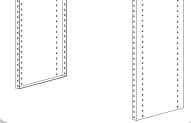

shelving module pg 4

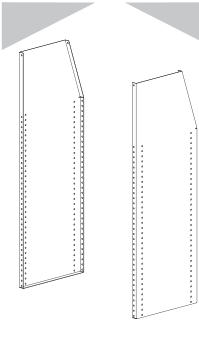

Tapered Uprights
 Use with 16" deep shelves, 12" top shelf. Sold as set of two.

022395

shelving module pg 4

Steel Shelves
 12" deep shelves with 1" lip. 16" deep shelves with 2" lip.
 Standard
021377 thru 021382 025153 022816 022396 thru 022398
 Heavy Duty
025313 thru 025319 025326 025571 025572 027483

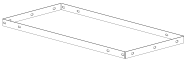

shelving module pg 4

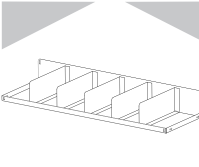

Divided Shelves
 Steel shelf back and welded vertical dividers.

020024

fixed shelf divider pg 6

Parts Tray Shelves
 3" deep lip, each shelf includes snap in dividers.
021389 022215 022898 025815 025842
025858 025859 025877 026486 027478
 Dividers (4 pack) **021391 027547**

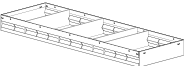

parts tray shelf pg 6



Braces
Side Braces(for heavy duty uprights, open end set of 2)
023054 022613 025335
Front Braces(for all models)
023055 thru 023059 025680

shelving module pg 4

Tilt Shelves
 Heavy gauge to support parts cabinets. Tilts back to keep drawers closed during transit.

020043 022531 022532 022340 022482 025072



shelving module pg 4

Contents

shelves

solid end braces	pg 4
open end braces	pg 4
fixed shelf	pg 4
adjoining shelves	pg 5
parts tray shelves (adjustable)	pg 6
divided shelves (welded)	pg 6
fixed shelf divider (bolted)	pg 6

cabinets

storage	pg 7
drawer (2-4 drawers)	pg 8
drawer parts (6-24 drawers)	pg 9
tilt shelves	pg 9

Miscellaneous

manual rack	pg 8
triple hooks	pg 9
J hooks	pg 9
toolbox storage door	pg 10
sliding drawer storage	pg 10
worktop	pg 11
hinged lid	pg 5
key machine base	pg 11
Mounting to vehicle	pg 11-13

Index

pg 14-19

Recommended Tools

Power Drill	Hacksaw	Hammer Center Punch
Drill stop	Vise	Marking Pencil
Drill bits	Pliers	Straight Edge
1/2", 7/16", and 7/8"	Utility knife	Phillips Screwdriver
Wrenches	Pop rivet setting tool	
1/2" and 7/16" Socket with Driver	C clamp	
Safety Glasses		

Parts List

28" & 36" Module Hardware Bag

Item	Qty	Description
1	2	Top Attachment Bracket
2	1	Screw 1/4-20x2-1/2" Hex HD G8
3	24	Screw 1/4-20x3/4 7/16 Hex Washer
4	6	Screw 1/4-20x1-1/4 7/16 HWH
5	6	Plus Nut Pre-bulb 1/4-20 Grade 2
6	1	Plus Nut tool 1/4 #C500-25
7	24	Nut 1/4-20 E-stop
8	4	Ford ESN/Washer Combo
9	4	1" x 3/8" Collar

46" Module Hardware Bag

Item	Qty	Description
1	3	Top Attachment Bracket
2	1	Screw 1/4-20x2-1/2" Hex HD G8
3	32	Screw 1/4-20x3/4 7/16 Hex Washer
4	7	Screw 1/4-20x1-1/4 7/16 HWH
5	7	Plus Nut Pre-bulb 1/4-20 Grade 2
6	1	Plus Nut tool 1/4 #C500-25
7	32	Nut 1/4-20 E-stop
8	4	Ford ESN/Washer Combo
9	4	1" x 3/8" Collar

60" Module Hardware Bag

Item	Qty	Description
1	3	Top Attachment Bracket
3	44	Screw 1/4-20x3/4 7/16 Hex Washer G5
4	3	Screw 1/4-20x1-1/4 7/16 HWH G8
5	3	Plus Nut Pre-bulb 1/4-20 Grade 2
6	1	Plus Nut tool 1/4 #C500-25
7	44	Nut 1/4-20 E-stop
9	4	1" x 3/8" Collar
10	4	Plus Nut Pre-bulb 5/16-18 Grade 2
11	1	Plus Nut tool 5/16 #C500-31
12	4	Mounting Washer 3"x3"
13	4	Screw 5/16-18x1-1/4" Hexcap Grade8
14	1	Screw 5/16-18x2 HHC Grade 5
15	4	Nut 5/16-18 Prevailing Torque
16	4	Washer USS 5/16

Cabinet Stack Module Hardware Bag

Item	Qty	Description
10	2	Top Attachment Bracket
11	4	Plate - Attach 2.25"x1.5"
12	8	Sheet Metal Screw #10 x .75
13	8	Screw 1/4-20x3/4 7/16 Hex Washer
14	8	Nut 1/4-20 E-stop
15	8	Washer 1/4 Ext Tooth Lock

Toolbox Doors Hardware Bag

Item	Qty	Description
16	4	Bolt carriage 1/4-20x3/4
17	4	Nut 1/4-20 E-stop
18	2	Rubber Grommet 3/8 x 3/32
19	1	Round Flush-Mount Handle

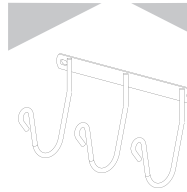

Multipurpose Utility Hooks

Zinc plated for long life, rounded for safety. 2" Hook Assembly
025527 Triple Hook Assembly
020136 Upright Mounted Single Hook
020137 Upright Hook turned 90 deg.
 utility hooks pg 9

Heavy Duty, vinyl coated "J" hooks

Can be mounted to shelving and verticle surfaces. Sold as set of two with hardware.
 large 5" diameter **027503**
 small 3" diameter **027502**

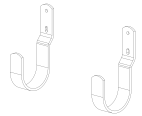

utility hooks pg 9

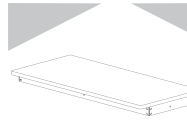

Worktops

Laminate covered plywood surface. Converts any low-profile module into a workbench top.
020316 027480
027497 021481

storage door pg 11

Lockable Storage Doors

May be added to any storage module to create a secure compartment.
027500 027495 027496
027497 027498 027499

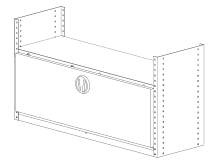

storage door pg 10

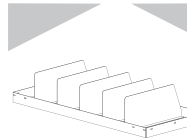

Shelf Dividers

Bolt to shelving, no drilling required. Easily adjustable. Sold as set of five dividers.

021396 021395 022528

fixed shelf divider pg 6

Key Machine Base

Holds up to two key cutting machines. Mounts to 18" deep worktop.

026087

key machine base pg 11

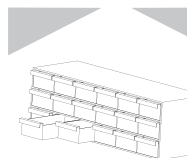
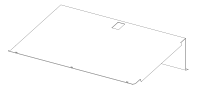

Drawer Parts Cabinets

Available in six sizes. Include drop-in drawer dividers and bolt to shelving. Tilt shelf recommended.

021021 021058 021056
021057 021007 021000

drawer parts cabinet pg 9

Drawer Cabinets

Lockable storage drawers include divided scoop tray. May be stacked or mounted to shelving module.

022788 027259 022787
025070 024515 024056

drawer cabinets pg 7

