

VENTED COMPRESSED GAS CABINETS

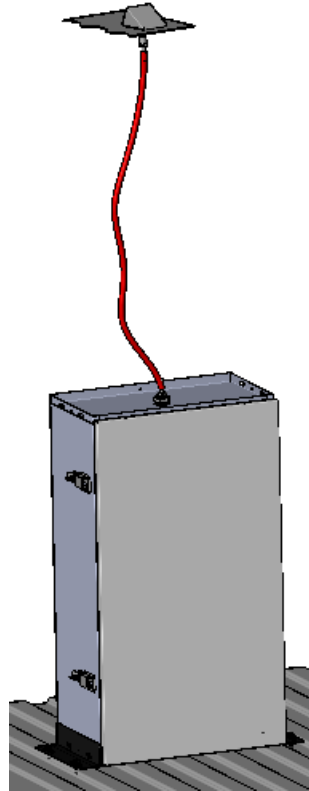

STOP **BEFORE DRILLING** **STOP**
CHECK ALL MOUNTING LOCATIONS TO PREVENT PENETRATING
GAS LINES, GAS TANKS, BRAKE LINES, WIRING OR ANY OTHER STRUCTURE OF VEHICLE

COMPONENTS / HARDWARE

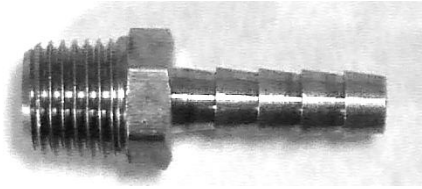

BARB FITTING

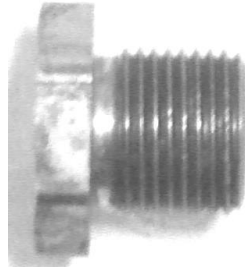

ADAPTER



NIPPLE



ADAPTER NUT

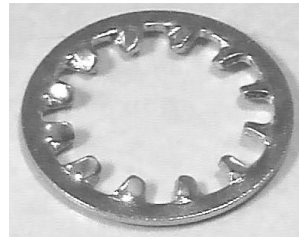

ADAPTER TOOTHED WASHER



AIR HOSE

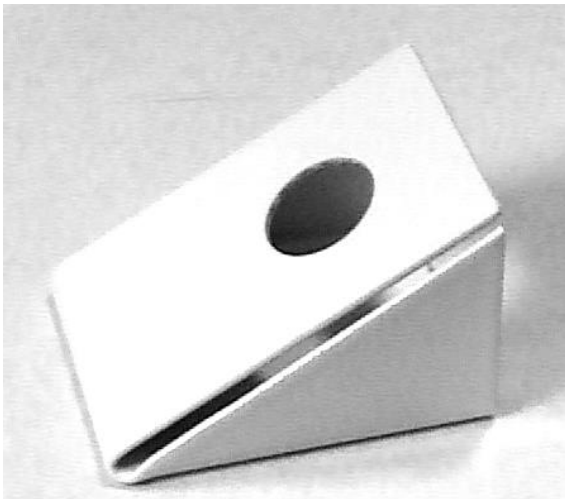

VENT COVER

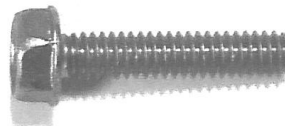

MACHINE SCREW



LOCK WASHER



PLUSNUT

NOTE: DOOR NOT SHOWN FOR CLARITY.
WIRE BASKET FOR SMALL CYLINDERS
PROVIDED ON INSIDE OF LARGE CABINET
DOOR ONLY

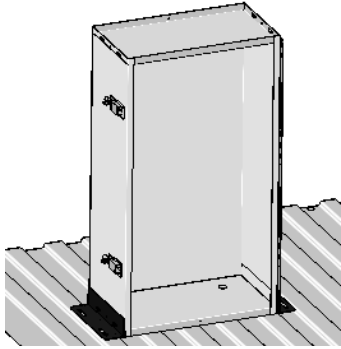

Position cabinet in desired location, and mark the mounting hole locations through the slots in the mounting flanges.

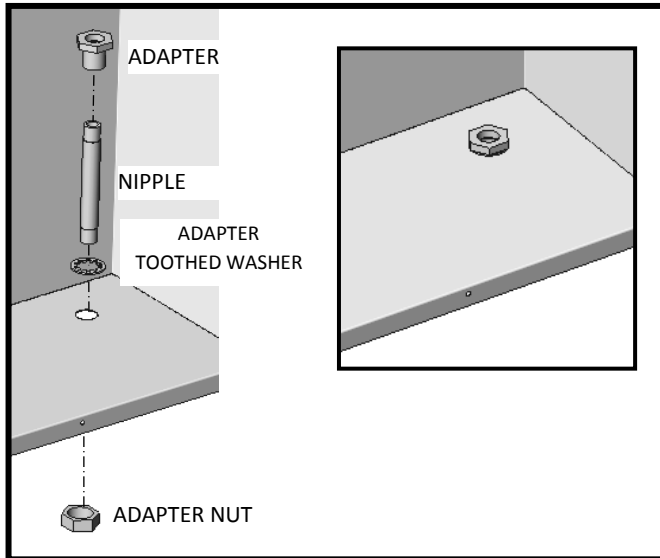
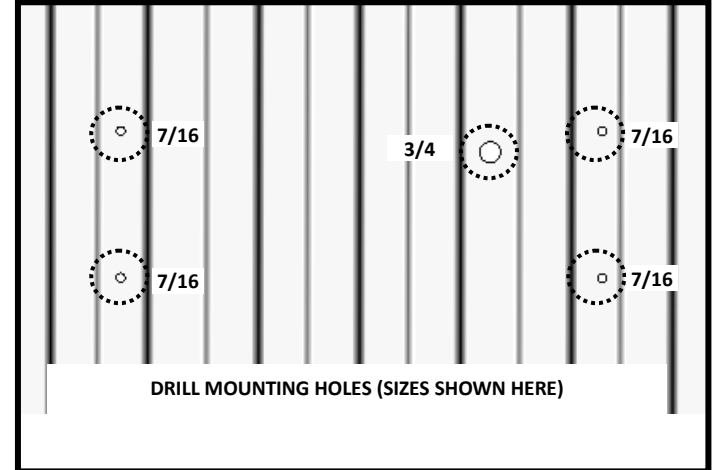
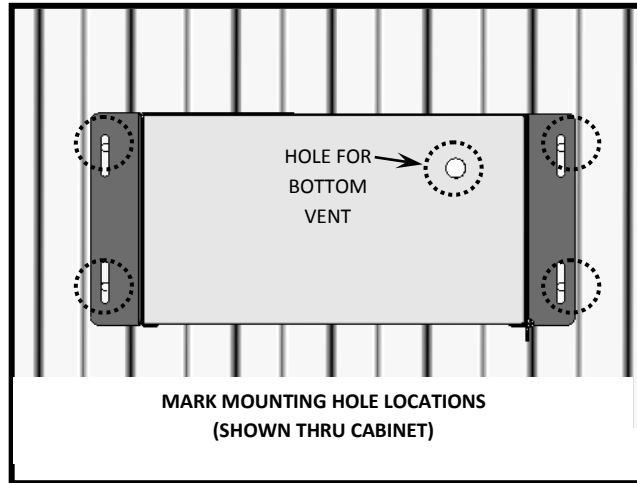

Insert bottom vent pipe through hole in cabinet floor as shown here.

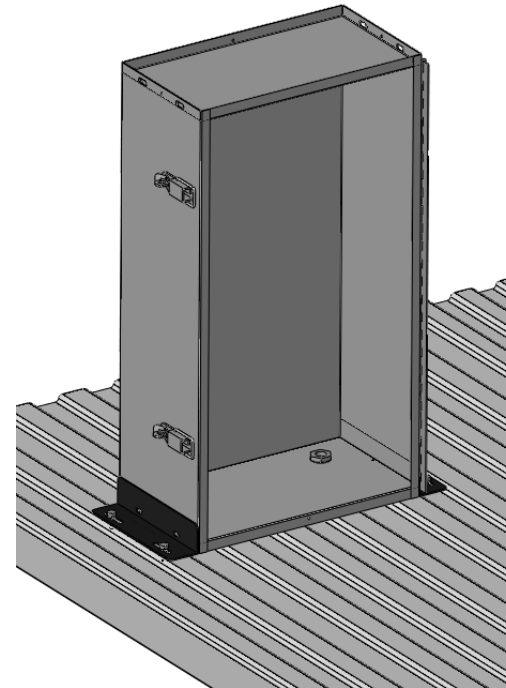

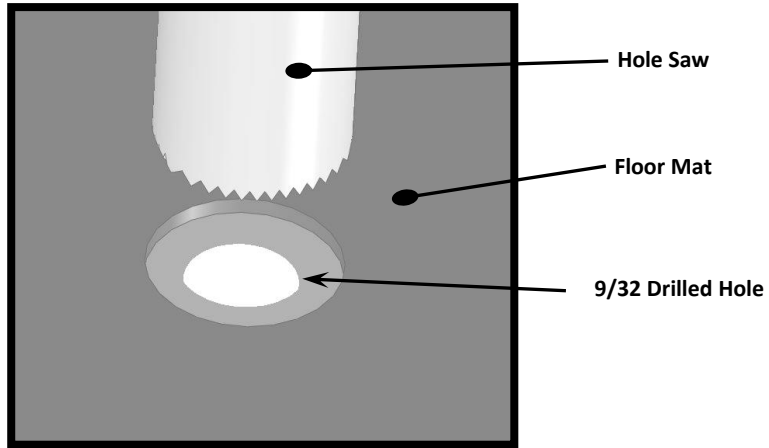

NOTE:

Using a 1-1/8" Hole Saw specially made for mat cutting, hole saw out all holes in the mat making sure to align hole saw with pre drilled holes. **Make sure not to drill through the metal floor of the van.** Once drilled clear out each area of excess debris

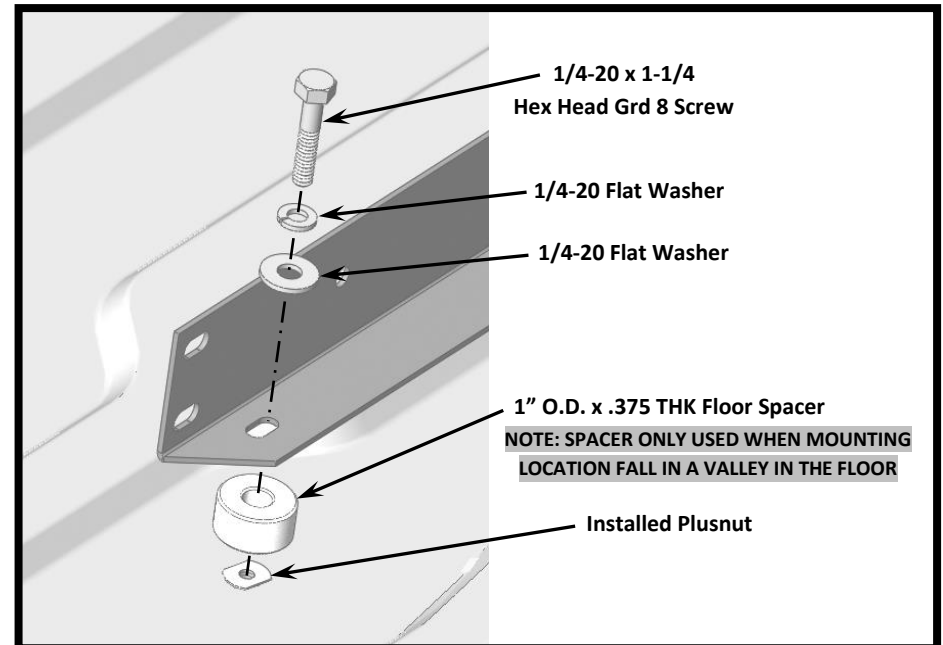
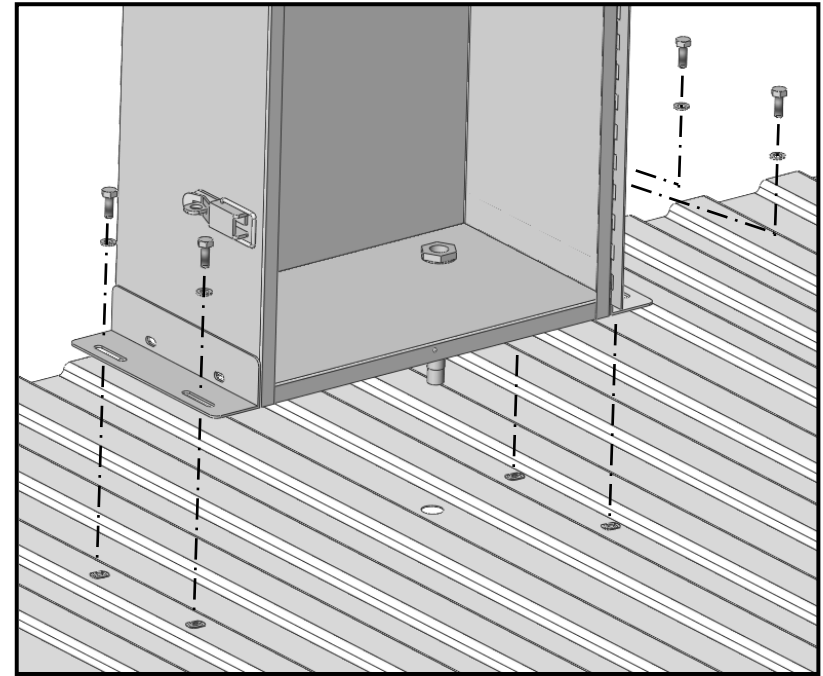

(SEE PAGE 5 FOR PLUSNUT INSTALLATION)



BEFORE DRILLING



**CHECK ALL MOUNTING LOCATIONS TO PREVENT PENETRATING
GAS LINES, GAS TANKS, BRAKE LINES, WIRING OR ANY OTHER STRUCTURE OF VEHICLE**

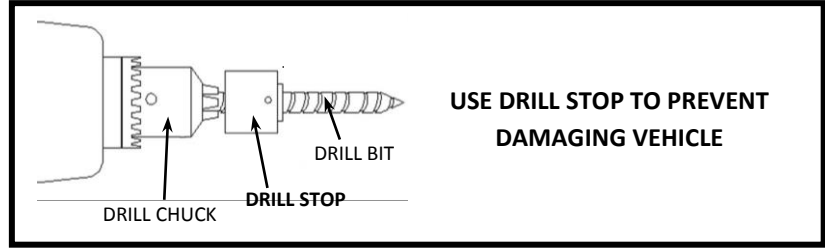

The Plusnut® is pre-bulbed for easy installation

1



The Plusnut® is pre-assembled with hex cap and hex bolt.
Then it is inserted into a pre-drilled hole

2

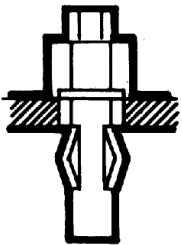

As the bolt is tightened, the Plusnut® upsets
and provides outstanding
blind fastening holding power

3

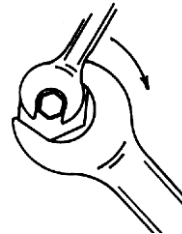

C-500 tool tightens bolt thru hex head cap into Plusnut® A
ratchet, open-end or closed –end wrench can be used.

4



Fully upset Plusnut® provides
a reliable nut plate for fastening.

5

CHECK EACH BOLT LOCATION
to ensure they are tightened to the specified
torque setting.



TORQUE SETTING:

Size – 1/4 GRD 5 = 7- 9.6 Ft.-Lbs.

Size – 1/4 GRD 8 = 10- 13.5 Ft.-Lbs.

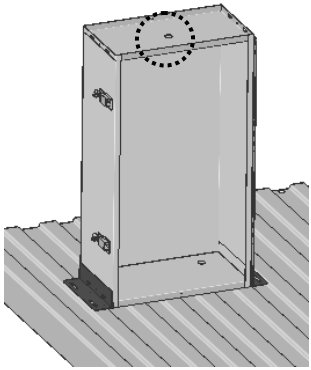

Drill a 3/4 hole in the top of cabinet to install top vent fitting.

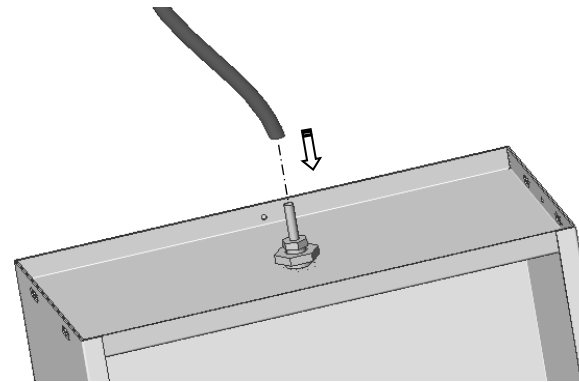
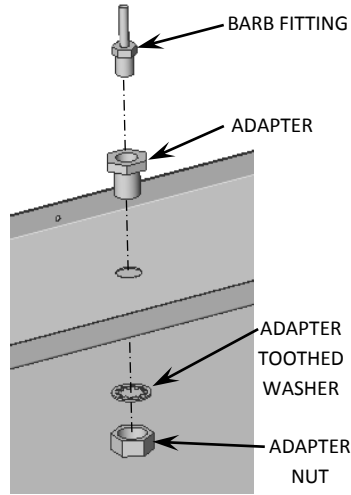

Slide Air Hose onto Barbed Fitting

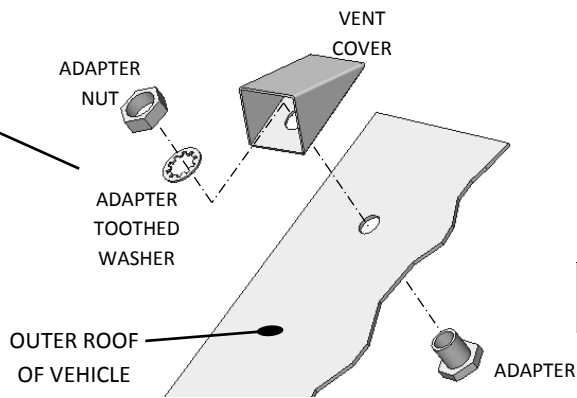
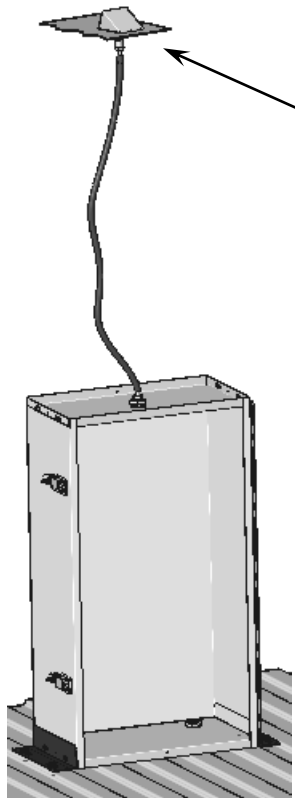

Drill a 3/4 hole in the roof of vehicle to install top vent fitting and vent cover as shown here.

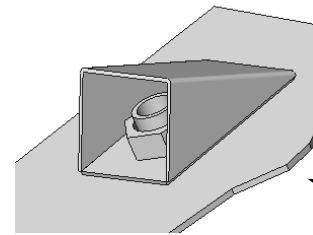

Screw into Adapter

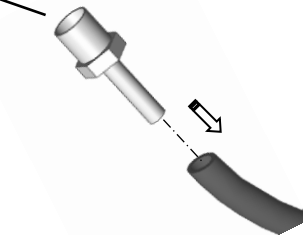

Slide Air Hose onto Barbed Fitting