

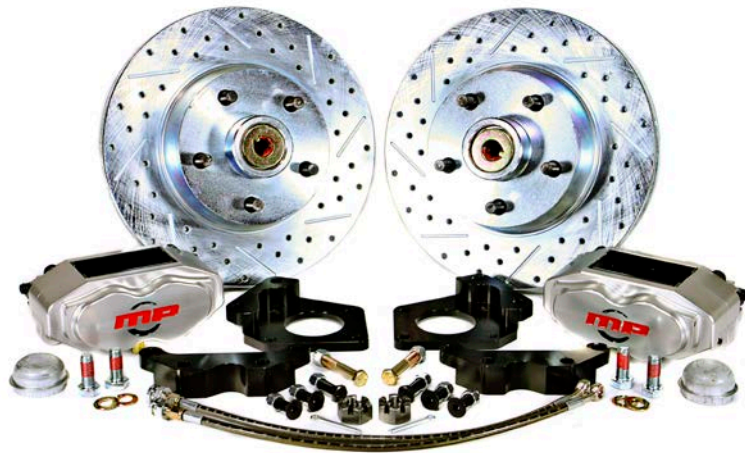

Master Power Brakes

Front Disc Brake Conversion Kit

1968-1969 & 1970-1973 Mustang w/OE Disc Brakes & Miscellaneous Ford Applications
P/N: DB2513B & DB2514B



Thanks for your purchase of our Rallye Series Disc Brake Conversion Kit for the 1968-1973 Ford Mustang and other Ford car applications. This system is a bolt-on application that should be able to be performed with simple hand tools. It is designed to work with your existing disc brake spindle and should not require removing the spindle from the vehicle. **NOTE:** We have seen this system used on some 14" wheels when using a wheel spacer (.250" thick) between the rotor and the wheels.

Installation Notes:

- Please read all instructions before attempting the installation.
- Proper operation of your brakes is essential for your safety and the safety of others. Any brake service should be performed by a professional technician experienced in the installation of brake systems.
- Any installation requiring you to remove a wheel or gain access under the vehicle requires use of jack stands appropriate to the weight of the vehicle. In all cases recommended ratings for jack stands should be at least 2-tons.
- All installations require proper safety procedures and protective eyewear.
- A selection of hand tools sufficient to engage in the installation of these products is assumed and is the responsibility of the installer to have in his/her possession prior to beginning this installation. All installations, which require removal of hydraulic hoses and/or bleeding of the brakes, require appropriate fitting/line wrenches, as well as a safety catch can and protective eyewear. Other than these items, if unique or special tools are required they are listed in the section for that step.
- **ALWAYS CONFIRM WHEEL FITMENT PRIOR TO BEGINNING THE INSTALLATION OF ANY "UPSIZED" BRAKE SYSTEM!!** Returns will not be accepted for ANY installed part or assembly. Use great care to prevent cosmetic damage when performing wheel fit check!
- Before starting the installation, verify that all parts are included with the brake kit. If items are missing, notify Master Power Brakes immediately.
- Master Power Brakes recommends the use of a high quality DOT 3 or DOT 4 brake fluid. **ALL WARRANTY IS VOID IF DOT 5 FLUID IS USED.**

Parts List	
Quantity	Description
2	Billet aluminum 4-piston calipers (Pads included)
1	LH 11" Rotor (Cross-drilled, Slotted, & Zinc-washed)
1	RH 11" Rotor (Cross-drilled, Slotted, & Zinc-washed)
1	LH Primary Caliper Mounting Bracket
1	RH Primary Caliper Mounting Bracket
1	LH Intermediate Caliper Mounting Bracket
1	RH Intermediate Caliper Mounting Bracket
2	A5 Outer Wheel Bearing (Pre-greased & Installed) – DB2513B Only
2	A6 Inner Wheel Bearing (Pre-greased & Installed)-DB2513B Only
2	A12 Outer Wheel Bearing (Pre-greased & Installed) – DB2514B Only
2	A13 Inner Wheel Bearing (Pre-greased & Installed)-DB2514B Only
2	6815 Inner Grease Seal (Installed in rotor)
2	Braided s/s brake hose (Includes 2-10mm Banjo bolts, 4-Crush washers, 2-3 AN x 3/8"-24 adapters)
2	9/16"-12 x 2-1/4" Grade 8 Hex Head Bolt
2	9/16" SAE Flatwasher
2	7/16"-14 x 1-1/4" Grade 8 Hex Head Bolt
2	7/16" SAE Flatwasher
4	M12 x 1.75 x 45mm Hex Head Bolt
4	M12 SAE Flatwasher
1	Shim Package
1	Syringe bleeder
1	30" Bleed hose
2	Vinyl brake line caps
2	Spindle Castle Nuts
2	Grease Caps
2	Cotter Pins

Installation:

1. With the vehicle properly supported, remove the front wheels and tires.
2. Disconnect the brake hose from the hardline at the frame using a line wrench. Cap the hardline with the supplied rubber caps to avoid fluid dripping. Remove the clip retaining the brake hose and disengage the hose from the bracket. Refer to Figure 1 below for reference.

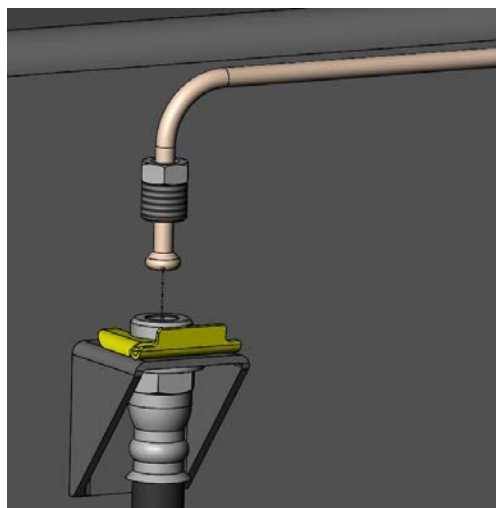

Figure 1 – Brake hose removal

3. Removing of the factory brake assembly is required next. Remove the drum and hub assembly along with the shoes, hardware and backing plate.
4. Before installing the disc brake kit, inspect the spindles for any excessive wear or damage. If any is present, replace the spindle(s) as necessary. If spindles are good, clean all attachment points along with the spindle pin to insure proper installation of the new components.
5. Install the primary caliper mounting bracket on the spindle using the 9/16"-12 x 2.1/4" Grade 8 Hex Head Bolt in the upper mounting hole and the 7/16"-14 x 1-1/4" Grade 8 Hex Head Bolt in the lower mounting hole (mounting hole is located on the steering arm portion of the spindle). **NOTE:** The brackets are left and right specific. The driver side bracket part number begins with 661 and the passenger side begins with 662. Once both bolts are in place, torque the upper bolt to 100 lb/ft and the lower to 65 lb/ft. See Figure 2 below for reference.



Figure 2 – Primary Caliper Bracket Installation (Driver Side Shown)

6. Install the intermediate caliper mounting bracket to the base bracket using the supplied M12-1.75 x 45mm Hex Head Bolts and washers. **NOTE:** Position the intermediate bracket to the base bracket with the step in the bracket facing outboard. See Figures 3a and 3b on the next page for reference. It is not necessary to torque the bolts at this point as these bolts may be removed at a later step when centering the caliper.



Figure 3a – Front View



Figure 3b – Rear View

7. With the brackets assembled on the spindle, slide the rotor onto the spindle. The new rotors come with premium bearings pre-installed and packed with Red Line Synthetic wheel bearing grease. **NOTE:** It is not necessary to add more grease. Apply a small amount of grease to the hub sealing surface and install the rotor assembly. Using the new castle nut along with the nut retainer, tighten the nut to 5-10 ft/lbs. Loosen the nut and tighten the nut again using the same 5-10 ft/lbs. Do this a couple of times spinning the rotor to fully seat the wheel bearings onto the spindle. Loosen the nut a final time and re-tighten to remove all play. Tighten approximately an additional $1/16^{\text{th}}$ of a turn to give the appropriate pre-load and line up the cotter pin hole. Install the cotter pin and dust cap. See Figure 4 below for correct placement of left and right rotors and Figure 5 on the next page for additional information on the rotor installation.

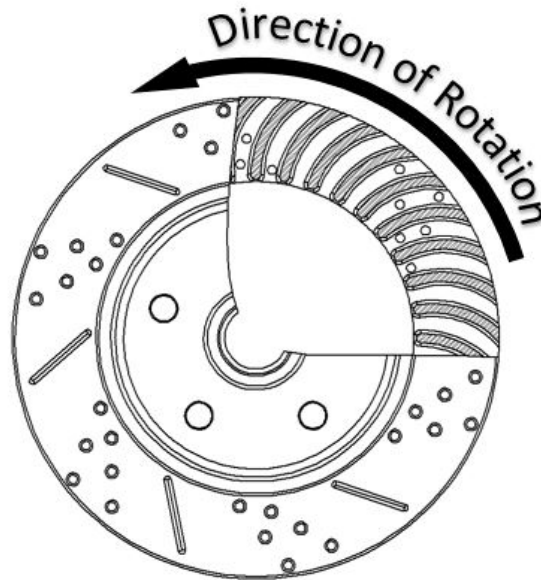

Figure 4 – Direction of Rotor Rotation

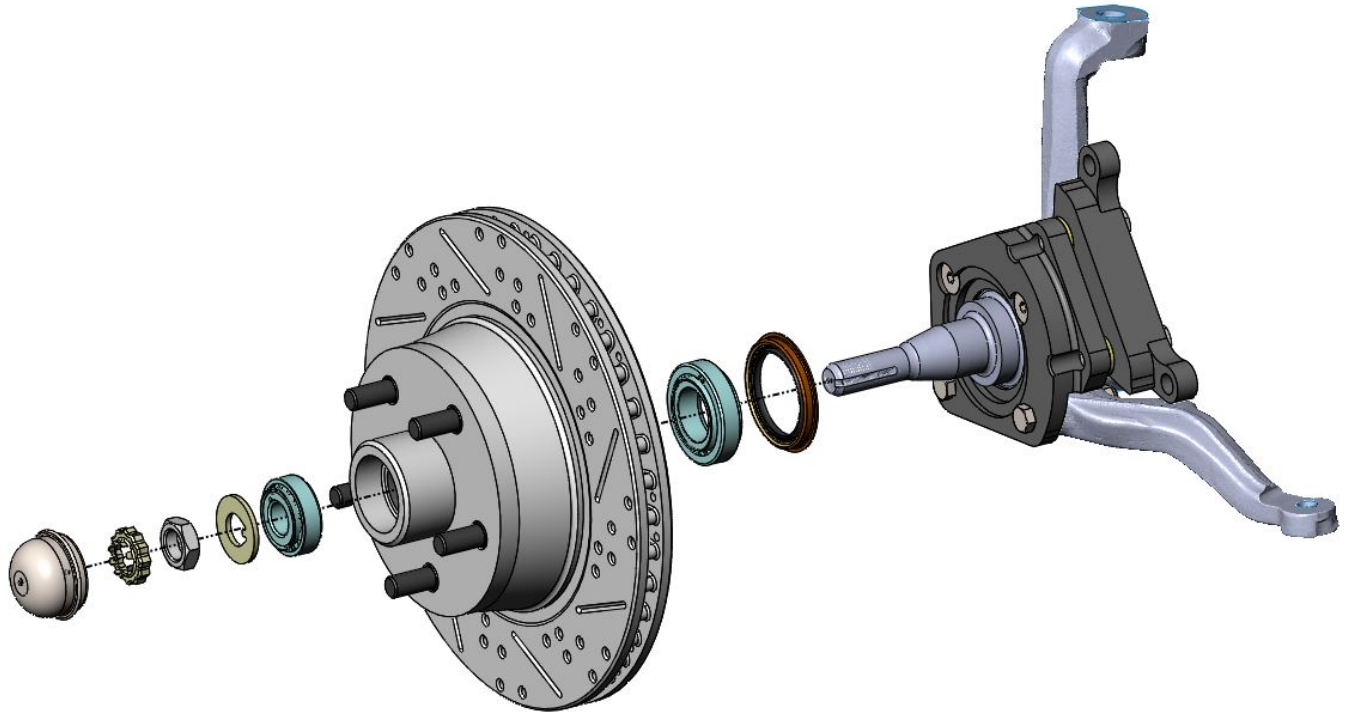

Figure 5 – Rotor Installation (Spindle not correct for application. Shown for reference only.)

8. With the pads removed from the caliper, position the caliper over the brake rotor and secure using the supplied M12 x 30mm Hex Head Bolts. Snug the bolts only at this time as they may need to be removed at a later step.
9. After installing the caliper, it is necessary to center the caliper over the rotor. A shim kit is supplied with the disc brake kit to accomplish this. Measure the gap from the rotor to caliper body at 4 points (top inside and outside and the bottom inside and outside). With all measurements taken, subtract the top inside measurement from the top outside measurement. Take that difference and divide by two to determine the shim required. For example, the inside measurement is .865" and the outside measurement is .905" leaving a difference of .040". Divide the difference by two leaving the necessary shim at .020". Do this procedure at both the top and bottom to determine appropriate shimming. It is possible for the top and bottom to require different thickness shims. Set the gaps to within .005" of each other. This will keep the possibility of noise to a minimum. Follow the steps below for proper shimming of the calipers once the measurements have been taken:
 - a. Select the required shims from the shim kit provided.
 - b. Remove the caliper.
 - c. Loosen the bolts from between the primary and intermediate brackets.
 - d. Install the appropriate shims removing one bolt at a time. Snug bolts at this time.
 - e. Reinstall the caliper and recheck the gap as described above. If necessary, add or remove shims.
 - f. Once proper caliper location has been achieved through shimming, remove the caliper and torque the bolts between the brackets to 80 ft/lbs.
 - g. Reinstall the caliper with pads and torque the caliper mounting bolts to 80 ft/lbs.

NOTE: Shimming of the caliper is required due to variations in spindle manufacturing and wear at the bearing seat area of the inner bearing. Refer to Figure 6a for measuring reference and Figure 6b on the location of the shims.

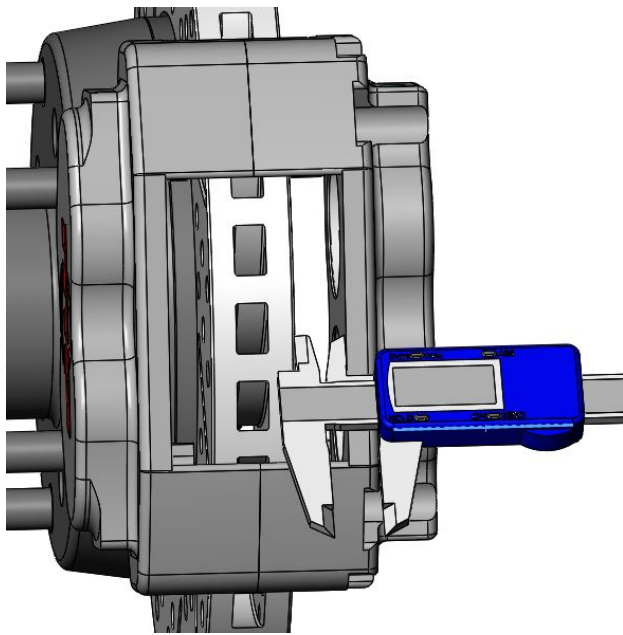

Figure 6a – Measuring the Pad to Rotor Clearance

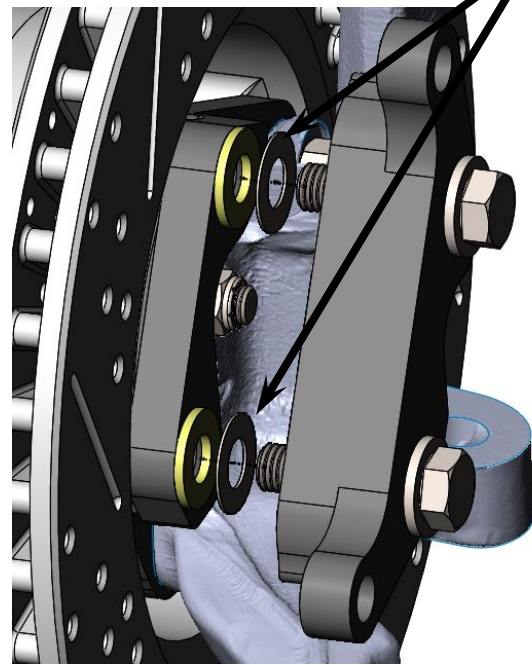

Figure 6b - Shim Location

10. Install the stainless steel braided hose using one copper washer on each side of the banjo fitting. Connect the hose to the hardline and install the hose lock. **IMPORTANT:** Position the hose to avoid interference with the wheel and suspension components through the entire range of motion. Torque the banjo bolt to 15-20 ft/lbs.
11. Repeat these steps for the other side and recheck all attachment points and fittings.
12. Once the master cylinder has been properly bench bled and then installed on the vehicle, the remaining brake system can be bled to remove all of the air from the system. **REMEMBER:** Master Power Brakes requires the use of either DOT 3 or DOT 4 brake fluid and recommends the use of Pentosin Super Dot 4 fluid as seen on the next page in Figure 8. Any warranty is void if DOT 5 fluid is used.



Figure 8 – Pentosin Super DOT 4

13. The installation is now complete