



Master Power Brakes Universal Emergency Brake Cable Kit Various Legend Series Applications p/n: HWC2500



Thanks for the purchase of the Master Power Brakes Universal Emergency Brake Cable Kit. This kit is designed as a universal system and will work with our rear disc brake conversion kits. The cables included in the kit are designed as a cut-to-fit and will therefore fit many vehicles and applications. It is strongly recommended that the instructions be read completely before starting. As with anything that is universal, ***measure twice and cut once.***

Installation Notes:

- Please read all instructions before attempting the installation.
- Proper operation of your brakes is essential for your safety and the safety of others. Any brake service should be performed by a professional technician experienced in the installation of brake systems.
- Any installation requiring you to remove a wheel or gain access under the vehicle requires use of jack stands or a lift appropriate to the weight of the vehicle. In all cases, recommended ratings for jack stands should be at least 2-tons. If using a floor jack, be sure to use the appropriate wheel chocks.
- All installations require proper safety procedures and protective eyewear.
- A selection of hand tools sufficient to engage in the installation of these products is assumed and is the responsibility of the installer to have in his/her possession prior to beginning this installation. All installations, which require removal of hydraulic hoses and/or bleeding of the brakes, require appropriate fitting/line wrenches, as well as a safety catch can and protective eyewear. Other than these items, if unique or special tools are required they are listed in the section for that step.
- Before starting the installation, verify that all parts are included with the brake kit. If items are missing, notify Master Power Brakes immediately.

Body End of Park Brake Cable (Below)

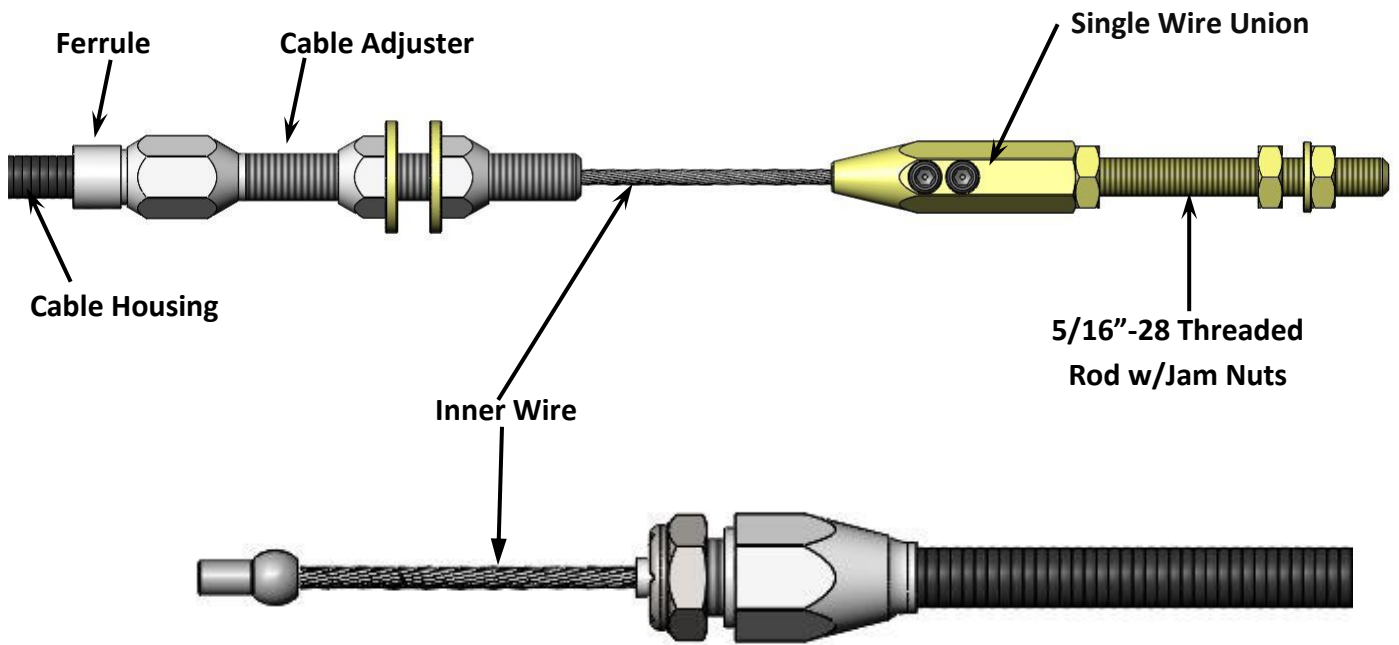

Caliper End of Park Brake Cable (Above)

1. With the rear disc brake conversion kit completely installed, remove the inner wire from the outer cable housing.
2. Insert the threaded end of the cable into the bracket on the rear caliper. **NOTE:** Due to inconsistency in the caliper cable brackets, it may be necessary to enlarge the hole in the bracket slightly. This will allow the aluminum nut to set flush with the bracket. Install the provided nut. It is not necessary to tighten completely at this point. See Figure 1 below for reference.

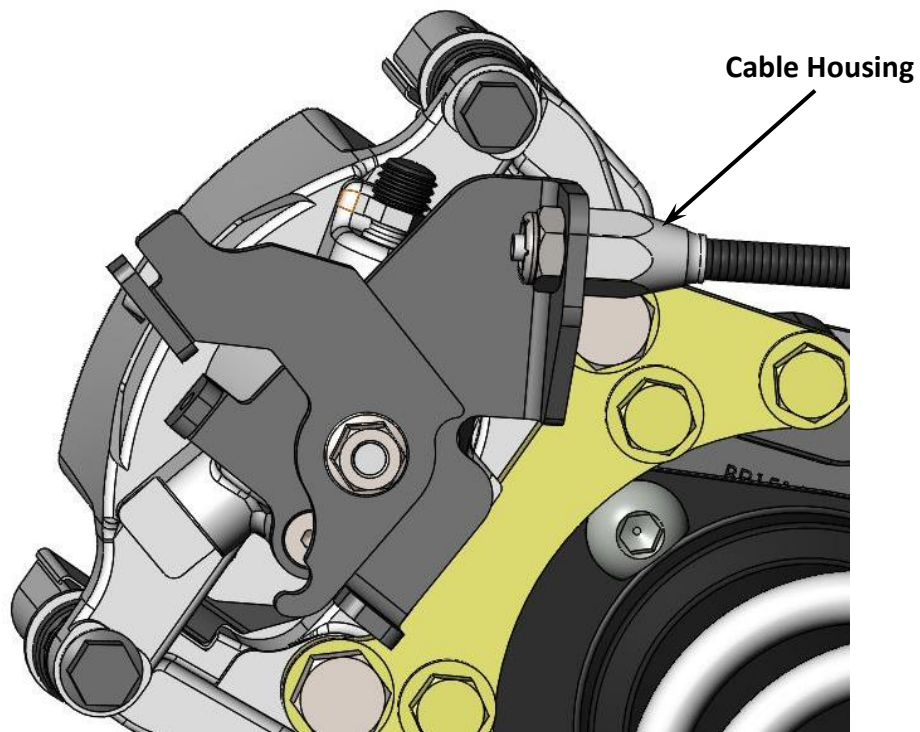

Figure 1 – Cable Attachment

3. Route the black housing through the rear suspension making sure the suspension does not come in contact with the cables. Using the cable adjuster and the ferrule, determine the ending location of the housing. This can be at a factory cable mounting point or through a fabricated bracket of your choice. **REMEMBER:** Allow enough room for the universal cable attaching components to have enough room on the side opposite the cable housing.
4. Once the proper housing length has been determined, it will be necessary to shorten the cable housing. **IMPORTANT: Make sure the inner wire is removed from the cable housing.** Remove the aluminum ferrule from the housing along with the cable adjuster. Cut the cable housing at your mark using heavy duty diagonal cutters (Klein brand, p/n: D2000-28) or using a hacksaw. After cutting the cable housing, slide the ferrule back onto the housing. The ferrule does not require crimping or otherwise when installed on the cable housing.
5. If the cable was removed from the vehicle to cut, reinstall the cable into the caliper (as done previously in Step 2) and place the cable adjuster into the factory attaching point or the fabricated bracket. Snug the nuts at this point as this may be used later for final adjustment. Refer to Figure 2 below for reference.

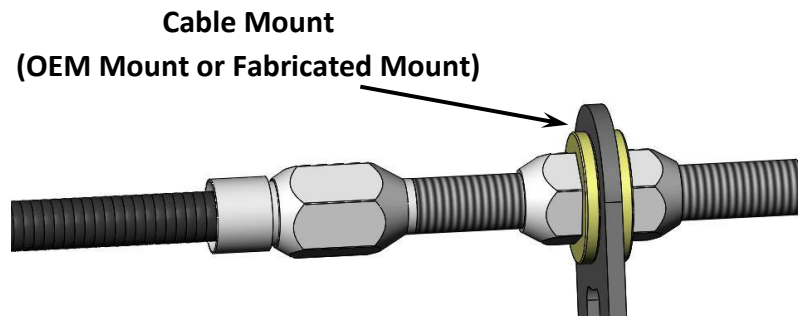

Figure 2 – Cable Attaching Point

6. Once reinstalled, insert the inner wire through the park brake lever and guide the inner wire through the cable housing as show in Figure 3 below.

Inner Wire

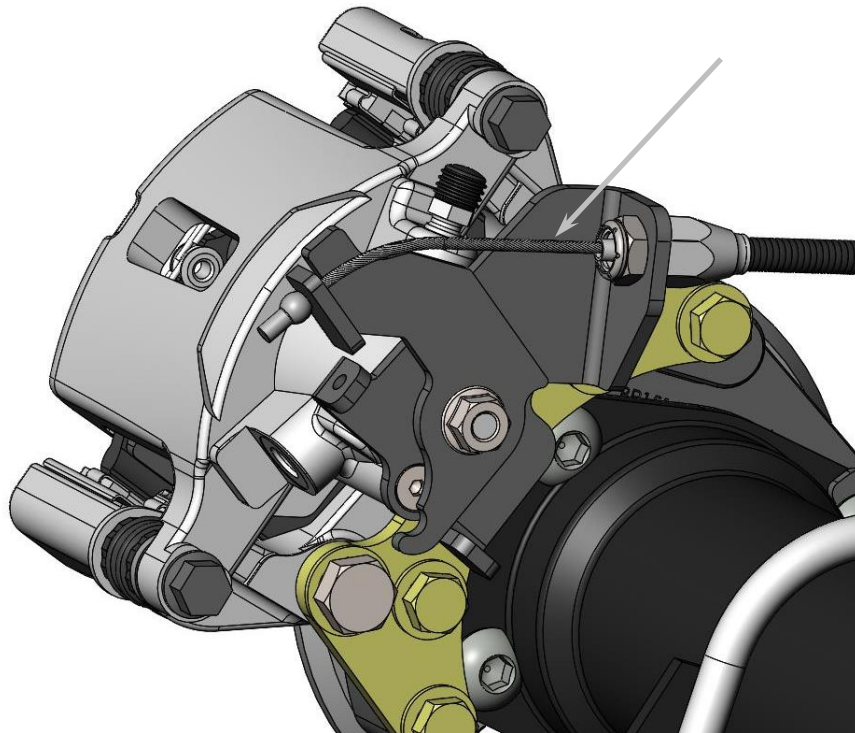

Figure 3 - Inner Wire Being Installed

7. With the inner wire extending past the cable adjuster, mark the wire to be cut. The wire will need at least 3.000" of total wire travel to allow for adequate movement of the park brake lever at the caliper. Refer to Figure 4 below for reference. **REMEMBER: Allow an additional 1.375" of wire length for insertion into the single wire union.**

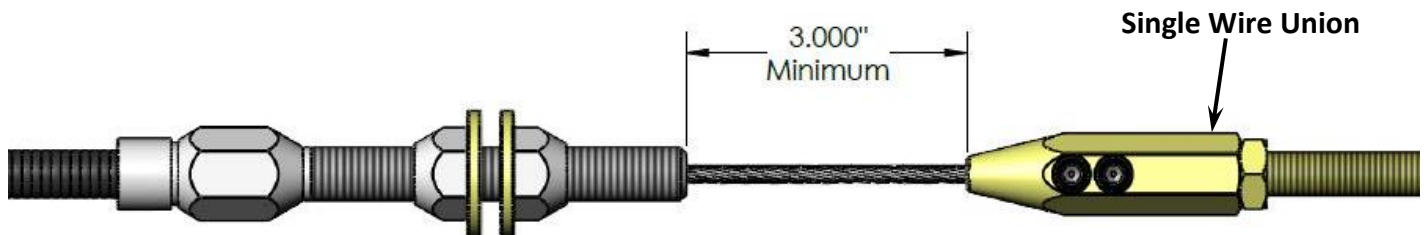

Figure 4 - Inner Wire Minimum Clearance Length

8. Once marked, the inner wire can be removed from the cable housing to be cut. The inner wire can be cut with a hacksaw, heavy duty diagonal cutters or with a cut-off wheel. Once cut, re-install the inner wire into the cable housing as done in Step 6.
9. Place the single wire union assembly over the end of the wire and tighten the set screws with a 1/8" Allen wrench. The threaded rod that inserts into the wire union assembly may be shortened to allow for adjustment. Using the provided jam nut, tighten the threaded stud into the union along with the connector if used. If needed, use the provided connectors to attach to the factory cables. Refer to Figure 5 below for reference on using the provided connectors.

**Factory Park
Brake Cable**

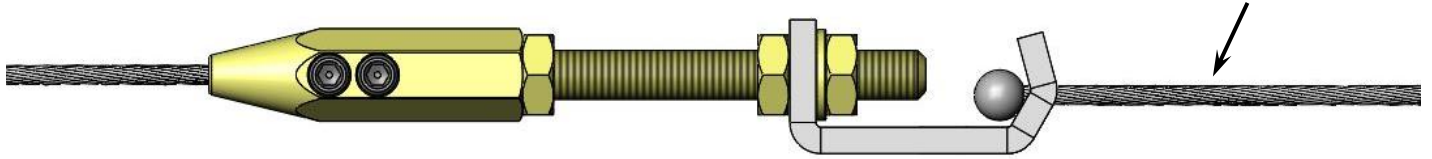

Figure 5 – Attachment to Factory Park Brake Cables w/ Provided Connectors

10. Adjust all cables as necessary to remove any slack and to allow for proper operation of the emergency brake system.