



Master Power Brakes
Power Booster Conversion Kit
67-70 Ford Mustang
P/N: BM15214-1 & 2



BM15214-1 (9" Single w/Automatic Trans)

Thanks for your purchase of our Power Brake Conversion Kit for the 67-70 Ford Mustang applications. This is a simple installation requiring very minimal vehicle modification. Once installed, you will experience that nice easy to operate power pedal that you are looking for. The system does require an engine making 18" of vacuum and is designed to work with either disc/drum or disc/disc. If using 4-wheel drums, give us a call to make sure this system will still work for your vehicle.

Installation Notes:

- Please read all instructions before attempting the installation.
- Proper operation of your brakes is essential for your safety and the safety of others. Any brake service should be performed by a professional technician experienced in the installation of brake systems.
- Any installation requiring you to remove a wheel or gain access under the vehicle requires use of jack stands or a lift appropriate to the weight of the vehicle. In all cases, recommended ratings for jack stands should be at least 2-tons. If using a floor jack, be sure to use the appropriate wheel chocks.
- All installations require proper safety procedures and protective eyewear.
- A selection of hand tools sufficient to engage in the installation of these products is assumed and is the responsibility of the installer to have in his/her possession prior to beginning this installation. All installations, which require removal of hydraulic hoses and/or bleeding of the brakes, require appropriate fitting/line wrenches, as well as a safety catch can and protective eyewear. Other than these items, if unique or special tools are required they are listed in the section for that step.
- **ALWAYS CONFIRM WHEEL FITMENT PRIOR TO BEGINNING THE INSTALLATION OF ANY BRAKE SYSTEM!!**Returns will not be accepted for ANY installed part or assembly. Use great care to prevent cosmetic damage when performing wheel fit check!
- Before starting the installation, verify that all parts are included with the brake kit. If items are missing, notify Master Power Brakes immediately.
- Master Power Brakes requires the use of a high quality DOT 3 or DOT 4 brake fluid. Synthetic DOT 4 fluids are acceptable. **ALL WARRANTY IS VOID IF SILICONE DOT 5 FLUID IS USED.**

Parts List	
Quantity	Description
1	8" Dual Diaphragm Booster (BM15214-1 & 2)
1	1" Dual Reservoir Master Cylinder (BM15214-1)
1	1-1/8" Dual Reservoir Master Cylinder (BM15214-2)
1	Brake Pedal Assembly PA1521SK – Manual Trans (Used w/BM15214-1 & 2) (Includes: Pedal, Pedal Pad & Trim, Upper Mounting Bolt w/Bushings and Pushrod Bushings & Hardware)
1	Firewall Mounting Gasket
5	M8 – 1.25 Hex Head Flange Nut
2	M10 – 1.5 Hex Head Flange Nut
1	Vacuum Hose Kit (Includes: 2' Vacuum Hose, 1/2" x 3/8" NPT Bushing, 3/8" NPT 90° Fitting, Syringe Bleeder, 1/2"-20 Plug, & 9/16"-18 Plug)

Installation:

1. To begin the installation, remove all existing components from the firewall. This would include master cylinder, brake pedal push rod and switch and existing brake pedal. The firewall area should look like Figure 1 below prior to installation.



Figure 1 – Firewall Ready to Start Installation

2. Once everything is removed from the firewall, it is necessary to modify the firewall slightly for proper fitment of the brake booster. The necessary modifications are listed below and can be seen in Figure 2 below for reference:
 - a. The center hole will need to be elongated upward. The hole is enlarged from the current size to a size of $2 \frac{9}{16}$ " vertically and 2" wide. **IMPORTANT:** The end result is a hole that more resembles an oval.
 - b. The nuts in the pedal support will require drilling out to allow studs to pass through. Do not remove the nuts. Using a $\frac{5}{16}$ " drill bit, drill through the factory nuts in the underdash column support.
 - c. Drill a mounting hole using a $\frac{5}{16}$ " drill bit below the main center hole. This hole may already be in the firewall. If so, enlarge hole to the proper size. If the hole is not present, there will be an impression or dimple in the firewall where the hole will go.

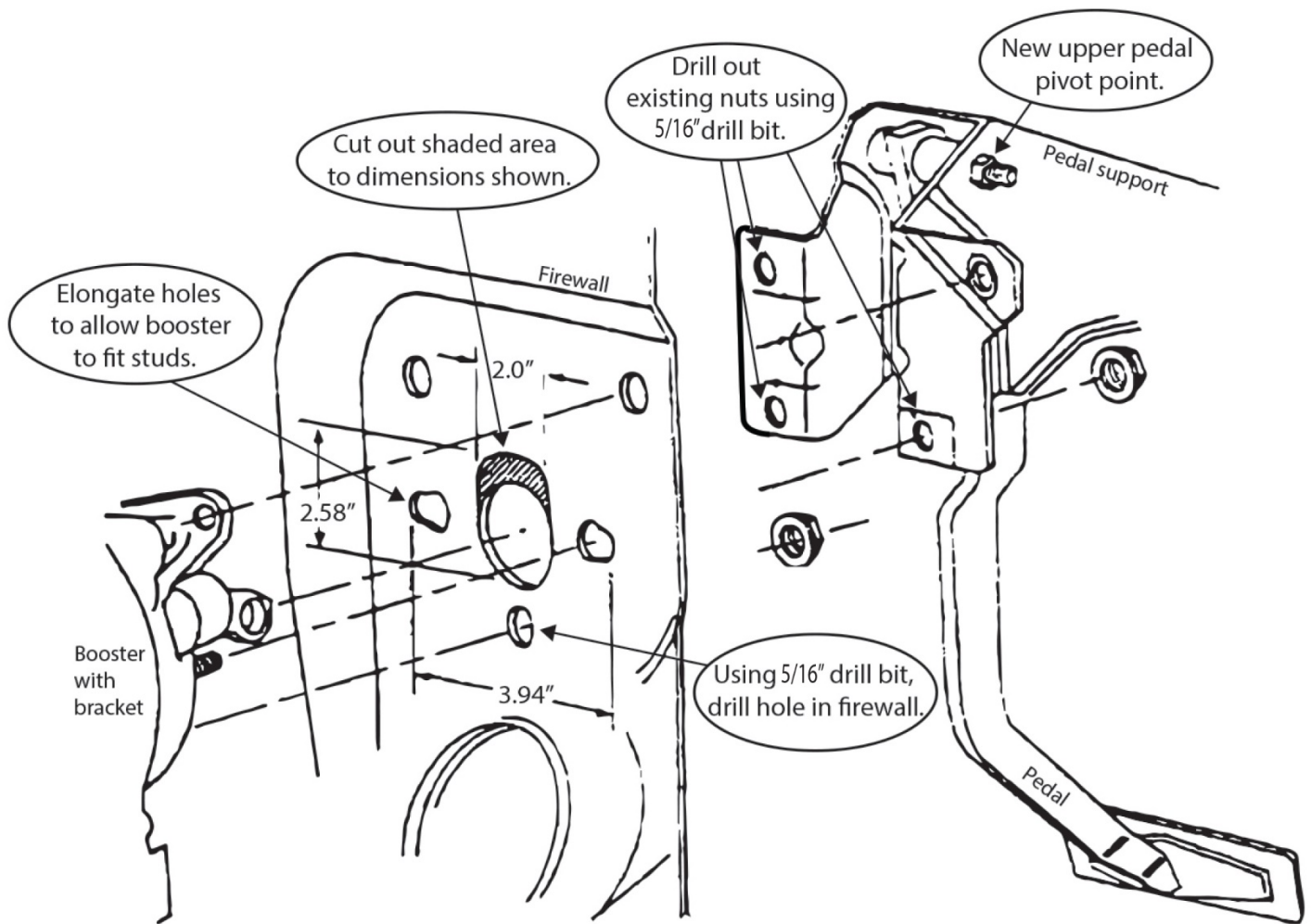

Figure 2 – Installation Drawing Showing Necessary Modifications

3. Once all of the firewall modifications are complete, it is necessary to locate the pedal mounting hole in the underdash column support. Most cars will have a 3/8" hole on the top of the support towards the front of the vehicle. If the hole is not present, removal of the column support will be necessary to drill the hole. There is a dimple in the column support to show where to drill. Figure 3 below shows a column support before the hole has been drilled and where it will be located. Reinstall the column support under the dash when complete. **Note:** Refer to the provided template on Page 7 for location of new pedal pivot hole if your OEM pedal box does not have a dimple or existing hole.

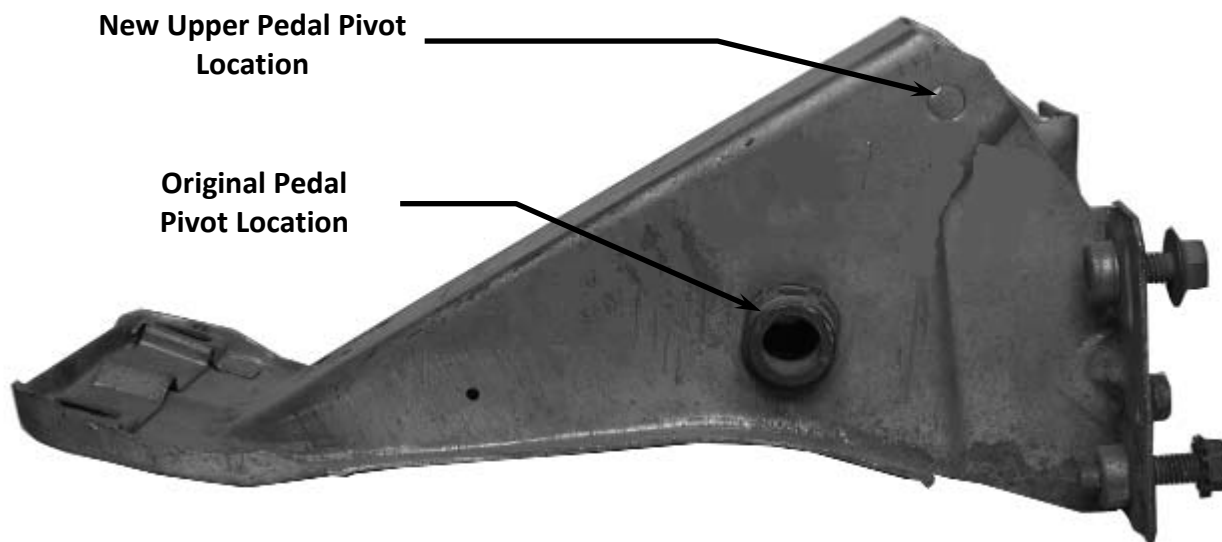

Figure 3 – Column Support Showing New Pedal Location

4. Test fit the booster assembly to the firewall to verify proper clearance between the engine along with any support braces or other accessories within the engine compartment. **NOTE:** Due to manufacturing inconsistencies along with various options for product placement, minor modifications or relocating of components may be necessary.
5. The booster and master cylinder can now be removed from the vehicle and prepared for bench bleeding of the master cylinder. To bench bleed the master cylinder, you have two options listed below:

Syringe Bleeding (Tools provided in system)

1. Position the master cylinder in a vise clamped by a mounting ear.
2. Pour brake fluid into each chamber of the master cylinder to between ¼ and ½ full.
3. Using the syringe with the rubber tip attached, fill the syringe using the fluid in the master cylinder chamber. Fill the syringe to about half full.
4. Press the rubber tip to the port on the master cylinder. Holding the syringe firm against the master cylinder, inject the fluid into the master cylinder. The fluid as it flows into the master cylinder will turn from bubbles in the chamber to a steady stream of fluid.
5. When pulling the syringe away from the master cylinder, fluid will drip from the port so have a damp towel handy to wipe off the master cylinder especially if you have painted it.
6. Plug the port with the provided plastic plugs from the Vacuum Hose Kit included with the system.
7. Once a steady stream has been detected, empty the syringe of fluid and then repeat steps 3 through 6 from above for the remaining port.

Hose Bleeding (Tools not provided in system)

1. Position the master cylinder in a vise clamped by a mounting ear.
 2. Pour brake fluid into each chamber of the master cylinder to between $\frac{1}{4}$ and $\frac{1}{2}$ full.
 3. Thread the plastic fittings into each port on the master cylinder and attach the hoses to the fittings. Route the hoses into the chambers on the master cylinder and secure. Make sure the hoses are submerged into the fluid.
 4. Using a large Phillips screwdriver inserted into the end of the master cylinder piston, press the piston slowly into the master cylinder and release. Repeat until there is no air coming from the hoses.
 5. Remove the hoses and fittings from the master cylinder. When removing the fittings from the master cylinder, fluid will drip from the port so have a damp towel handy to wipe off the master cylinder especially if you have painted it.
 6. Plug each port with the provided plugs from the Vacuum Hose Kit included with the system.
6. Install the booster/master combo on the firewall and install the provided M8 – 1.25 Hex Head Flange Nuts on the booster from under the dash. Leave loose and install the existing bolt into the firewall through the booster mounting bracket. Once installed, tighten all mounting hardware.
 7. Using the provided fittings, install the vacuum tee in the engine. The best source for obtaining vacuum from the engine is to install the fitting in an intake runner in the intake manifold. **NOTE:** The provided fitting is a $\frac{3}{8}$ "-NPT fitting. For proper operation, find a location that does not require adapting to a smaller fitting and thread size if possible. Connect the provided hose from the fitting to the check valve on the booster.

IMPORTANT: For proper operation of the brake booster, the engine must produce 18" of vacuum. Anything under 18" vacuum will produce a firm pedal.

8. Install the new pedal into the underdash column support using the provided bolt and bushings. **NOTE:** It is recommended that the bushings be greased with white lithium grease before installing. Torque the bolt and nut to 60 ft/lbs.
9. Position the booster pushrod onto the brake pedal using the provided bushing. When installing the pushrod and using the factory brake lamp switch, install everything as an assembly onto the pedal. **IMPORTANT:** Due to manufacturing variations, it may be necessary to grind a small amount of material from the back side of the pushrod if the operation of the system will not allow the brake lamps to turn off. See Figures 4, 5 and 6 below for installation photos.



Figure 4



Figure 5



Figure 6

10. With the entire booster/master combo installed, the master cylinder can be plumbed into the vehicle. Figure 7 and 8 below shows proper front and rear hookups for the brake lines.

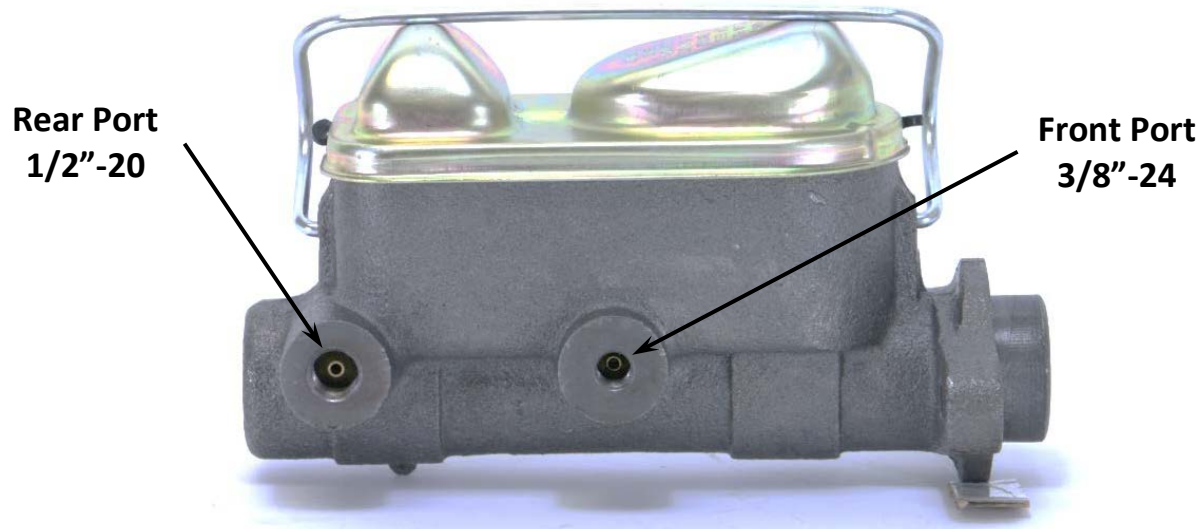

Figure 7 – Brake Line Routing (1" Bore Master Cylinder)

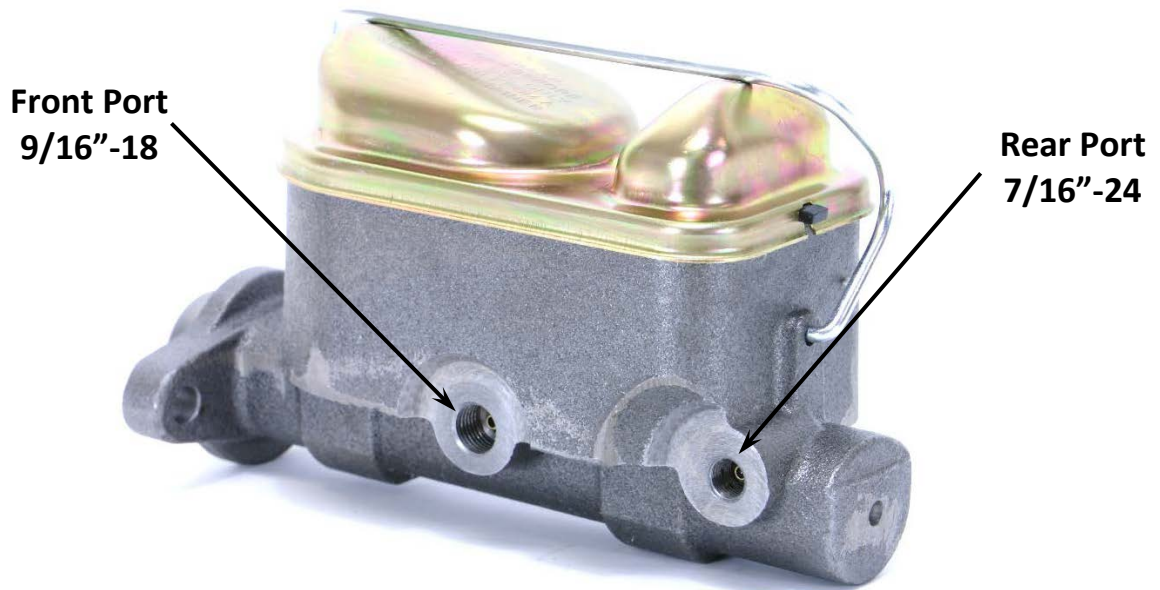
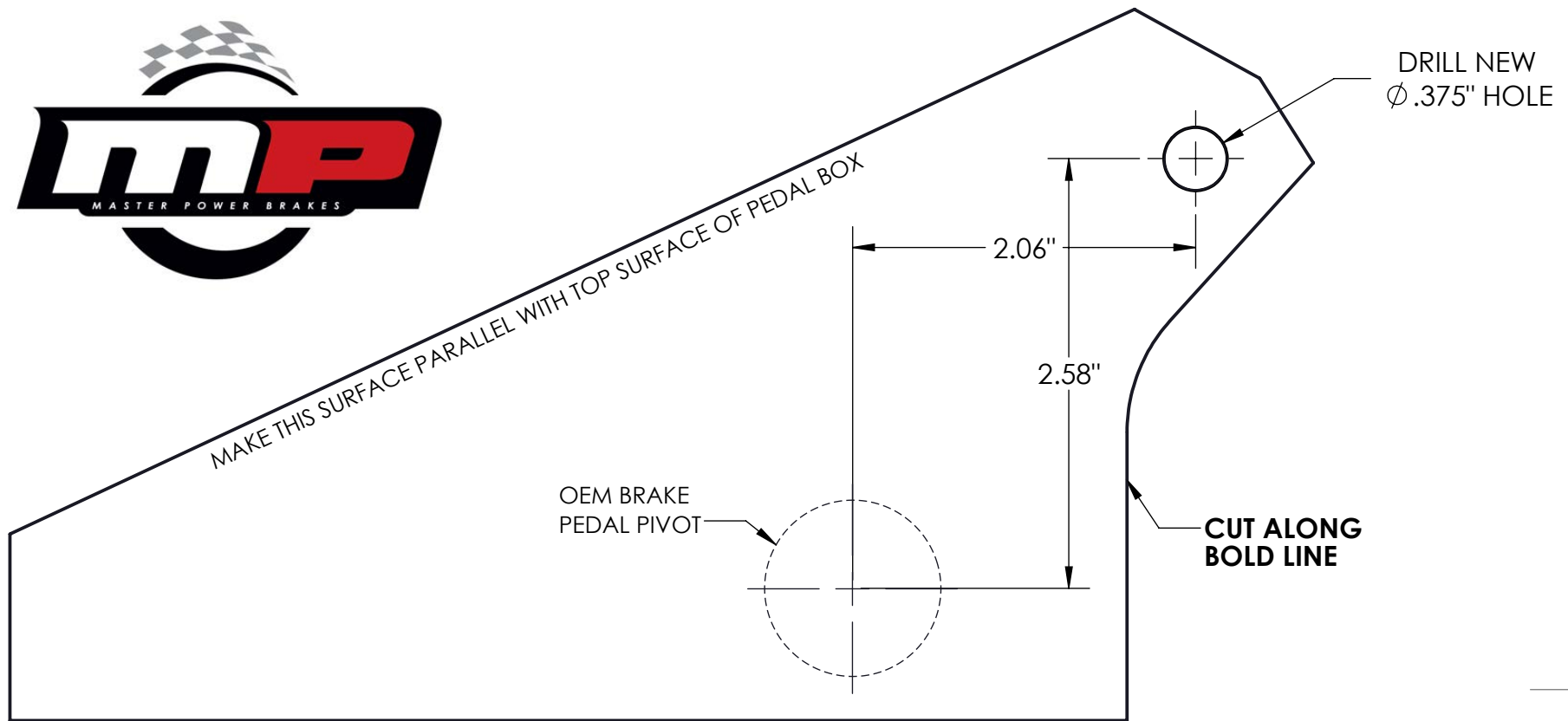

Figure 8 – Brake Line Routing (1-1/8" Bore Master Cylinder)

11. Bleed the brake system and the installation is now complete.



INSTRUCTIONS:

1. VERIFY THAT THE TEMPLATE IS TO SCALE BY MEASURING THE PRINTED RULER, IT SHOULD BE A 1:1 SCALE.
2. CUTTING ALONG THE BOLD LINE, CUT THE TEMPLATE.
3. USING SCISSORS OR A RAZORBLADE CUT OUT THE DASHED HOLE (OEM BRAKE PEDAL PIVOT).
4. PLACE THE TEMPLATE ON THE SIDE OF THE OEM PEDAL BOX, LOCATING IT OVER THE OEM BRAKE PEDAL PIVOT, MAKING SURE THE TOP SURFACE OF THE TEMPLATE IS PARALLEL WITH THE TOP SURFACE OF THE OEM PEDAL BOX.
5. USE CENTERPUNCH AND MARK THE LOCATION OF THE NEW ϕ .375" PEDAL PIVOT HOLE.
6. DRILL NEW PEDAL PIVOT HOLE.

Use provided ruler to verify template has printed to scale

