

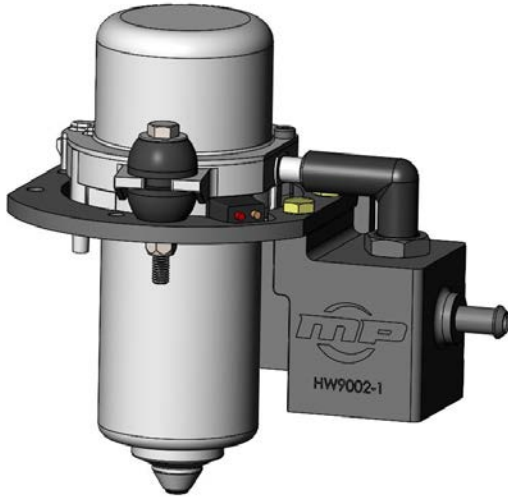

**Master Power Brakes
Electric Vacuum Pump Kit
Various Applications
P/N: AC9001K**

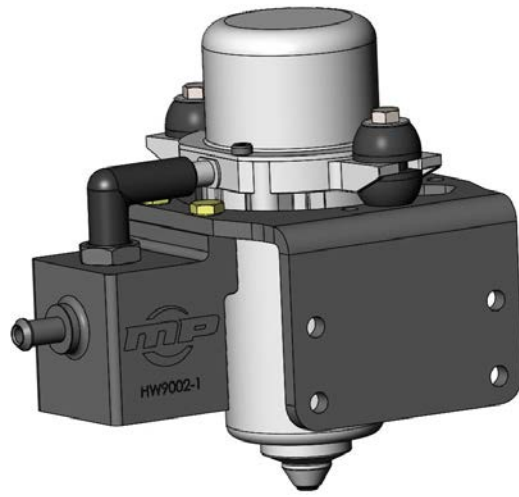

Front



Back

Thank you for purchasing the Master Power Brakes Electric Vacuum Pump Kit. If you are running a radical cam and therefore down on engine vacuum but still looking for the feeling in your brake pedal that a vacuum booster will provide, then you have made the right choice. The drawback to a vacuum pump has always been the noise. With the Master Power Brakes Silent Drive Vacuum Pump, that is no longer a problem.

| Parts List | |
|------------|--|
| Quantity | Description |
| 1 | Electric Vacuum Pump Assembly Includes: ○ Mounting Bracket ○ Vacuum Pump Control Module |
| 1 | Primary Power Wiring Harness |
| 1 | Switched Power Wiring Harness |
| 10' | 11/32" Vacuum Hose |
| 4 | 5/16"-18 x 1-1/2" Grade 8 Hex Head Bolts |
| 4 | 5/16" SAE Flatwasher |
| 4 | 5/16"-18 Flanged Hex Nuts |
| 1 | Posi Lock Fuse Holder w/ 15amp Fuse |
| 1 | 22ga Non-Insulated Ring Terminal, #10 ID |
| 1 | 16ga Non-Insulated Ring Terminal, #10 ID |
| 1 | 16ga Non-Insulated Ring Terminal, 3/8" ID |
| 2 | #10 x .750" Hex Head Drill Screws |
| 1 | 22ga Non-Insulated Wire Splice |
| 1 | 16ga Non-Insulated Wire Splice |
| 4 | 1/4" x 1 1/4" Heat Shrink Tubing |

Pump Installation:

- Find a suitable location to mount the pump. Use the template located on Page 5 of the instructions to find aid in finding a suitable mounting location along with locating the bracket mounting holes. **IMPORTANT:** The pump must be mounted vertical. Mounting the pump horizontally will cause the pump to not operate properly.
- If desired, the vacuum pump orientation within the mounting can be rotated so the vacuum hose exits on the opposite side. To do so, remove the M6-1.0 x 55mm Hex Head Bolts and Nuts holding the pump to the bracket and the 1/4"-20 x .750" Hex Head Bolts holding the module to the bracket. It is not necessary to remove the hose elbow. Within the bracket, rotate the pump and module and re-install the mounting hardware.
- Mount the bracket using the provided 5/16"-18 x 1-1/2" Grade 8 Hex Head Bolts along with the 5/16" SAE Flatwasher and 5/16"-18 Flanged Hex Nuts. Torque the bolts to 25 ft/lbs.

*****IMPORTANT – MUST READ*****

As with any electrical component or system, proper grounding of the installed components is not just recommended but necessary. In addition, the ground system in the vehicle is also very important to the proper operation of this vacuum pump system.

Electrical Installation:

Primary Power Harness

The primary power harness consists of a 16ga red wire and a 16ga black wire terminated with a Weatherpack Connector

- Route the 16ga red power wire to a constant 12 volt power source. We recommend direct to the battery. Secure it by crimping the provided 16ga ring terminal with the 3/8" ID to the wire and covering the crimp with a piece of the provided 1/4" x 1 1/4" Heat shrink tubing.
- Within 12 inches of the battery, cut the wire and install the Posi- Lock Fuse. **NOTE:** See Figure 1 on the next page for instructions on how to install the Posi Lock Fuse Holder.
- Route the 16ga black ground wire to a proper chassis grounding location. Secure it by crimping the provided 16ga ring terminal with the #10 ID to the wire. Cover the crimp with a piece of the provided 1/4" x 1 1/4" Heat shrink tubing. If required, a #10 x .750" Hex Head Drill Screw is included to attach the ring terminal to the chassis.

Step 1
Strip Wire ½"



Step 2
Insert Stripped Wire
into Threaded Ends

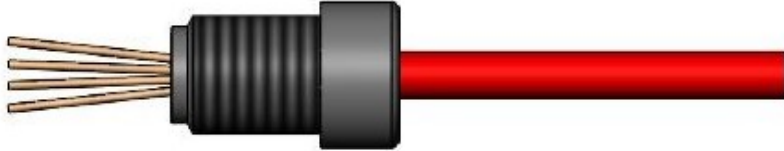

Step 3
Insert Wire and
Threaded Ends into
Fuse Holder and
Tighten

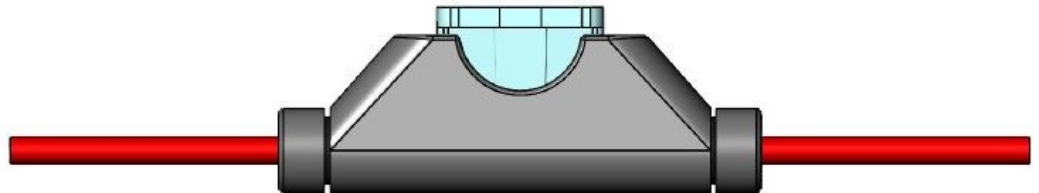

Figure 1 – Posi-Lock Fuse Holder Installation

Switched Power Harness

The switched power harness consists 22ga yellow wire and a 22ga black wire terminated with a waterproof JST connector

- Route the 22ga yellow power wire to a suitable switched 12 volt source. Provided is both a 22ga and a 16ga non-insulated splice that can be used depending on the wire size being spliced into. After splicing and crimping, seal with a piece of the provided 1/4" x 1 1/4" Heat Shrink Tubing.
- Route the 22ga black ground wire to a proper chassis grounding location. Secure it by crimping the provided 22ga ring terminal with the #10 ID to the wire. Cover the crimp with a piece of the provided 1/4" x 1 1/4" Heat shrink tubing. If required, a #10 x .750" Hex Head Drill Screw is included to attach the ring terminal to the chassis.

NOTE: For further electrical wiring information, refer to Figure 2 on the next page for a complete wiring diagram of the entire Electric Vacuum Pump Kit.

Vacuum Pump Wiring Diagram

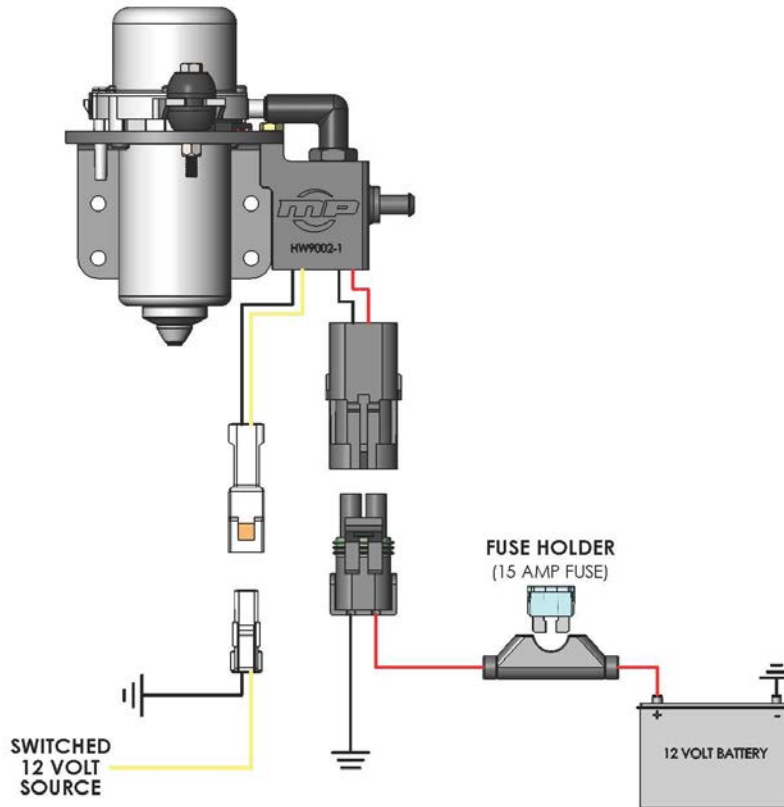

Figure 2 – Wiring Diagram

Vacuum Hose:

- Run the vacuum hose from the machined hose barb on the pump module to the brake booster. Use the provided hose with the kit for installation. If additional hose is needed, either call Master Power or you can pick the hose up locally. **IMPORTANT:** If obtaining additional hose locally, be sure to pick up 11/32" Vacuum Hose. Anything else is unacceptable.

Troubleshooting:

| Fault | Possible Cause | Solution |
|----------------------------|--|---|
| Pump will not turn on | Blown fuse | Replace fuse |
| | Module not grounded properly on either Primary or Switched Harness | Check wiring & ground |
| | No power to pump | Check connector between pump and module |
| | Internal relay failure | Return to MPB for replacement |
| Vacuum pump won't turn off | Vacuum leak in system | Diagnose location of leak and repair |
| | Internal switch failure | Return to MPB for replacement |

MASTER POWER BRAKES VACUUM PUMP / BRACKET MOUNTING TEMPLATE

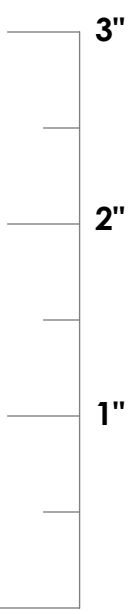
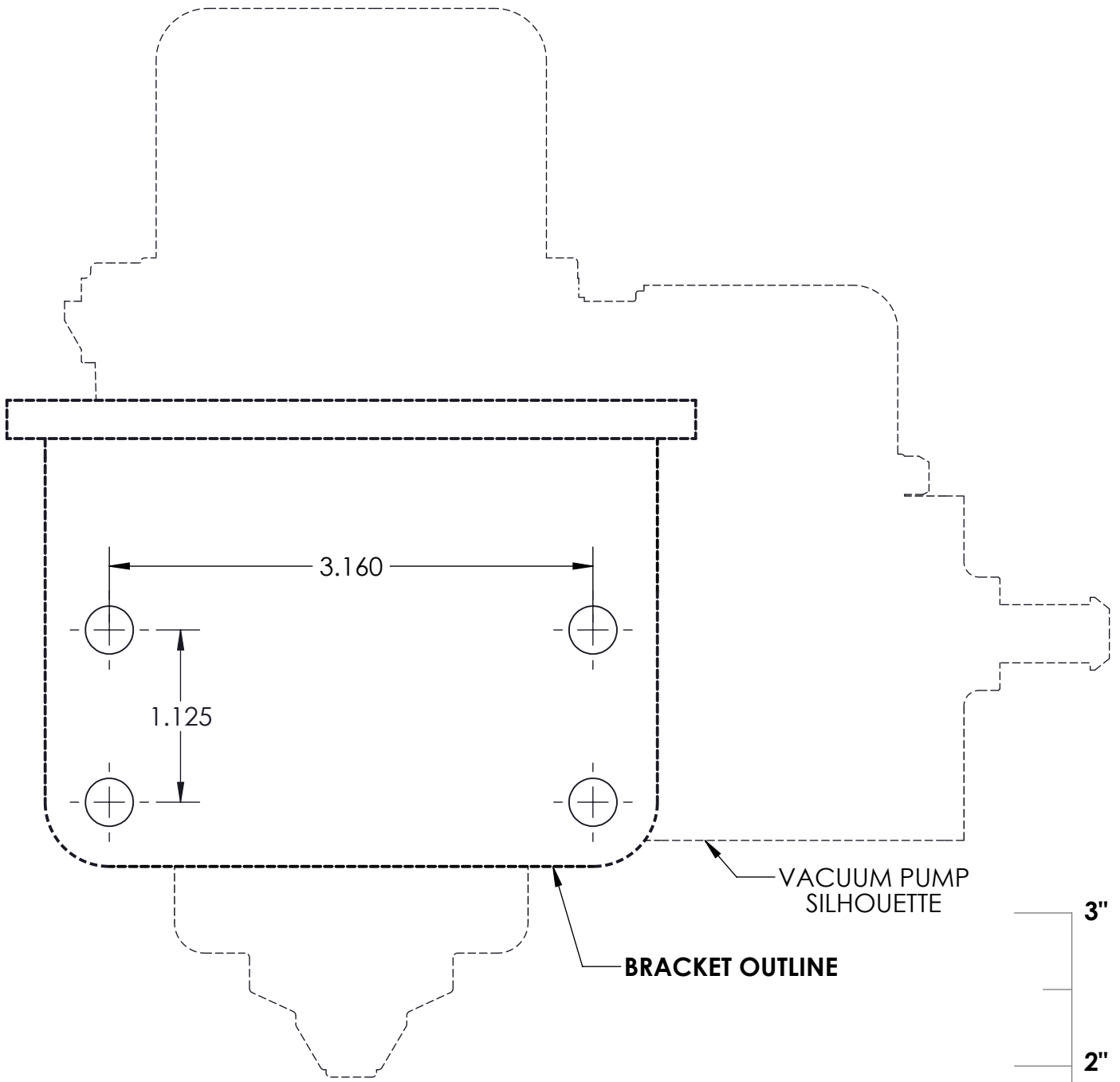

Use provided ruler to verify template has printed to scale



MPB-F400-13