



#20151 Power Steering Bracket Installation Chevy Big Block Long Water Pump

Parts List

- 1-(20151-A) Power Steering Bracket
- 2-(TP3-1.980) Spacer
- 2-(S275) 3/8-16 x 4.25" SHCS
- 1-(S268) 3/8-16 x 3 1/4" SHCS
- 2-(S311) 3/8-16 x 3/4" HHCS
- 2-(S312) 3/8-16 x 1" HHCS
- 6-(S664) 3/8 x 1 x .080 spacer washers
- 1-(20176-A) Front Support Bracket
- 1-(20176-B) Rear Support Bracket

S.H.C.S. = Socket Head Cap Screw
 H.H.S. = Hex Head Screw
 S.S. = Stainless Steel

Use 39.5" 5 rib serpentine belt for serpentine conversions

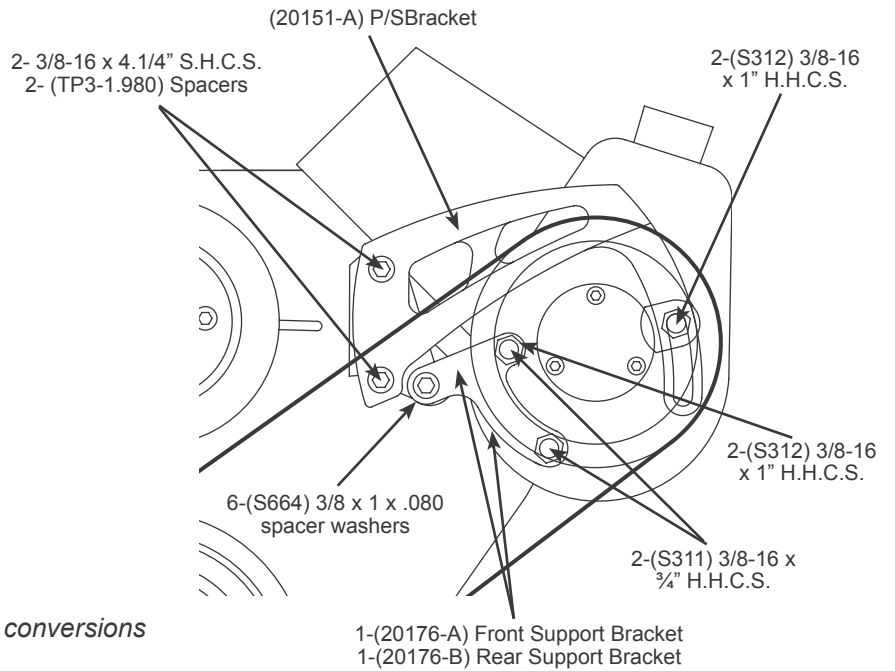

Assembly Instructions (photos show Chevy small block kit but assembly is the same for big block)

1. Mount the (20151-A) Power Steering Bracket & water pump to engine block using two (S275) 3/8-16 x 4.1/4" SHCS & two (TP3-1.980) spacers (between (20151-A) Power Steering Bracket & water pump) (fig. 1).
2. If your power steering pump came equipped with a mounting stud at the rear of the pump, use an 11/16" wrench to remove the mounting stud from the pump unit (fig. 2).

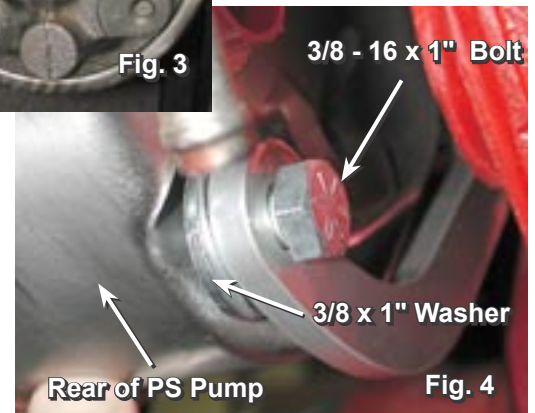
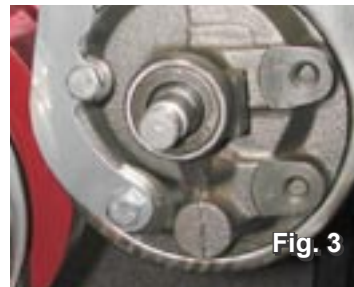

3. Mount the (20176-A) Front Support Bracket to the power steering pump using two (S311) 3/8-16 x 3/4" HHCS (fig. 3).
4. Mount the (20176-B) Rear Support Bracket to the power steering pump using one (S312) 3/8-16 x 1" HHCS & two (S664) 3/8 x 1" x .080 spacer washers. (fig. 4) Do not tighten at this time. (Note; due to variations of water pump boss castings, additional spacer washers may be needed.)

5. Mount (20176-A & B) Support Brackets and P/S pump to water pump boss using one (S268) 3/8-16 x 3 1/4" SHCS. Leave loose enough for adjustment. Now tighten the (20176-B) Rear Support Bracket to the power steering pump.
6. Referring to (fig. 5), the power steering mounting face should meet the back of (20151-A) Power Steering Bracket. If not, use spacer washers in the appropriate places (fig. 4, fig. 6) to properly align pump.

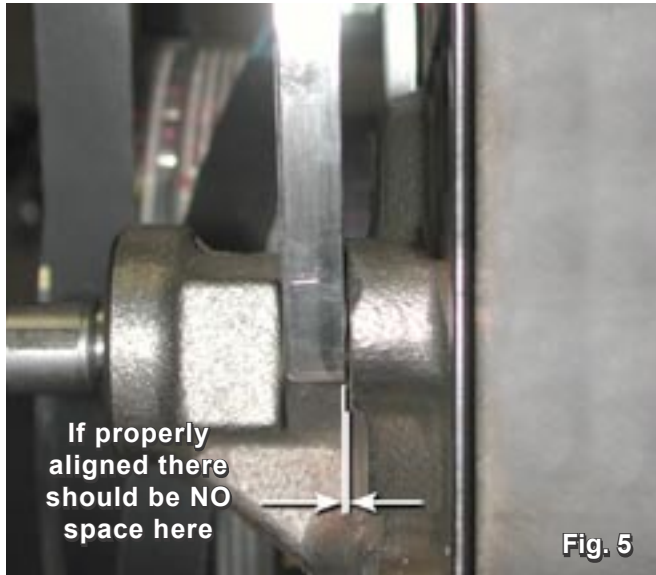

Important Note: Due to variations of water pump boss castings particularly in aftermarket and polished pumps it may be necessary to add spacer washers between (20176-A) Front Support Bracket and the water pump boss. (fig. 6) if this should be required it will also be necessary to place a second spacer washer between the (20176-B) Rear Support Bracket and power steering pump. (fig. 4)

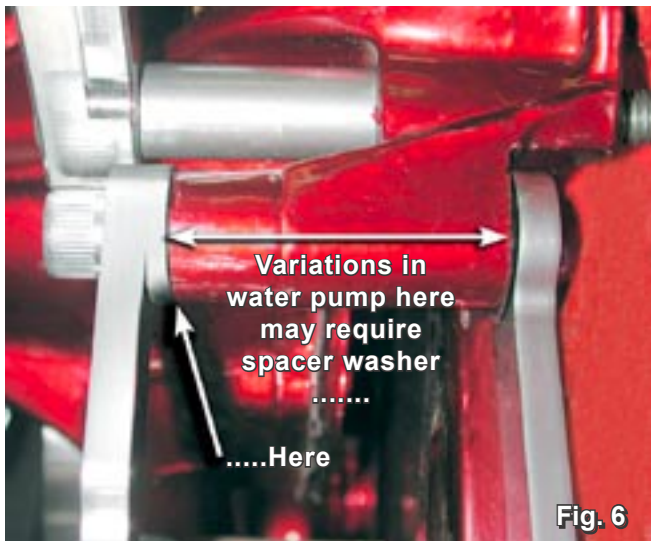

7. Mount (20151-A) Power Steering Bracket to power steering pump using one (S312) 3/8-16 x 1" HHCS & one (S664) washer. (fig. 7) Leave loose for adjustment.

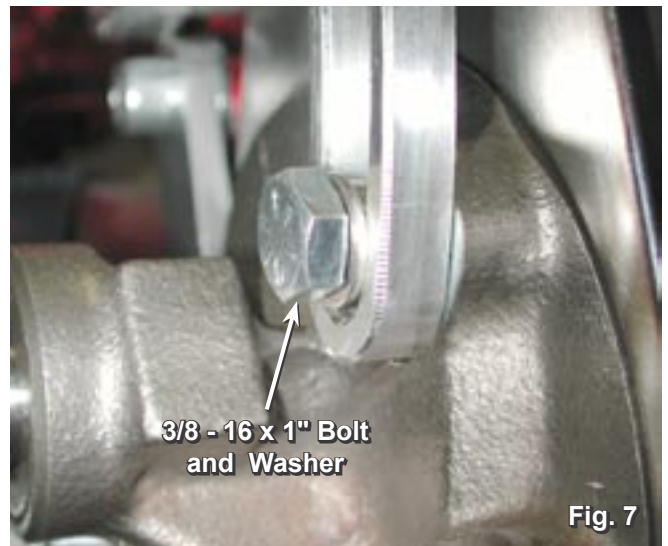

8. Mount power steering pulley to power steering pump shaft. Check power steering pulley to crank pulley alignment. Install belt (Use 39.5" 5 rib serpentine belt for serpentine conversions) and adjust belt tension by pulling up on the power steering pump. Belt tension is correct when there is no more than 1/4" play in the belt at midpoint between the power steering pulley & the crank pulley. Lock the belt tension by tightening the adjustment bolt with a 9/16" opened end wrench (fig. 8).

Tighten (S268) 3/8-16 x 3 1/4" SHCS (step 5) & (S311) 3/8-16 x 3/4" HHCS (step 7).

