



#20112

Adjustable Saginaw Power Steering Bracket Installation Chevy Small Block

Works with MARCH Bracket #: 20132 Outward Mount Alt. Bracket-Passenger Side, 20721 InwardMount Alt. Bracket, 21001 Inward Mount Alt. Bracket

Will not work with MARCH Bracket # 20131 Outward Mount Alt. Bracket

Parts List

- 1-(20112-A) Bracket
- 1-(20112-B) Ear
- 1-(20112-C) Arm
- 1-(RA-2.500) S.S. Adjusting Rod Assy.
- 2-(S248) 3/8-16 x 1.0 S.H.C.S. (mount rod to C Arm)
(mount rod to A bracket)
- 2-(S312) 3/8-16 x 1.0 Hex H.S.(mount C arm to pump 2x)
(mount B ear to pump 2x)
- 2-(S311) 3/8-16 x .75 H.H.S.
- 2-(ORDER) 3/8-16 x 1.75 H.H.S.
(mount A bracket to B ear-use lock washers)
- 2-(ORDER) 3/8 I.D. lock washers.
(mount A bracket to B ear)
- 2-(S256) 3/8-16 x 2 S.H.C.S.
(mount A bracket to engine block)
- 1-A3-200 Spacer

For use with :

- 1-(523) Power Steering Pulley
- 1-(5091) Crank Pulley (performance)
- 1-(15360) 36" V-belt

or:

- 1-(523) Power Steering Pulley
- 1-(6151) Crank Pulley (high water flow)
- 1-(15385) 38 1/2" v-belt

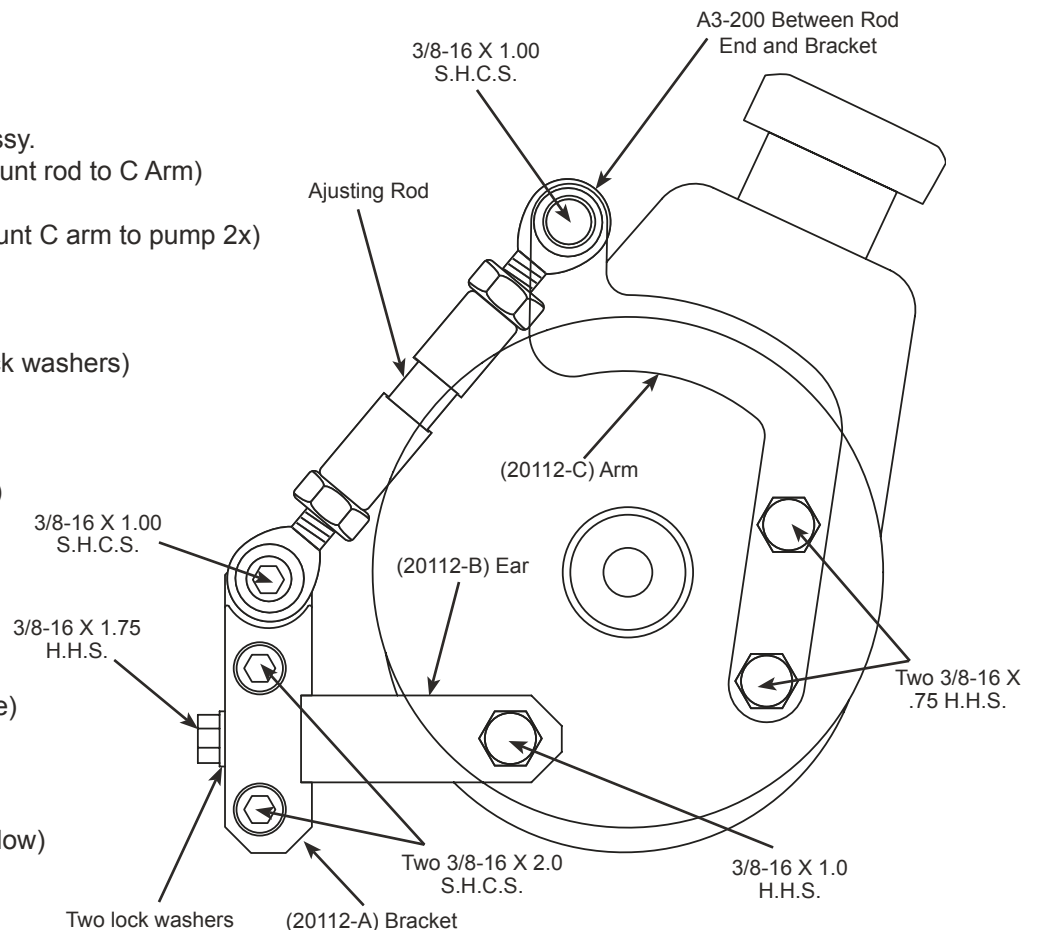

S.H.C.S. = Socket Head Cap Screw
H.H.S. = Hex Head Screw
S.S. = Stainless Steel

Assembly Instructions

1. Bolt (20112-C) Arm to power steering pump using two 3/8-16 X .75 H.H.S.
2. Bolt (20112-B) Ear to power steering pump using two (S312) 3/8-16 X 1.0 H.H.S. from front and back of power steering pump (leave loose to swivel)
3. Bolt (RA-2.500) S.S. Rod Assembly end to (20112-C) Arm using A3-200 spacer and (S248) 3/8-16 X 1.0 S.H.C.S. from back
4. Bolt (20112-B) Ear to (20112-A) Bracket using two (S321) 3/8-16 X 1.75 H.H.S. & two lock washers (leave loose to adjust)
5. Bolt (20112-A) Bracket to engine block using two (S256) 3/8-16 X 2.0 S.H.C.S.
6. Bolt (523) Power Steering Pully to power steering pump
7. Allign (523) Power Steering Pully to Crank Pulley using a straight-edge & tape measure
8. Tighten (20112-B) Ear to (20112-A) Bracket after alligning
9. Install Belt
10. Bolt other end of (RA-2.500) SS Rod Assembly to (20112-A) Bracket using (S248) 3/8-16 X 1.00 S.H.C.S.
11. Adjust belt tension using (RA-2.500) S.S. Rod Assembly
12. Tighten (20112-B) Ear to power steering pump
13. Tighten (RA-2.500) SS Rod Assembly nuts