



AUTOMOTIVE HEATER INSTALLATION GUIDE FOR 9" HEATERS

- MM-A1090002 (9" Heater 2 - 3" Outlets)**
- MM-A1090004 (9" Heater Grill Face with Mounting Flange)**
- MM-A1090009 (9" Heater Grill Face)**

PREPARATION & MOUNTING

Position the heater and determine clearance and mounting surfaces are adequate. Identify the engine coolant source and return connections, and plan routing of the (2) heater hoses such that they will not be damaged by sharp edges or abrasion. Mark locations to drill for the fasteners using the mounting locations of the heater. Mount the heater.

COOLANT CONNECTIONS

The vehicle cooling system should be cool and drained, prior to heater installation. 9" heaters have no bias in hose connection. 16" heaters have one tube marked 'inlet', this tube must be connected to the coolant source and not the return. Connecting the heater inlet to the return line will reduce heat output as much as 25%. Plan routing of the wiring and 5/8" heater hoses so they will not be damaged by sharp edges or abrasion. After the vehicle has come to operating temperature the first time with heater installed and valve open, the cooling system will need to be 'topped up' as air trapped during the installation will have escaped.

ELECTRICAL CONNECTIONS

The heater electrical circuit must be fused for safety, with the fuse placed as near the vehicle electrical connection as possible. The recommended fuse is 15 amp. The heaters have a separate ground (-) wire that must be utilized to complete the electrical circuit. 16 gage is the correct wire for all connections. A 5' harness is provided to connect the switch to the heater.

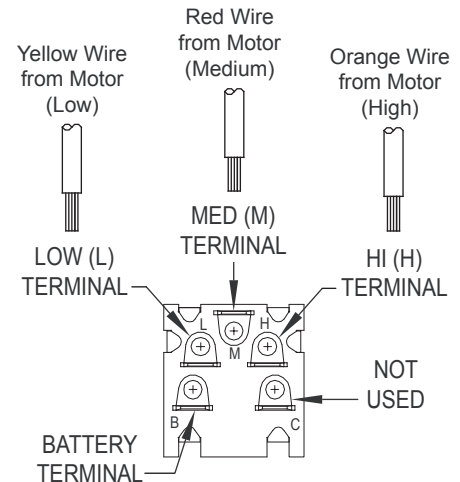

Learn more about replacement A/C and heating parts we have.