

MFA110 - ADJUSTABLE THERMOSTAT SWITCH

Assembly instructions:

1. Attach the thermostat to the mounting bracket using the two machine screws provided in the hardware kit (see Figure 1).
2. Using the 3 mounting screws provided, mount the thermostat to any flat surface in the engine compartment (provided it is within 18" of the radiator inlet hose). A star washer is included for a ground wire connection.
3. Insert the remote sensing bulb into the radiator fins as close to the inlet hose as possible. For consistent operation the bulb should not be placed in an area of high air flow. The installer may make a pilot hole through the radiator fins using a #1 screwdriver; however care must be taken to avoid damaging the radiator tubes.

Note: MFA110 thermostat kit does not include a knob for turning the control shaft. Maradyne recommends using the thermostat without a knob to help insure that the thermostat is not accidentally adjusted to the wrong temperature once set.

Adjustable Thermostat Switch Includes:

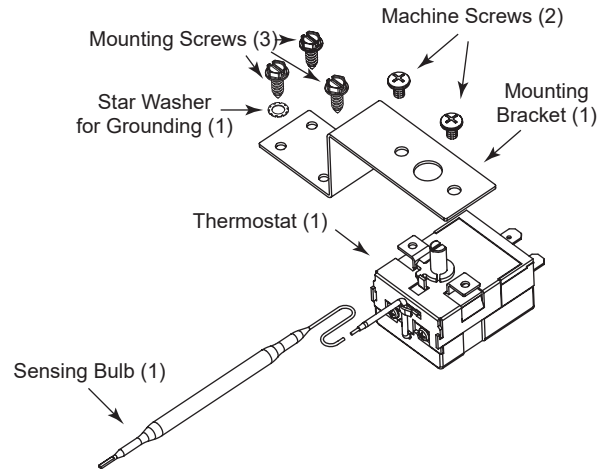

Figure 1 – Kit Contents

Wiring instructions:

The MFA110 thermostat may be used to switch either the positive or negative connection. **Figure 2** shows the thermostat directly controlling a fan which is only valid for fans drawing less than 10 amps. For fans drawing more than 10 amps, a relay harness such as the Maradyne MFA100 Fan Relay Harness must be used.

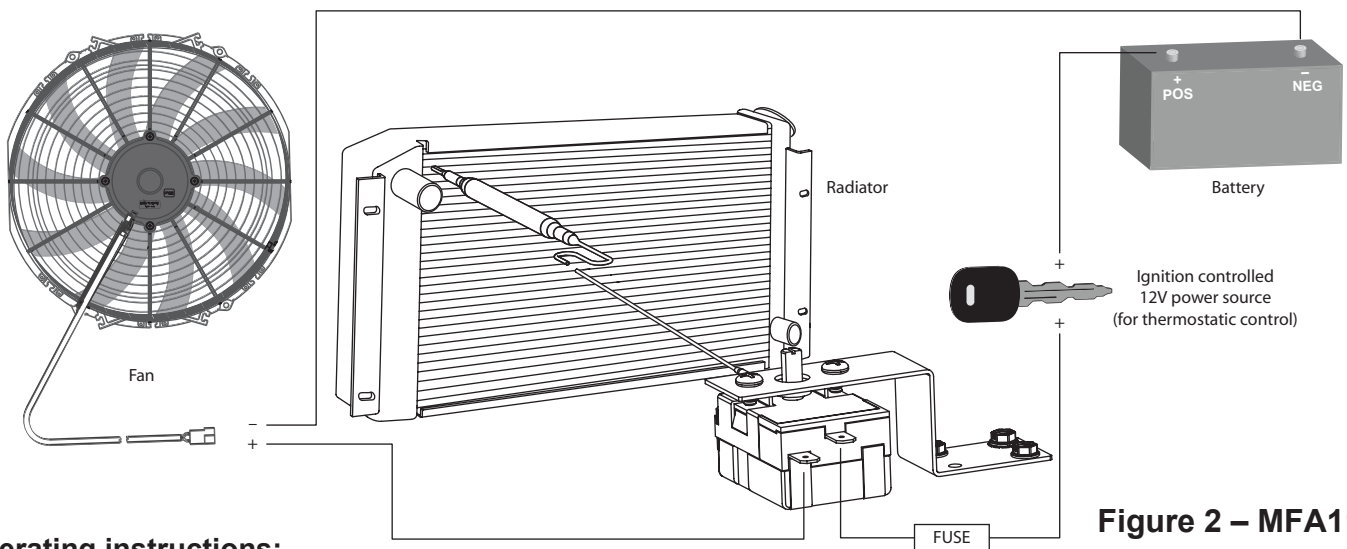

Figure 2 – MFA110

Operating instructions:

The thermostat may be adjusted to engage at any temperature between 32°F and 248°F. Once engaged, the switch will disengage once the bulb senses approximately 20°F degrees cooler. To set the engagement temperature, make sure the engine is completely cool. Turn the thermostat shaft all the way clockwise till it stops. Start the engine and let it warm to the desired temperature for fan activation. Once the desired engine temperature is achieved, turn the shaft counter clockwise until the fan turns on. The temperature is now set and fan will stay on until temperature cools approximately 20°F degrees.