

1997-2004 CHEVY CORVETTE C5 5.7L V8 LS-1, LS-6 (AXLE-BACK)

Warning: When working on, under, or around any vehicle exercise caution. Please allow the vehicle's exhaust system to cool before removal, as exhaust system temperatures may cause severe burns. If working without a lift, always consult vehicle manual for correct lifting specifications. Always wear safety glasses and ensure a safe work area. Serious injury or death could occur if safety measures are not followed.

Step 1: (Carefully read all instructions before installation) Disconnect the vehicle's battery before removal of the OEM exhaust. This will allow the computer to reset itself with the new system, and prevent electrical accidents. Begin removal of the OEM system by removing the 4 swaybar mounting bolts at the rear of the transmission. Do not discard these fasteners, as you will need them to re-mount the swaybar. Unbolt the mufflers from the catalytic converter extension pipes at the 2-bolt flanges. Remove the mufflers from the OEM rubber insulators (Removal of the passenger-side heat shield will aid in the extraction of the muffler.) Do not damage the OEM rubber insulators, as they will be re-used to mount the new system.

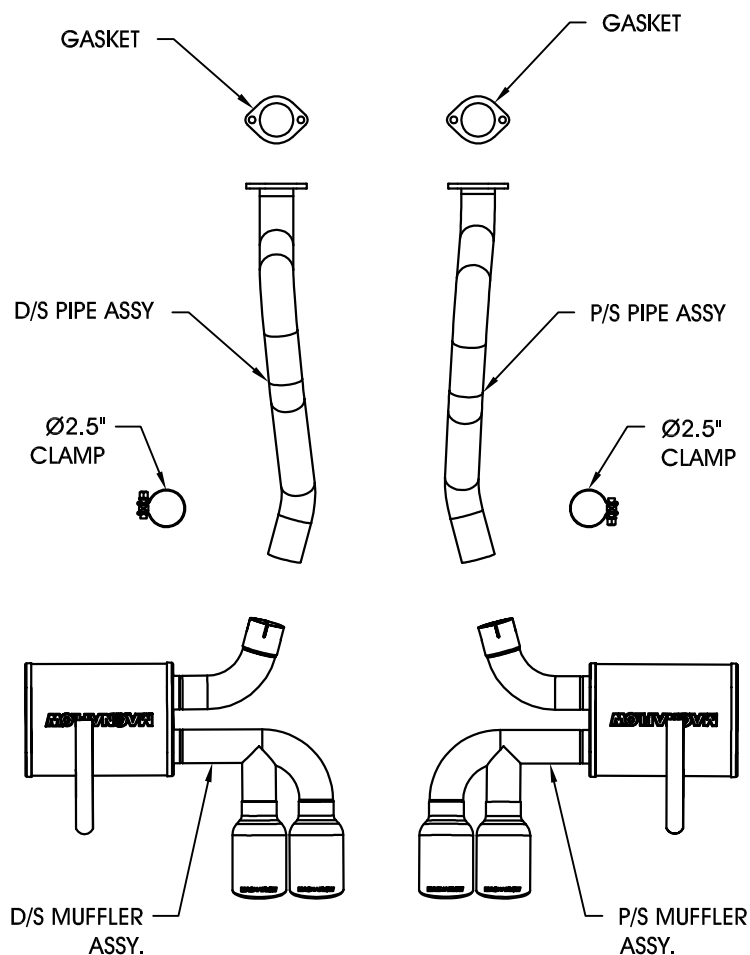

Step 2: Begin installation by fitting the new driver's and passenger's side mufflers assemblies into the OEM rubber insulators. Leave all fasteners and clamps loose for the final adjustment of the complete exhaust system. Using a provided 2.5" clamp, install the driver's side pipe assembly and fastened it at the 2-bolt flange location to the OEM H-pipe using the supplied gaskets and OEM fasteners. Install the passenger's pipe assembly in a similar fashion.

Step 3: With all components mounted loosely, adjust the system for overall aesthetics and clearance of frame & bodywork. (MAGNAFLOW recommends at least 1/2" of clearance between the exhaust system and any body panels to prevent heat-related body damage or fire.)

Step 4: Once a final position has been chosen for the new system, evenly tighten all fasteners from front to rear. Re-install the rear swaybar mounts using the OEM fasteners. The supplied band clamps must be VERY tight to properly align the pipes and prevent leaks (Approximately 65ft-lbs). U-bolt clamps should be tightened to approximately 30-35ft-lbs. Inspect all fasteners after 25-50 miles of operation and retighten if necessary.

*MAGNAFLOW Performance Exhaust recommends professional installation on all their products