

2005- CHRYSLER / DODGE / SRT 6.1L, HEMI V8

Warning: When working on under or around any vehicle exercise caution. Please allow the vehicle's exhaust system to cool before removal, as exhaust system temperatures may cause severe burns. If working without a lift, always consult vehicle manual for correct lifting specifications. Always wear safety glasses and ensure safe work area. Serious injury or death could occur if safety measures are not followed.

Step 1: (Carefully read all instructions before installation) Disconnect the vehicle's battery before removal of the OEM exhaust system. This will allow the computer to reset itself with the new exhaust system and prevent electrical accident. To begin removal of the OEM system, unbolt the driver's side muffler assembly where the assembly connects with the center muffler / resonator. The driver's muffler assembly can now be removed by disengaging the welded hangers from the OEM rubber insulators. Do not damage the OEM rubber insulators, as they will be re-used to mount the new exhaust system. Loosen the OEM clamps from where the system connects to catalytic converter extensions. The remaining exhaust system can now be removed by disengaging the welded hangers from the OEM rubber insulators.

Step 2: Begin installation of the new system by fastening the (2) Inlet pipes to the catalytic converter extensions using the supplied 2.75" clamps. Leave all clamps and fasteners loose for final adjustment of the complete system. Install the mid muffler assembly using the supplied 3.00" clamps and by fitting the welded hangers into the OEM rubber insulators. Install the driver's and passenger's muffler assemblies in a similar fashion.

Step 3: With all components mounted loosely, adjust the system for overall aesthetics and clearance of frame & bodywork. (MAGNAFLOW recommends at least 1/2" of clearance between the exhaust system and any body panels to prevent heat-related body damage or fire.)

Step 4: Once a final position has been chosen for the new system, evenly tighten all fasteners from front to rear. The supplied band clamps must be VERY tight to properly align the pipes and prevent leaks (approximately 65ft-lbs). U-bolt clamps should be tightened to approximately 30 - 35ft-lbs. Inspect all fasteners after 25-50 miles of operation and retighten if necessary.

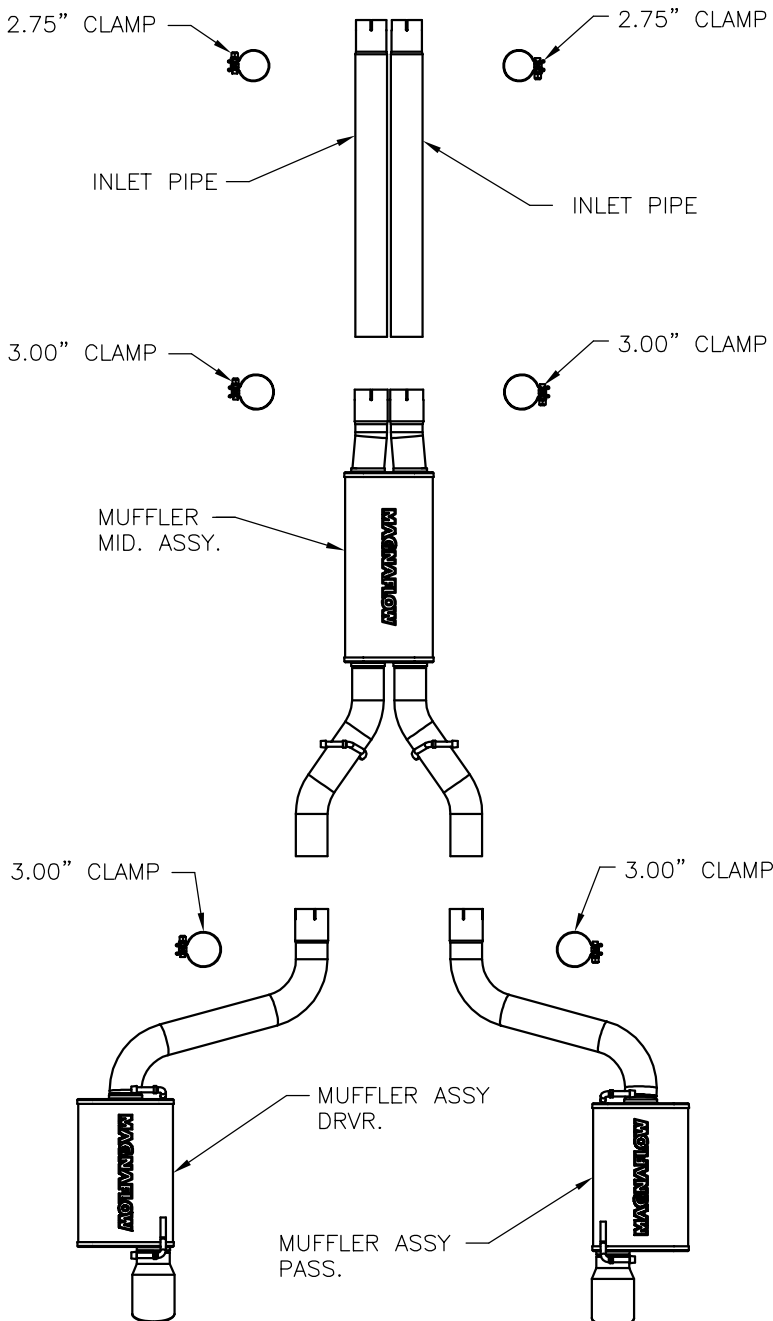

*MAGNAFLOW Performance Exhaust recommends professional installation on all their products