

2001- BMW M3 E46 3.2L I-6

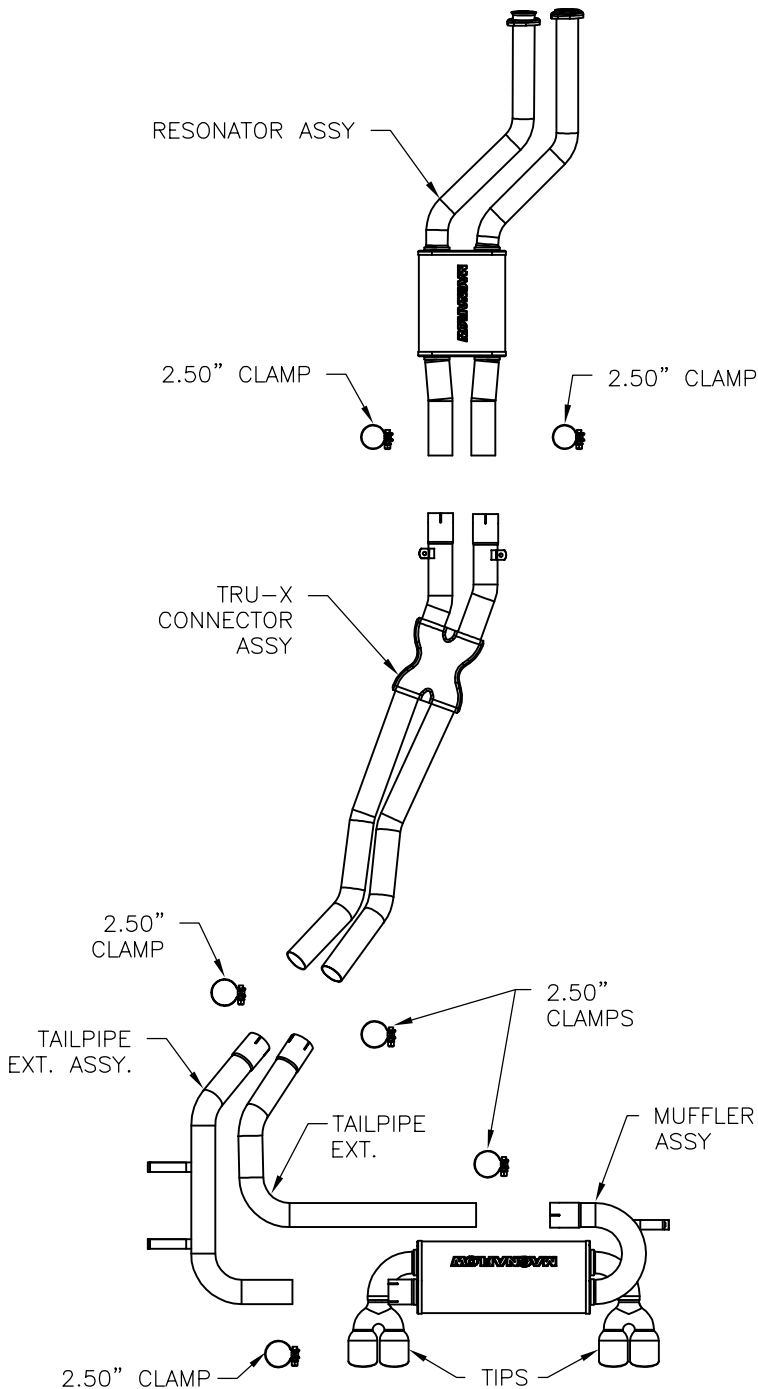

Warning: When working on, under, or around any vehicle exercise caution. Please allow the vehicle's exhaust system to cool before removal, as exhaust system temperatures may cause severe burns. If working without a lift, always consult vehicle manual for correct lifting specifications. Always wear safety glasses and ensure a safe work area. Serious injury or death could occur if safety measures are not followed.

Step 1: (Carefully read all instructions before installation)

Disconnect the vehicle's battery before removal of the OEM exhaust system. This will allow the computer to reset itself with the new system, and prevent electrical accidents. Begin removal of OEM exhaust system by removing the OEM fasteners located at the 2-bolt flanges. Do not discard the OEM fasteners, as they will be reused to mount the new system. Remove all of the remaining fasteners from the mounting brackets and crossbraces that connect or mount the system, then remove the exhaust assemblies. Remove the muffler assembly by unbolting the hanger brackets from the frame. Take note of the positions of each bracket for reinstallation with the new muffler and pipes.

Step 2: Working in a front to rear fashion, install the new resonator assembly by reusing the OEM fasteners. Leave all fasteners loose for final adjustment of the complete system. Using two of the supplied 2.50" clamps, install the Tru-X crossover assembly. Install the remaining components as shown in a similar fashion using the supplied clamps and OEM fasteners. When installing the muffler assembly, install the OEM hanger brackets on the new muffler and muffler inlet pipe, then install the muffler on the vehicle.



INSTALLATION INSTRUCTIONS FOR 16602

2001- BMW M3 E46 3.2L I-6

***Warning:** When working on, under, or around any vehicle exercise caution. Please allow the vehicle's exhaust system to cool before removal, as exhaust system temperatures may cause severe burns. If working without a lift, always consult vehicle manual for correct lifting specifications. Always wear safety glasses and ensure a safe work area. Serious injury or death could occur if safety measures are not followed.*

Step 3: With all components mounted loosely, adjust the system for overall aesthetics and clearance of frame & bodywork. (MAGNAFLOW recommends at least 1/2" of clearance between the exhaust system and any body panels to prevent heat-related body damage or fire.)

Step 4: Once a final position has been chosen for the new system, evenly tighten all fasteners from front to rear. The supplied band clamps must be VERY tight to properly align the pipes and prevent leaks (Approximately 65ft-lbs). Inspect all fasteners after 25-50 miles of operation and retighten if necessary.

**MAGNAFLOW Performance Exhaust recommends professional installation on all their products*