

2004- DODGE RAM SRT-10 - V10 8.3L, STANDARD. CAB SHORT BED

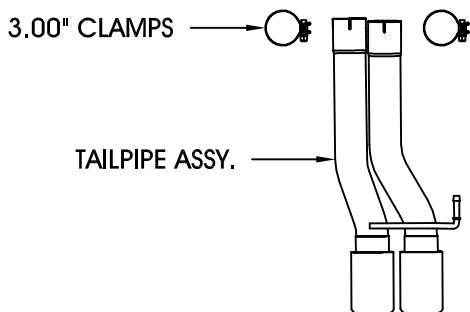
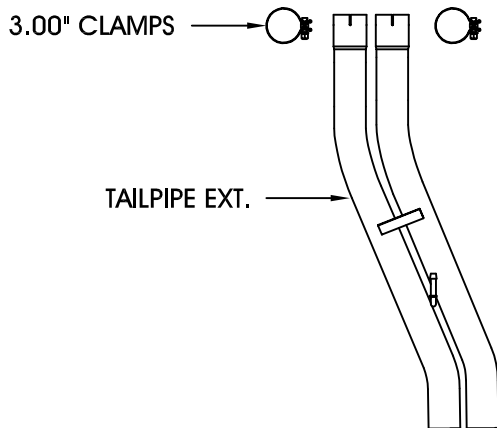
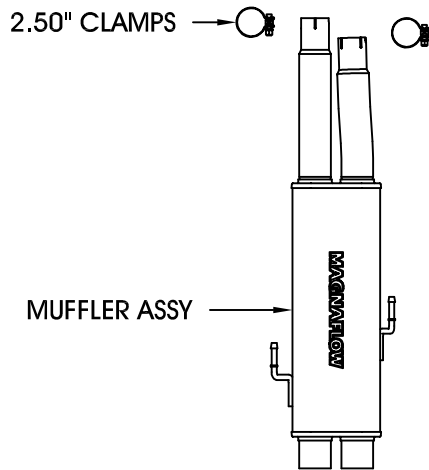

**Warning:** When working on, under, or around any vehicle exercise caution. Please allow the vehicle's exhaust system to cool before removal, as exhaust system temperatures may cause severe burns. If working without a lift, always consult vehicle manual for correct lifting specifications. Always wear safety glasses and ensure a safe work area. Serious injury or death could occur if safety measures are not followed.

**Step 1:** (Carefully read all instructions before installation) Disconnect the vehicle's battery before removal of the OEM exhaust. This will allow the computer to reset itself with the new system, and prevent electrical accidents. To remove the OEM system, first unbolt the clamps fastening the muffler to the catalytic converters. Unbolt the remaining clamps on the tailpipe, then disengage the welded hangers from the OEM rubber insulators and extract the system from the vehicle.

**Step 2:** Install the new muffler assembly by fitting the welded hangers into the OEM rubber insulators, and by fastening the inlet pipes to the catalytic converter pipes using the supplied 2.50" clamps. Install the tailpipe extension, and tailpipe assembly in the same fashion using the supplied 3.00" clamps.

**Step 3:** With all components mounted loosely, adjust the system for overall aesthetics and clearance of frame & bodywork. (MAGNAFLOW recommends at least 1/2" of clearance between the exhaust system and any body panels to prevent heat-related body damage or fire.)

**Step 4:** Once a final position has been chosen for the new system, evenly tighten all fasteners from front to rear. The supplied band clamps must be VERY tight to properly align the pipes and prevent leaks (Approximately 65 ft-lbs). Inspect all fasteners after 25-50 miles of operation and retighten if necessary.

\*MAGNAFLOW Performance Exhaust recommends professional installation on all their products