

VOLKSWAGEN BEETLE / GOLF / JETTA

*15648 IS SHOWN, OTHER SYSTEMS MAY VARY SLIGHTLY IN APPEARANCE.

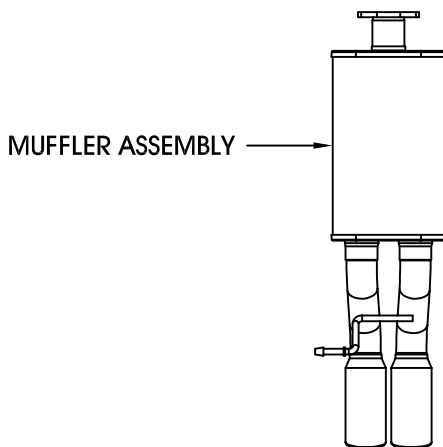
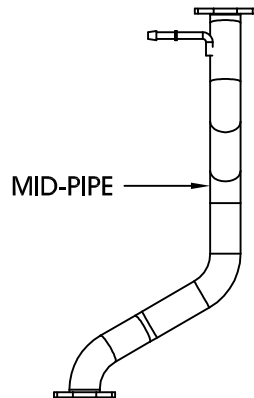
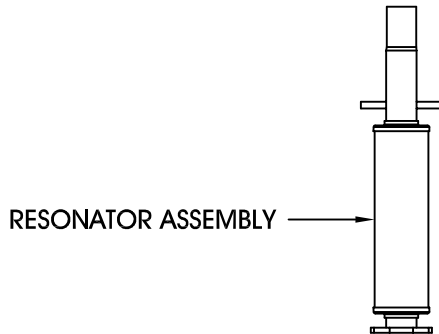

Warning: When working on, under, or around any vehicle exercise caution. Please allow the vehicle's exhaust system to cool before removal, as exhaust system temperatures may cause severe burns. If working without a lift, always consult vehicle manual for correct lifting specifications. Always wear safety glasses and ensure a safe work area. Serious injury or death could occur if safety measures are not followed.

Step 1: (Carefully read all instructions before installation) Disconnect the vehicle's battery before removal of the OEM exhaust. This will allow the computer to reset itself with the new system, and prevent electrical accidents. If the OEM exhaust system is one piece, you will need to cut the tubing between the resonator and the torsion beam to remove the system from the vehicle. The tunnel crossmember will also need to be removed. Do not damage or discard the OEM fasteners or rubber insulators as they be reuse to mount the new system.

Step 2: Install the new resonator assembly by fastening it to the catalytic converter using the OEM clamp. Leave all clamps and fasteners loose for final adjustment of the complete system. Install the new mid-pipe using the supplied gasket and fasteners and by fitting the welded hanger into the rubber insulator. Install the new muffler assembly in a similar fashion.

Step 3: With all components mounted loosely, adjust the system for overall aesthetics and clearance of frame & bodywork. (MAGNAFLOW recommends at least 1/2" of clearance between the exhaust system and any body panels to prevent heat-related body damage or fire.)

Step 4: Once a final position has been chosen for the new system, evenly tighten all fasteners from front to rear. The supplied 7/16" fasteners should be tightened to approximately 35-40ft-lbs. Inspect all fasteners after 25-50 miles of operation and retighten if necessary.

*MAGNAFLOW Performance Exhaust recommends professional installation on all their products