

2009 - 2010 Land Rover LR2 3.2L

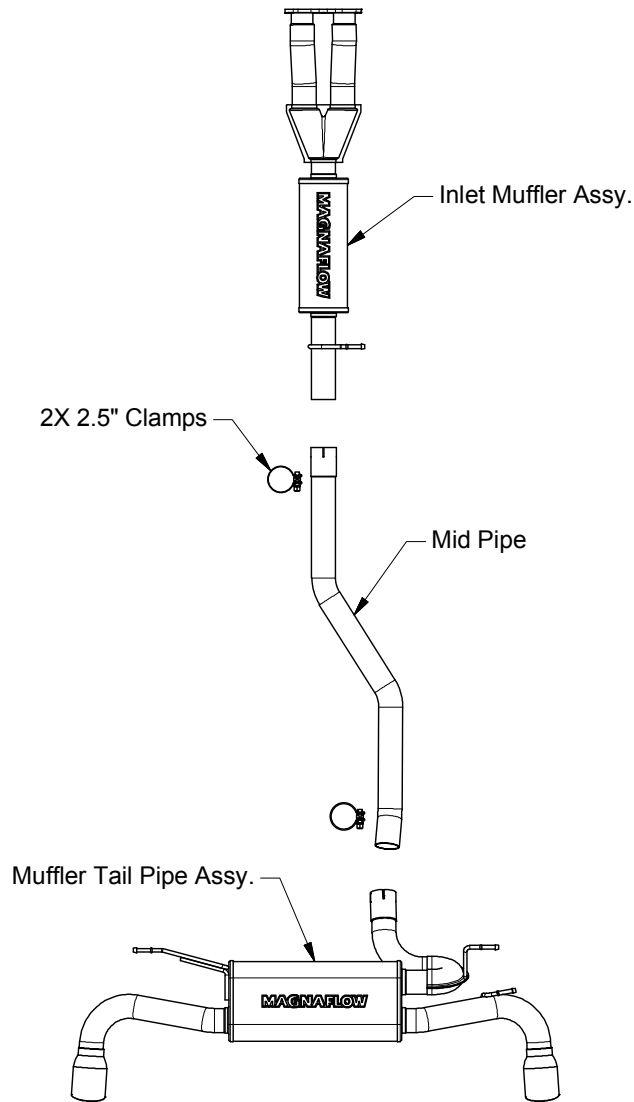

Warning: When working on, under, or around any vehicle exercise caution. Please allow the vehicle's exhaust system to cool before removal, as exhaust system temperatures may cause severe burns. If working without a lift, always consult vehicle manual for correct lifting specifications. Always wear safety glasses and ensure a safe work area. Serious injury or death could occur if safety measures are not followed.

Step 1: (Carefully read all instructions before installation) Remove the OEM system by first unbolting the flange that attaches to the catalytic converter bank. Working front to rear, disengage all welded hangers from the rubber isolators. Be Sure to retain all mounting hardware and rubber as it will be needed to mount your new MAGNAFLOW system.

Step 4: Install your new system by first bolting the inlet flange of the inlet muffler assembly to the catalytic converter bank. Use the OEM hardware to loosely secure. Slip the inlet of the mid pipe over the outlet of the inlet muffler assembly and secure loosely using the supplied clamp. Attach the muffler tail pipe assembly in the same fashion. Locate all welded hangers to the rubber isolators.

Step 2: With all components mounted loosely, adjust the system for overall aesthetics and clearance of frame & bodywork. (MAGNAFLOW recommends at least 1/2" of clearance between the exhaust system and any body panels to prevent heat-related body damage or fire.)

Step 3: Once a final position has been chosen for the new system, evenly tighten all fasteners from front to rear. The supplied band clamps must be VERY tight to properly align the pipes and prevent leaks (Approximately 40ft-lbs). U-bolt clamps should be tightened to approximately 30-35ft-lbs. Inspect all fasteners after 25-50 miles of operation and retighten if necessary.

**** Magnaflow Performance Exhaust recommends professional installation on all their products**