



# INSTALLATION INSTRUCTIONS



NISSAN FRONTIER

PART NO. 19574

## BILL OF MATERIALS:

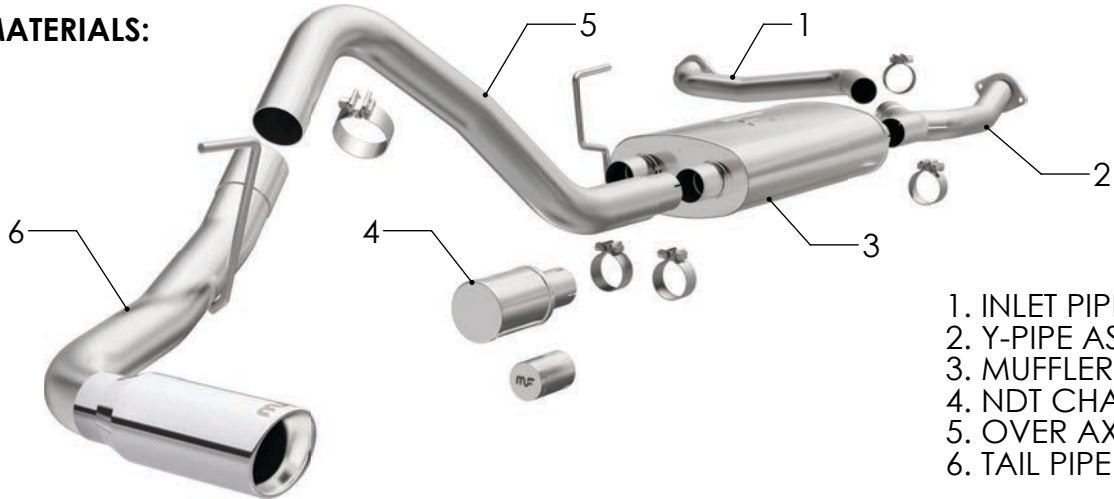

- 1. INLET PIPE
- 2. Y-PIPE ASSY
- 3. MUFFLER ASSY
- 4. NDT CHAMBER
- 5. OVER AXLE PIPE
- 6. TAIL PIPE ASSY



WEAR SAFETY GLASSES



READ INSTRUCTIONS THOROUGHLY BEFORE INSTALLING PRODUCT



SPRAY LUBRICANT

To ease removal of existing exhaust components (especially on older vehicles) spray penetrating lubricant on all fasteners and hangers/insulators that will be loosened or removed and let soak before disassembly.

## HARDWARE KIT:

- 1. [4] 2.50" Clamp
- 2. [1] 3.00" Clamp
- 3. [1] MF Block Off Pipe

## MINIMUM REQUIRED TOOLS:



13,15 mm



Hanger Tool (Or Pry Bar)

## MAGNAFLOW RECOMMENDS PROFESSIONAL INSTALLATION ON ALL THEIR PRODUCTS



**WARNING:** When working on, under, or around any vehicle exercise caution. Please allow the vehicle's exhaust system to cool before removal, as exhaust system temperatures may cause severe burns. If working without a lift always consult vehicle manual for correct lifting specifications. Always wear safety glasses and ensure a safe work area. Serious injury or death could occur if safety measures are not followed.

**ATTENTION:** Always install any supplied band or U-bolt clamps to the proper torque specifications of 40-45 ft-lb for band clamps and 30-35 ft-lb for U-bolt clamps. Over tightening will result in the clamps breaking and will NOT be warranted by MagnaFlow.

## INSTALLATION INSTRUCTIONS



**Step 1.** Remove the OEM system by first unbolting both inlet assemblies from the front catalytic converters.

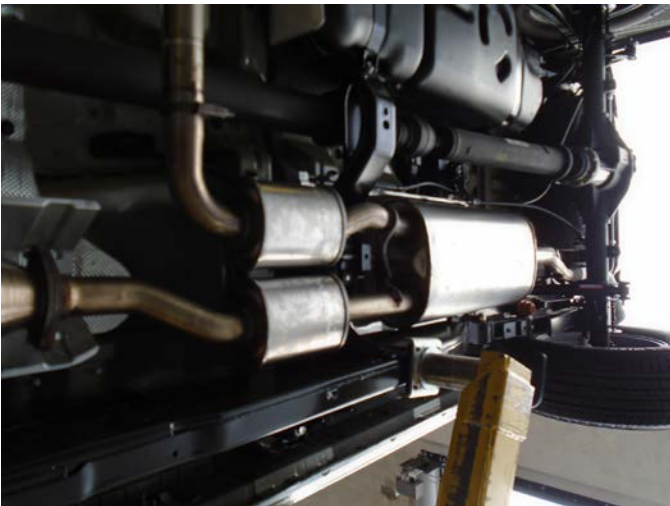

**Step 2.** Next, loosen all factory pipe clamps and disengage the welded hangers from the rubber isolators. Retain all mounting hardware as it will be needed to mount your new MAGNAFLOW system.



**Step 3.** Begin installing your new system by loosely attaching the Inlet Pipe Assembly to the drivers side catalytic converter outlet using the OEM hardware. Loosely slip the inlet of the Y-Pipe Assembly over the Inlet Pipe outlet and loosely secure with the supplied clamp. Loosely secure the Y-Pipe flange to the passengers side catalytic converter using the OEM hardware.



**Step 4.** Install the Muffler Assembly by engaging the welded hangers to the rubber isolators. The system comes with the option of using the NDT chamber or the Block Off Cap for a more aggressive exast note. Loosely attach the Muffler Assembly inlet to the Y-Pipe outlet using the supplied clamp.

## INSTALLATION INSTRUCTIONS



**Step 5.** Loosely install the Over Axle Pipe and Tail Pipe Assembly using the supplied clamps.



**Step 6.** Once a final position has been chosen for the new exhaust system, evenly tighten all clamps from front to rear using the torque specification on page one of these instructions. Inspect all fasteners after 25-50 miles of operation. Re-tighten if necessary.