



INSTALLATION INSTRUCTIONS



FORD F-150

PART NO. 19565

BILL OF MATERIALS:

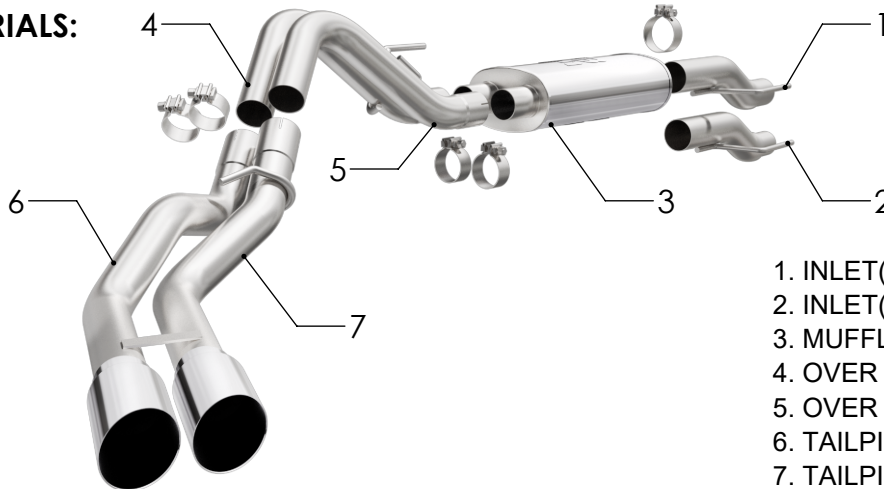

1. INLET(A)2.75 O.D.
2. INLET(B)2.50 O.D.
3. MUFFLER ASSEMBLY
4. OVER AXLE ASSEMBLY D/S
5. OVER AXLE ASSEMBLY P/S
6. TAILPIPE ASSEMBLY D/S
7. TAILPIPE ASSEMBLY P/S



WEAR SAFETY GLASSES



READ INSTRUCTIONS THOROUGHLY BEFORE INSTALLING PRODUCT



SPRAY LUBRICANT

To ease removal of existing exhaust components (especially on older vehicles) spray penetrating lubricant on all fasteners and hangers/insulators that will be loosened or removed and let soak before disassembly.

HARDWARE KIT:

1. [4] 2.50" Clamp
2. [1] 3.00" Clamp
3. [1] Hanger Brkt. Assy. P/S
4. [1] Hanger Brkt. Assy. D/S
5. [2] Rubber Insulator
6. [2] M8x1.25 Bolt Hex
7. [2] M8x1.25 Nut

MINIMUM REQUIRED TOOLS:



15 mm



Hanger Tool (Or Pry Bar)

MAGNAFLOW RECOMMENDS PROFESSIONAL INSTALLATION ON ALL THEIR PRODUCTS



WARNING: When working on, under, or around any vehicle exercise caution. Please allow the vehicle's exhaust system to cool before removal, as exhaust system temperatures may cause severe burns. If working without a lift always consult vehicle manual for correct lifting specifications. Always wear safety glasses and ensure a safe work area. Serious injury or death could occur if safety measures are not followed.

ATTENTION: Always install any supplied band or U-bolt clamps to the proper torque specifications of 40-45 ft-lb for band clamps and 30-35 ft-lb for U-bolt clamps. Over tightening will result in the clamps breaking and will NOT be warranted by MagnaFlow.

INSTALLATION INSTRUCTIONS

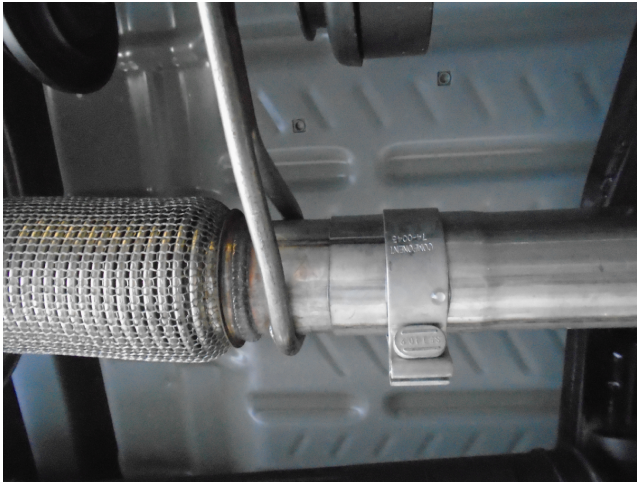

Step 1. To remove the OEM exhaust system, loosen the clamp attaching the systems inlet pipe to the catalytic converter outlet pipe. Disengage all welded hangers from the OEM rubber insulators. Do not discard the OEM fasteners or damage the rubber insulators as they will be needed to mount your new MAGNAFLOW system.

TABLE 1.

INLET	VEHICLE
A	2021 2.7L/3.5L/5.0L
B	2015-2020 2.7L/3.5L/5.0L



Step 2. Begin installing the new system by first using *Table 1.* to determine which Inlet Pipe Assembly to use for your vehicle. Once determined attach the Inlet Pipe Assembly to the OEM catalytic converter outlet pipes using the existing clamp and hardware. Locate the welded hanger to the rubber insulator. Leave all clamps and fasteners loose for final adjustment of the complete system once installed.

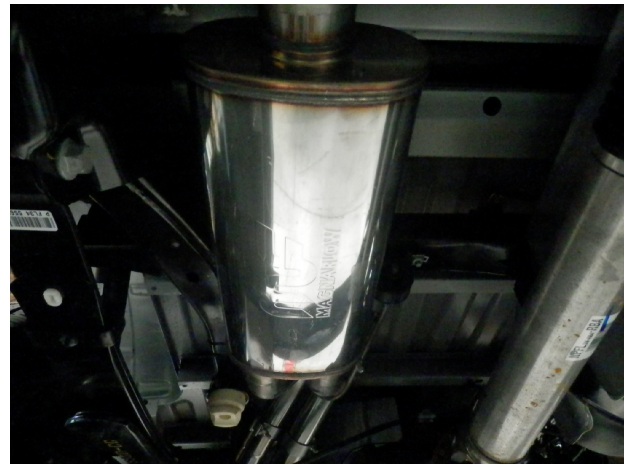

Step 3. Attach the Muffler Assembly to the Inlet Pipe Assembly with a supplied 3.00" clamp, fit the hanger into the rubber insulator.

INSTALLATION INSTRUCTIONS

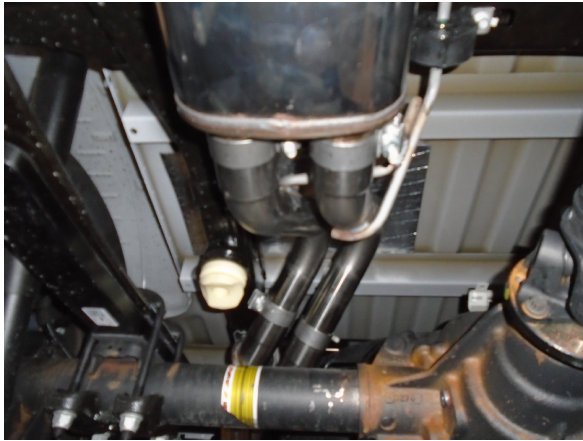

Step 4. Install both the Over Axle Pipes using the supplied 2.50" clamps. Locate the welded hanger to the OEM rubber insulator.



Step 5. Once a final position has been chosen for the new exhaust system, evenly tighten all clamps from front to rear using the torque specifications on page one of the instructions. Inspect all fasteners after 25-50 miles of operation and re-tighten if necessary.